

Natural Refrigerant Training Summit

Building a Sustainable Workforce

**CO2 Climate Study, TCO Study, ESG
and Controls Transition Plan**

Andre Patenaude

Mike Hill

Copeland



NORTH AMERICAN
**Sustainable
Refrigeration
Council**

COPELAND

CO₂ Climate Study – High Ambient Strategies

- Closer look at St Louis and Atlanta

Total Cost of Ownership Study - 8 Ref. Architectures

Copeland ESG Goals and Objectives

Andre Patenaude

Director Solution Strategy, Copeland





Impact of Ambient on CO₂ System Selection



CEO 2 With Confidence

COPELAND

Overview

- **Selected 13 climate zones**
 - **ASHRAE and IECC**
- **Determine cities**
- **Compile ambient bin data**
 - **S.C. & T.C. hours for each**
 - **Dry and adiabatic hours**
- **Identify key strategies**
- **Build energy comparison**
- **Additional technologies**
- **External variables**



Desired Outcome of Study

**To provide a guideline
on comparing high
ambient strategies
for CO₂ transcritical
booster systems for
the Americas**

Climate Zone Categories

California 5 Zones

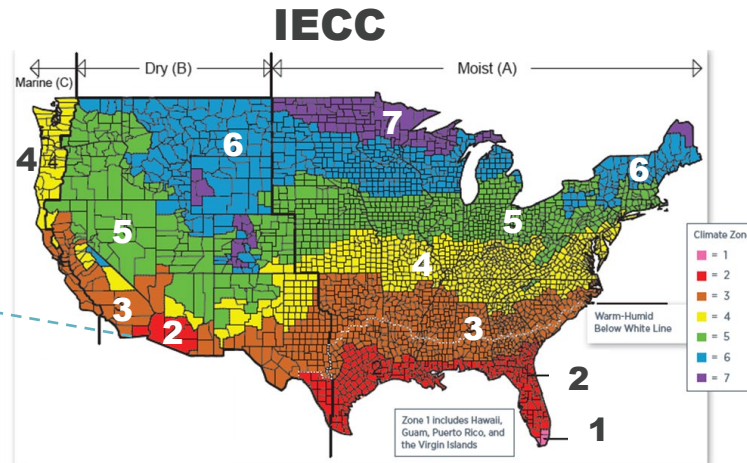
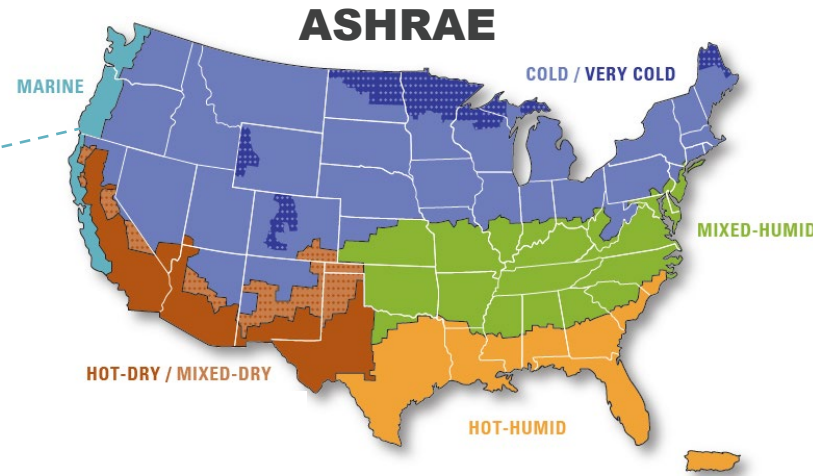
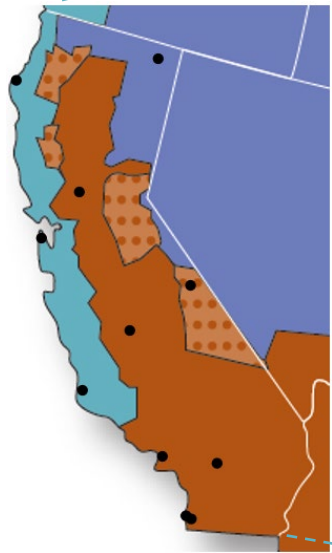

Select Climate Classifications

- **California; 5 zones**
 - **10 cities identified**
 - **San Francisco is in climate zone category Marine 3C**
 - **ASHRAE (Marine), IECC = 3C**

% Time Operating in Transcritical Mode (Supercritical Operation)

California
5 Zones

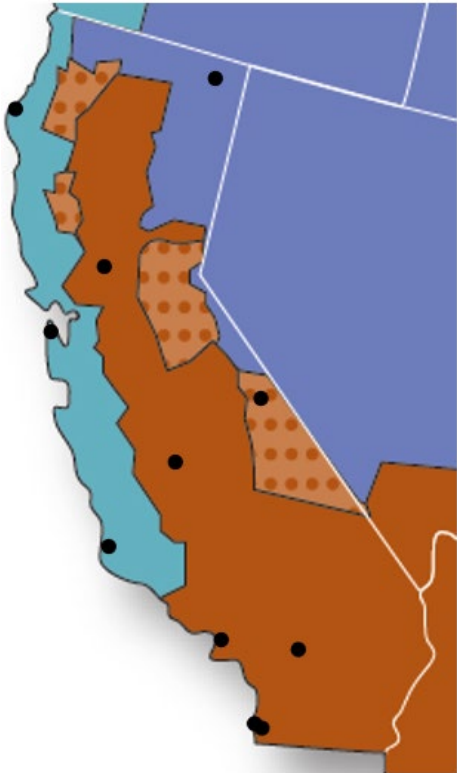

City	ASHRAE	IECC	%TC Dry GC	%TC Adi GC
San Diego	Hot Dry	3B	10%	0.5%
Sacramento	Hot Dry	3B	22%	0%
Los Angeles	Hot Dry	3B	5%	0%
Palm Springs	Hot Dry	3B	54%	6.5%
Fresno Yosemite	Hot Dry	3B	30%	0%
San Francisco	Marine	3C	2%	0%
Santa Maria	Marine	3C	4%	0%
Bishop	Mixed Dry	4B	25%	0%
Arcata	Marine	4C	0.1%	0%
Alturas	Cold	5B	13%	0%

Assumptions: ≥ 75 °F Ambient = Supercritical operation dry gas cooler
 ≥ 72 °F Ambient = Water flow adiabatic gas cooler

Strategies Evaluated



**Dry Gas
Cooler
+ Parallel**

**Adiabatic
Gas Cooler
+ Parallel**

**Dry Gas
Cooler
+ Parallel
+ HP Ejector**

**Adiabatic
Gas Cooler
+ Parallel
+ HP Ejector**

Dry Gas Cooler

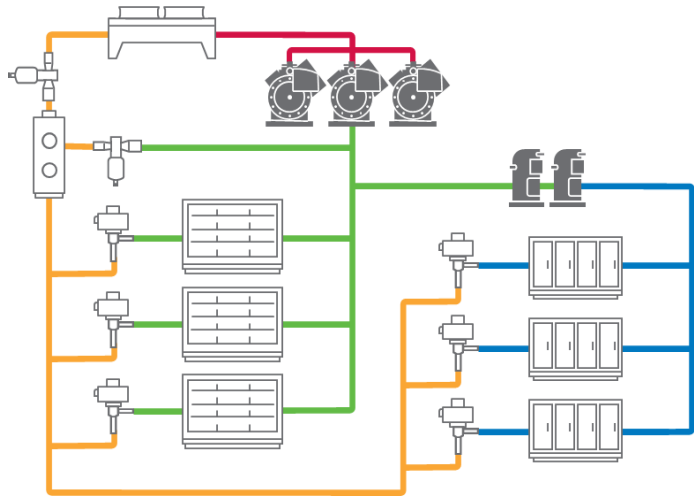

Dry Gas Cooler + Parallel

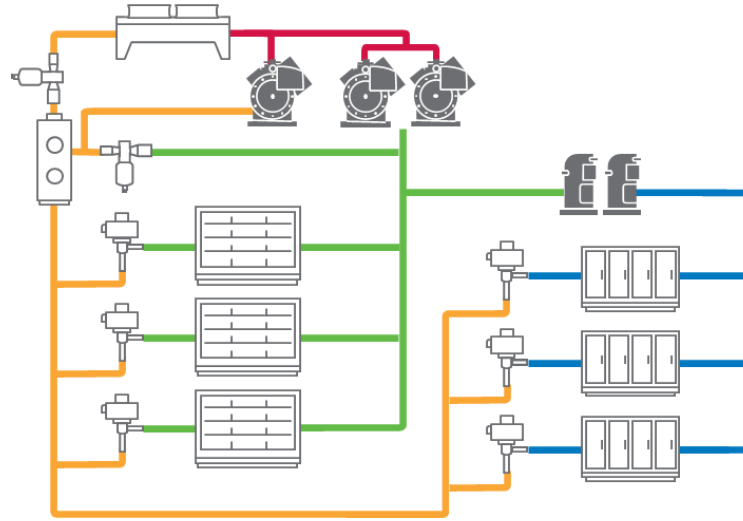

Dry + Parallel + HP Ejector

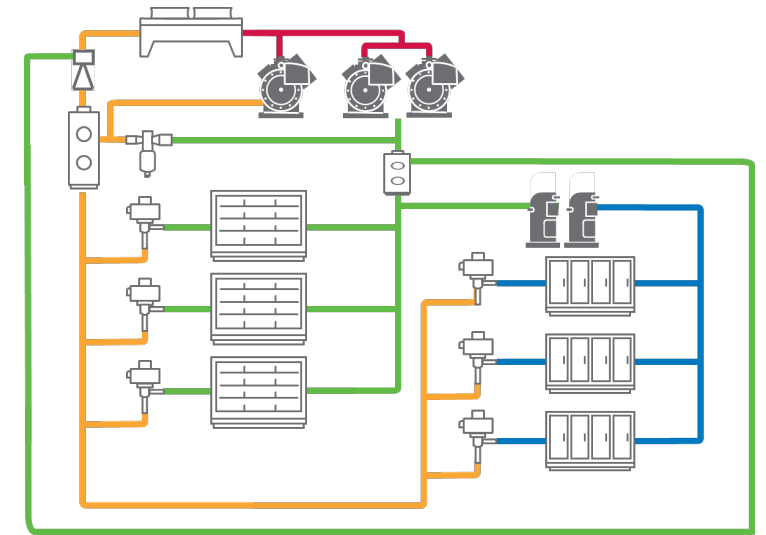

Adiabatic Gas Cooler

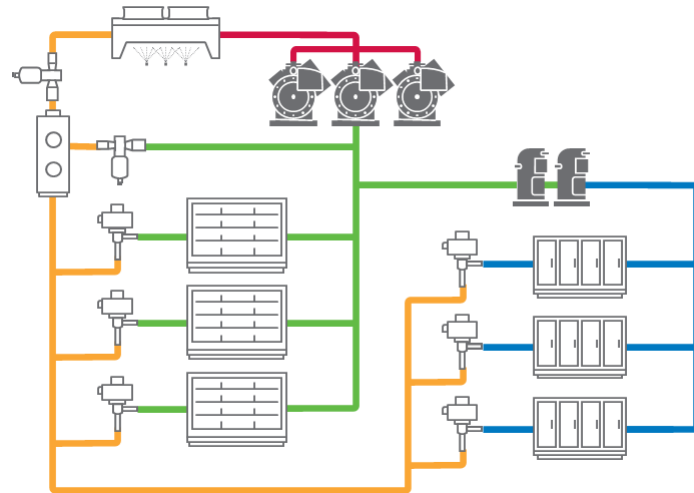

Adiabatic + Parallel

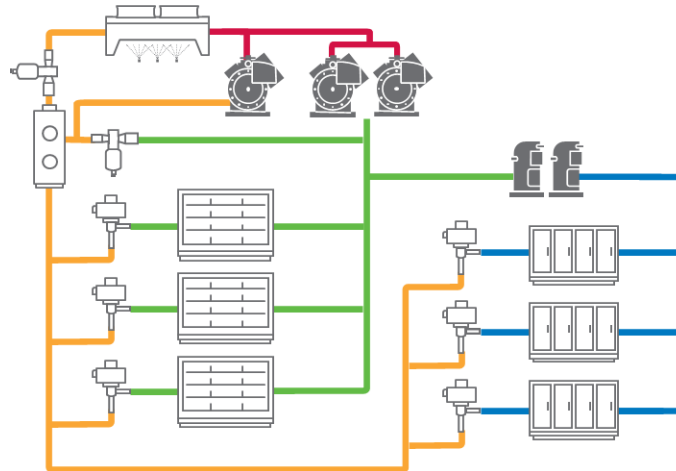

Adiabatic + Parallel + HP Ejector

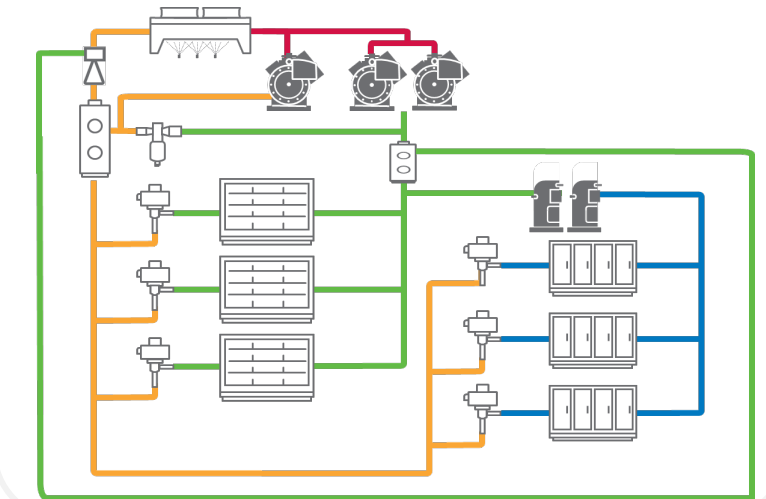

Ave Max Dry Bulb and RH% Per Climate Zone

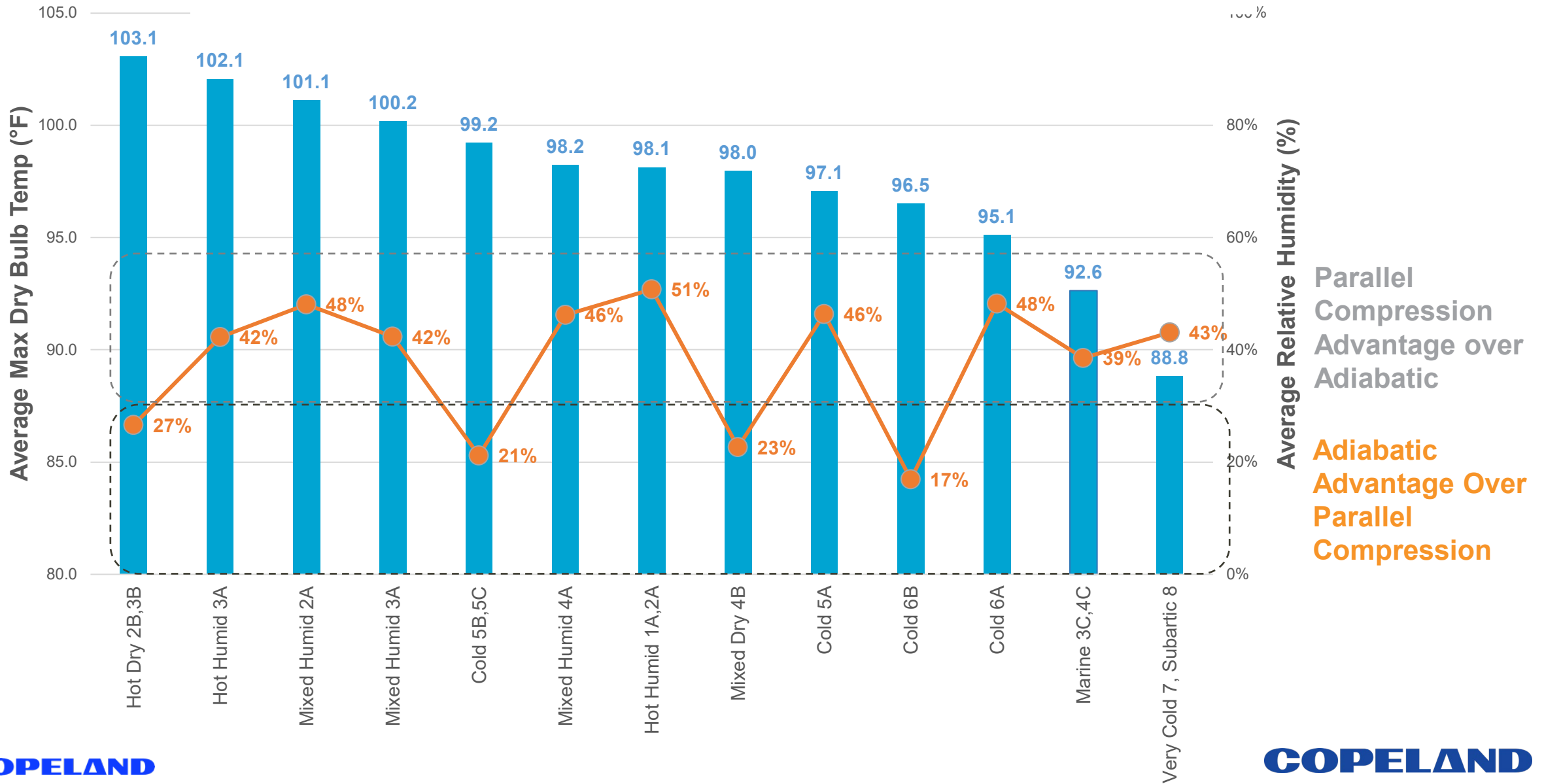

Basic Transcritical CO2 Booster Annual % Runtime Above Critical Point*

% Time in Transcritical Mode

Dry GC

Annual % Time in Transcritical Mode

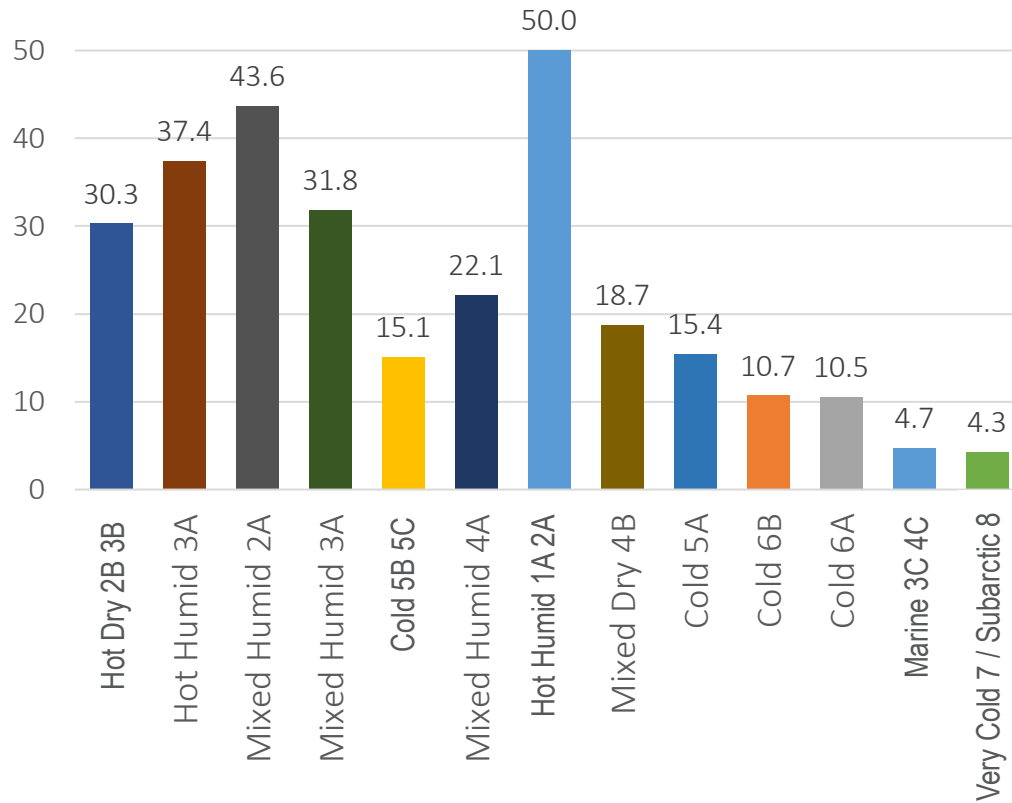

% Time in Transcritical Mode

Adiabatic

Annual % Time in Transcritical Mode

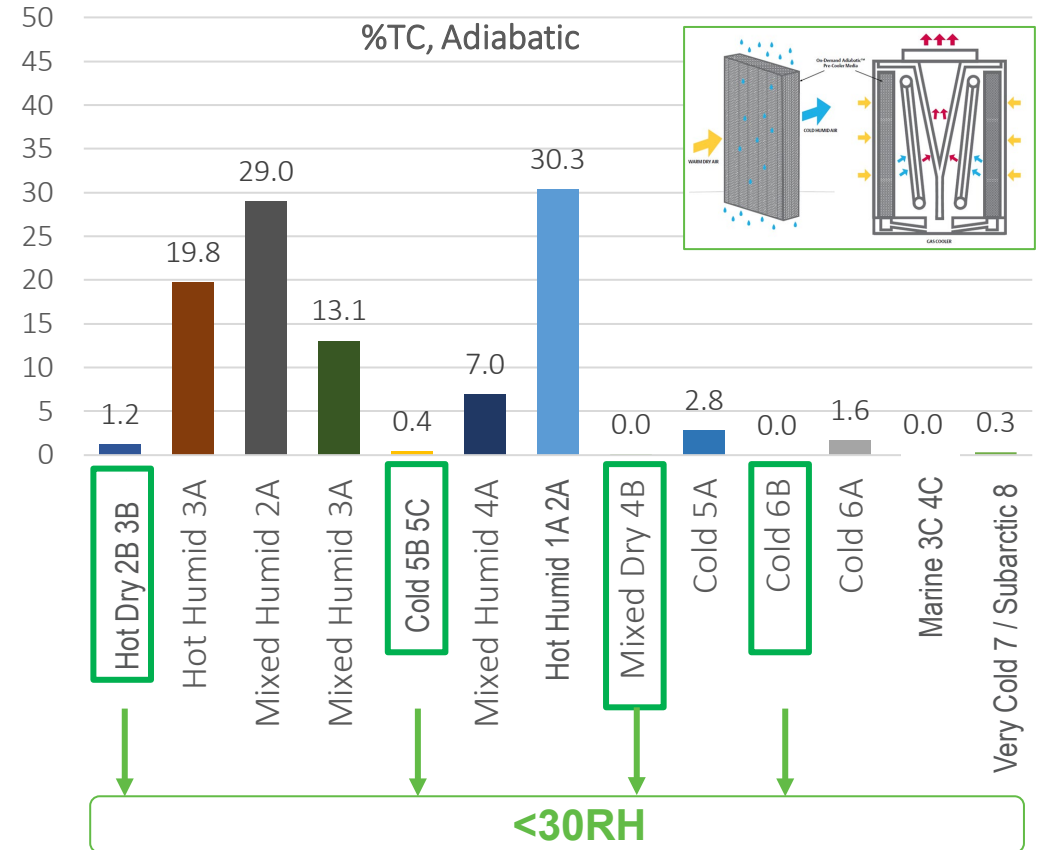

- *Assumptions: ≥ 75 °F Ambient = Supercritical operation dry gas cooler
- ≥ 72 °F Ambient = Water flow adiabatic gas cooler

Percent of Energy Saved vs. Basic TCB Systems

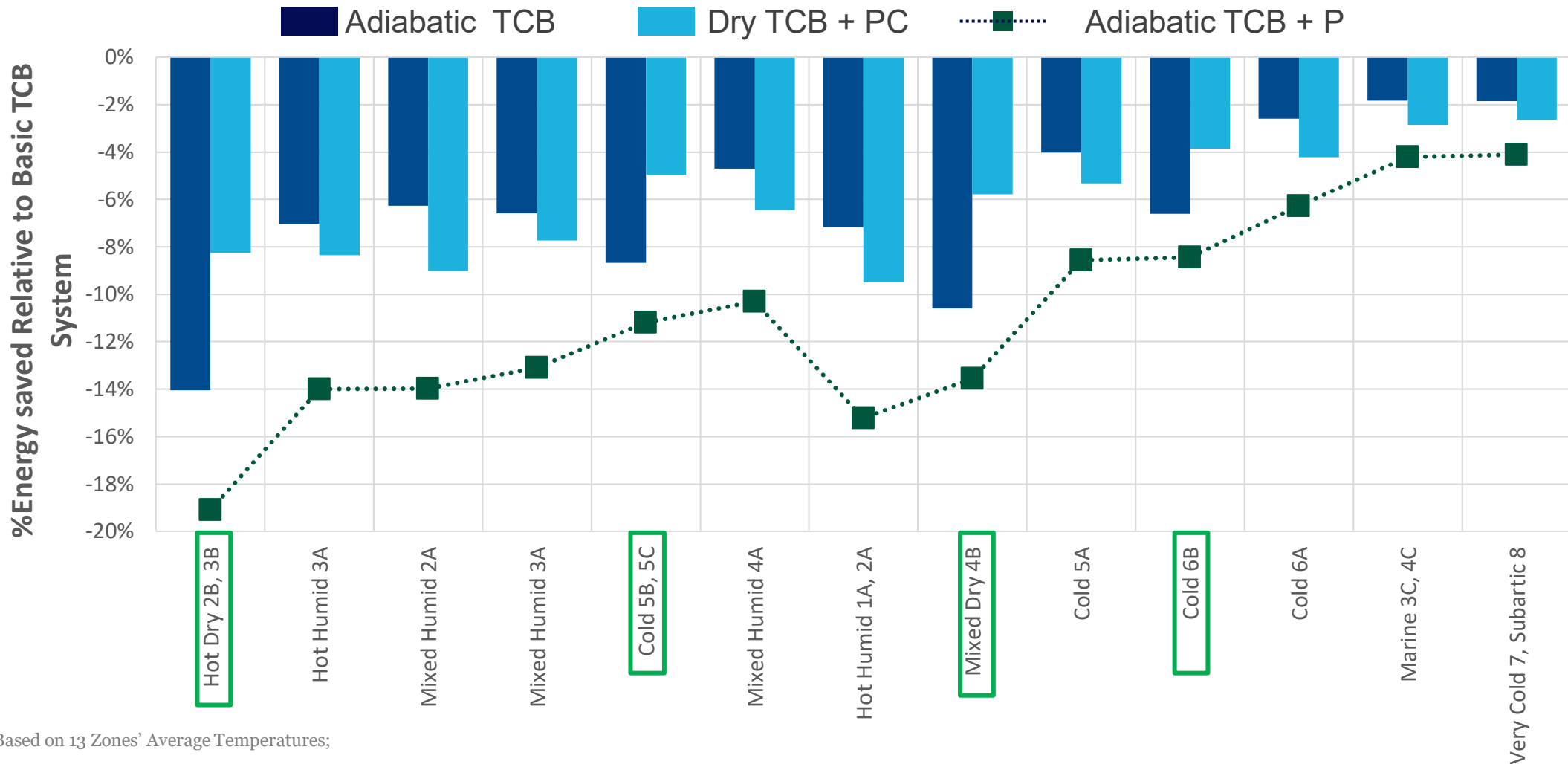

• Charts Based on 13 Zones' Average Temperatures;

• Weather Data: NREL TMY3 data, EES Software, 400MBH MT +18SST, 100MBH LT -20F

Climate Zones with Lower Average Relative Humidity Show Better Energy Reduction With Adiabatic Gas Coolers than with Parallel Compression...

High Pressure Ejectors? Result from Emerson CO2 High Ambient Study

High Pressure Ejector System Requires Parallel Compression By Default

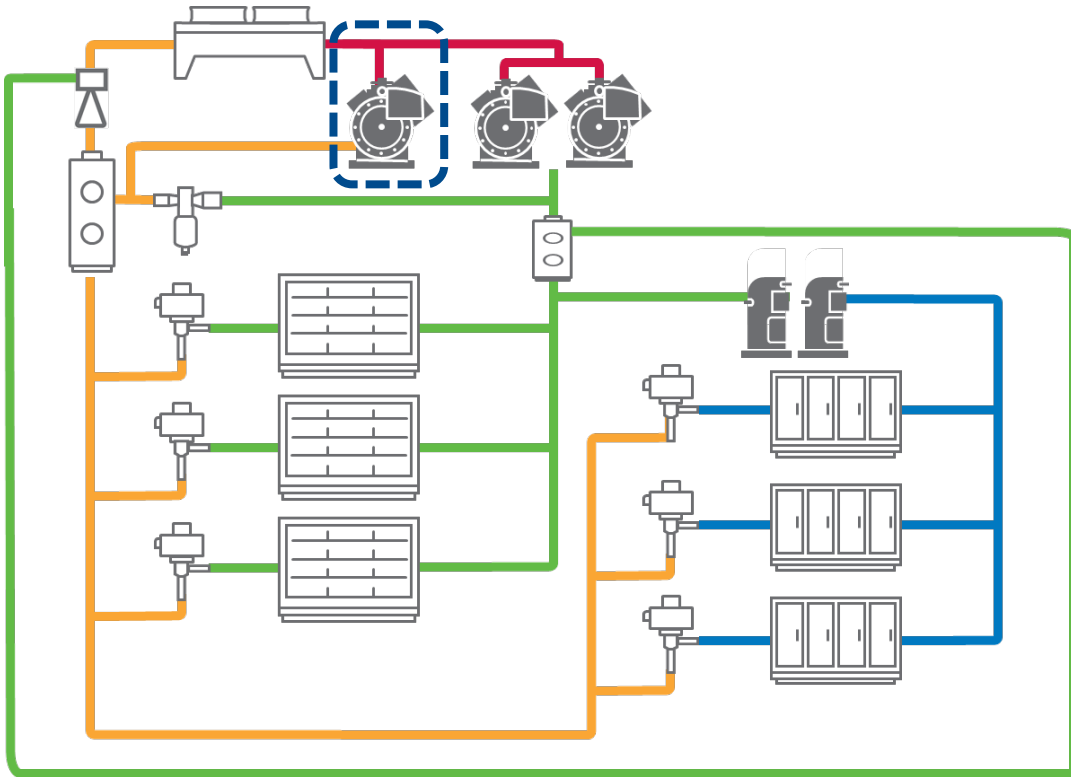

Energy Benefit of Adding Ejectors For Only The Warmest Climate Zones (%Time Dry Cooler TC >18%)

% Energy Reduction Versus TCB+PC*

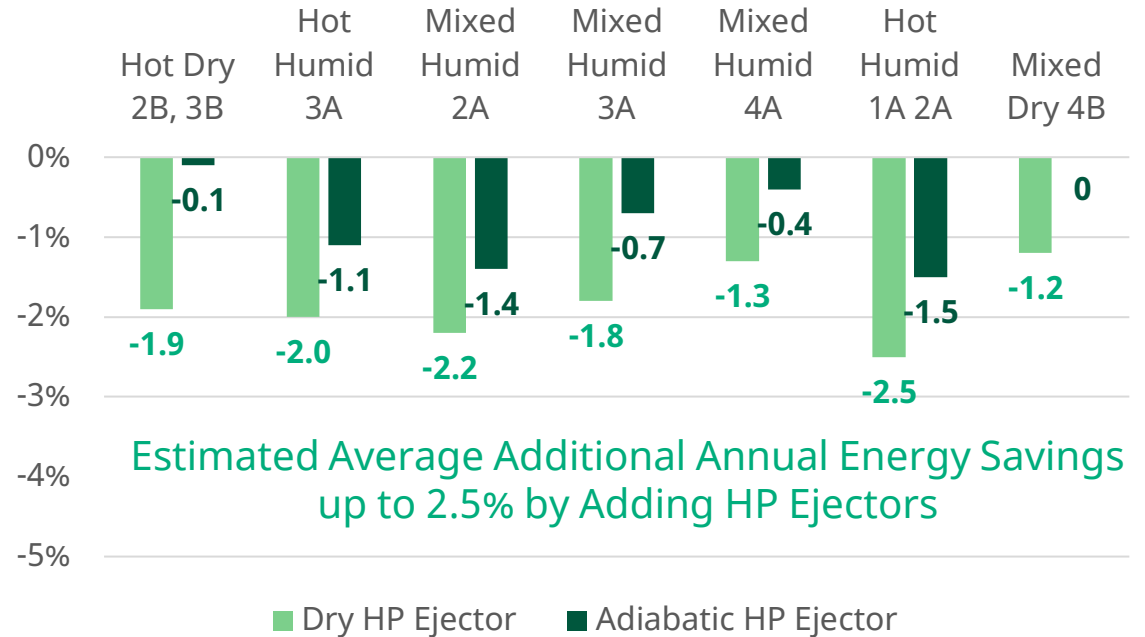

High Pressure Ejectors Add An Estimated 1-3% Annual Energy Reduction Over and Beyond a Transcritical CO2 Booster System with Parallel Compression...

Percent Energy Saved vs. Basic TCB Systems; Climate Zone – Hot Humid 1A 2A – 10 Cities

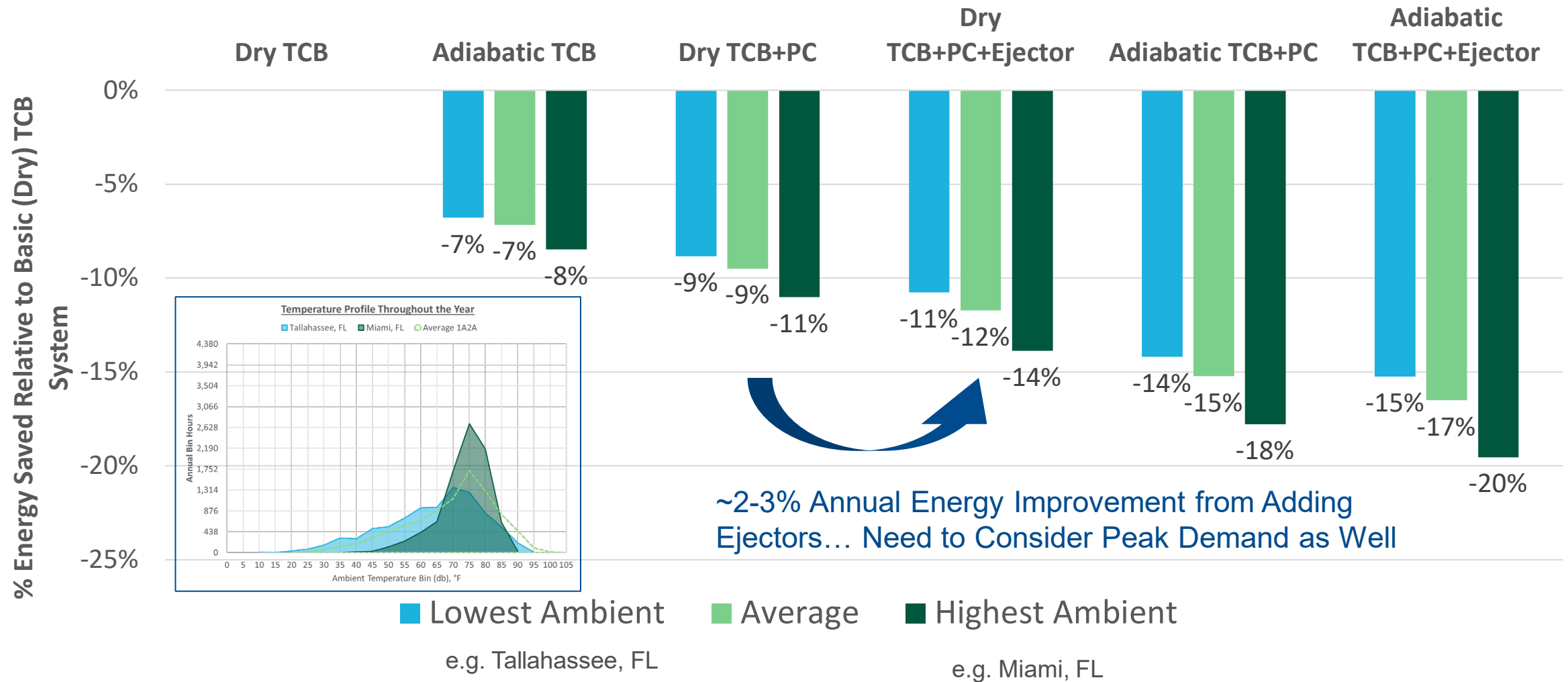

Percent Energy Saving vs. Basic TCB Systems; Climate Zone – Hot Humid 1A 2A – 10 Cities

Parallel Compression for Hot Humid Climate Provides Best Efficiency Improvement; High Pressure Ejector Adds ~2 to 3% More Annual Energy Savings

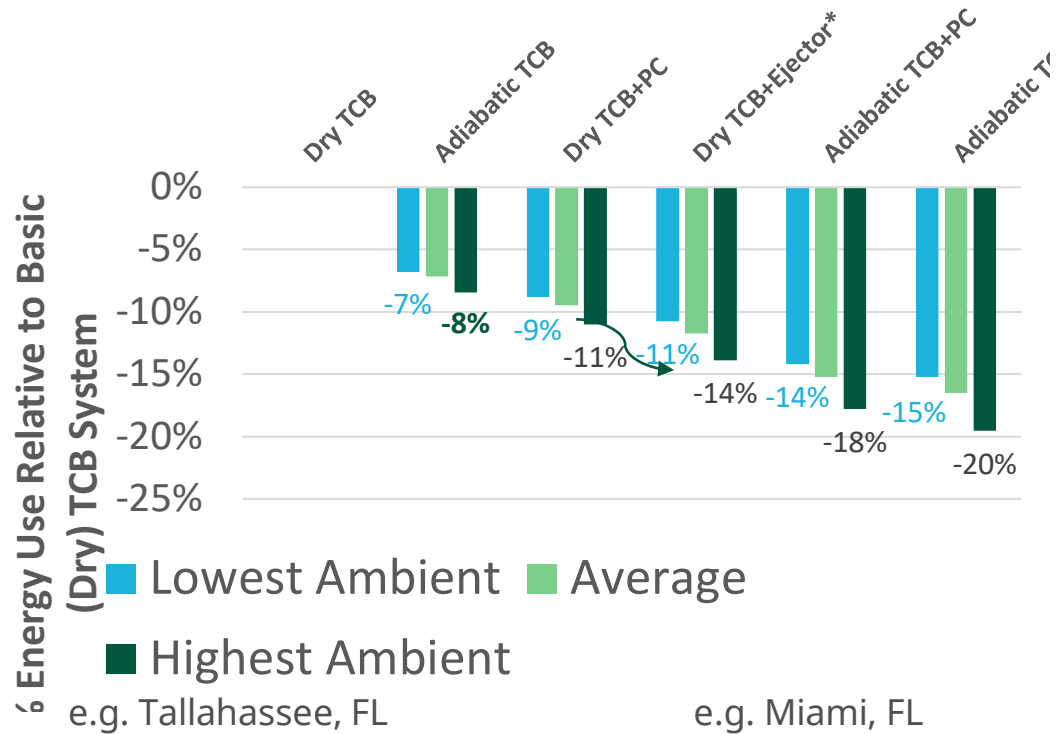

Temperature Profile For Hot Humid 1A/2A Climate Zone

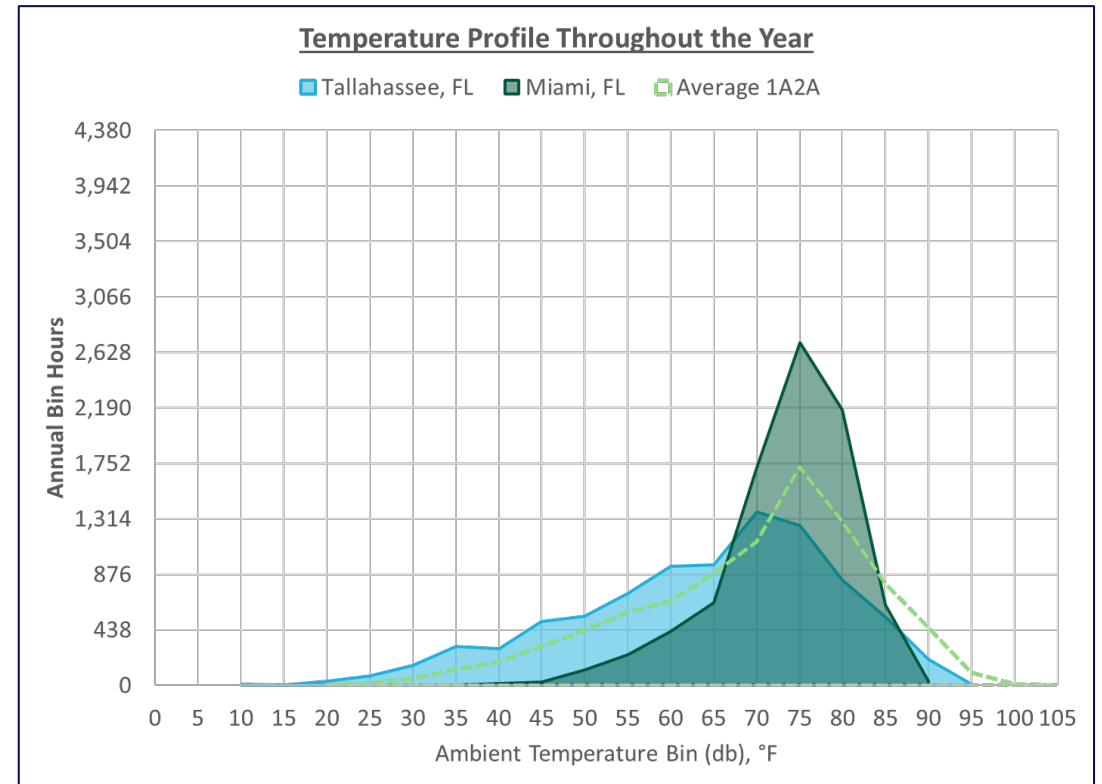

* Systems with HP Ejectors also use Parallel Compression

Example of Peak Power Usage Depending on Refrigeration Strategy

Hot Humid 1A 2A (Florida)

Hot Humid 1A2A Peak Power

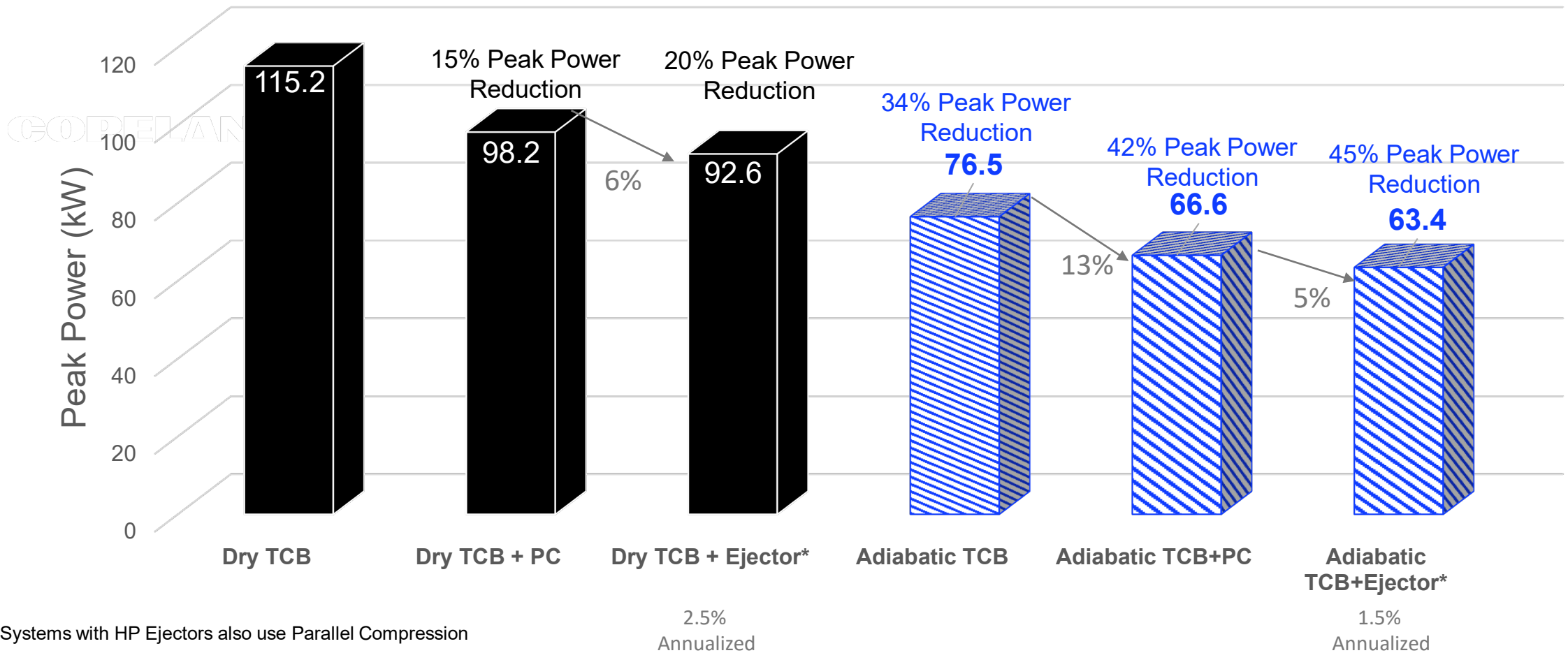

* Systems with HP Ejectors also use Parallel Compression



Peak power consumed when system running in maximum ambient temperature bin. For this climate zone, on average, the dry cooler system may see less than an hour at 105°F ambient and at least one hour at 85°F when using an adiabatic gas cooler. HP Ejectors can reduce peak power an additional 3-5% over parallel compression.

St Louis, MO – Mixed Humid 4A

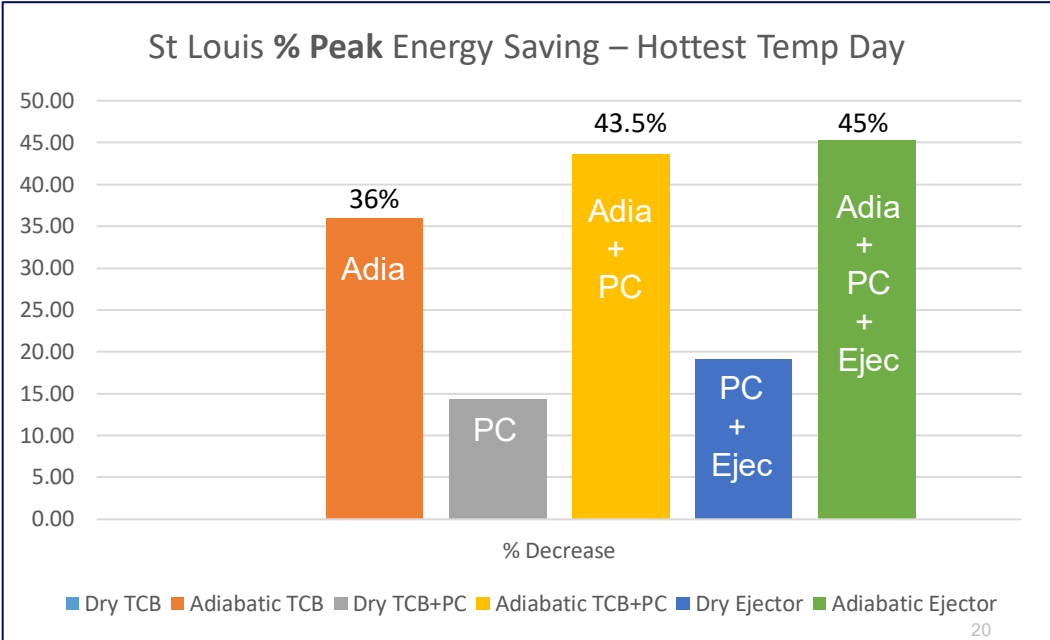
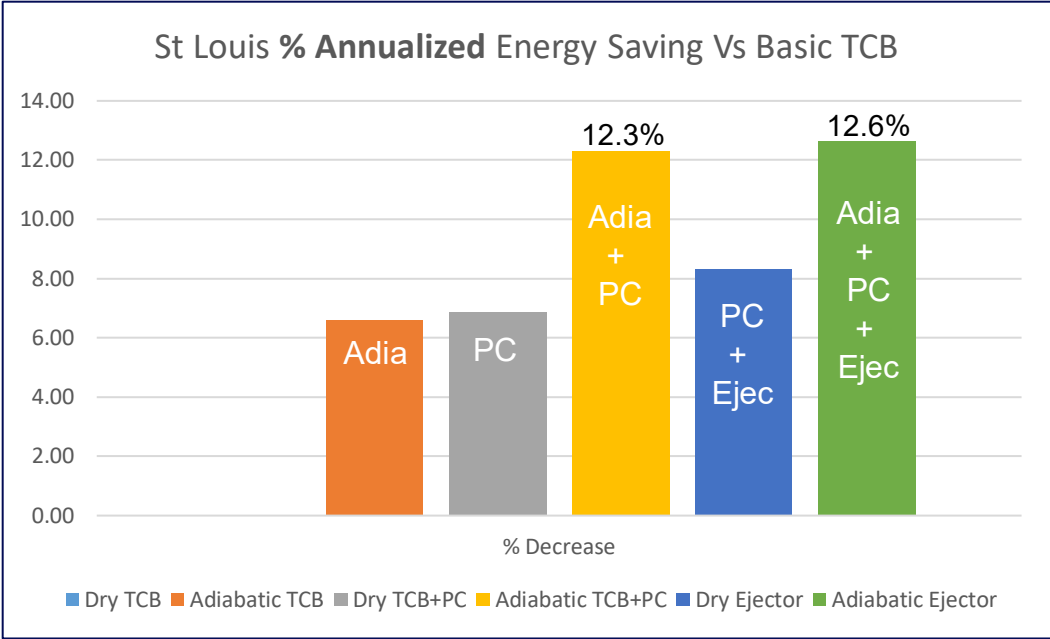
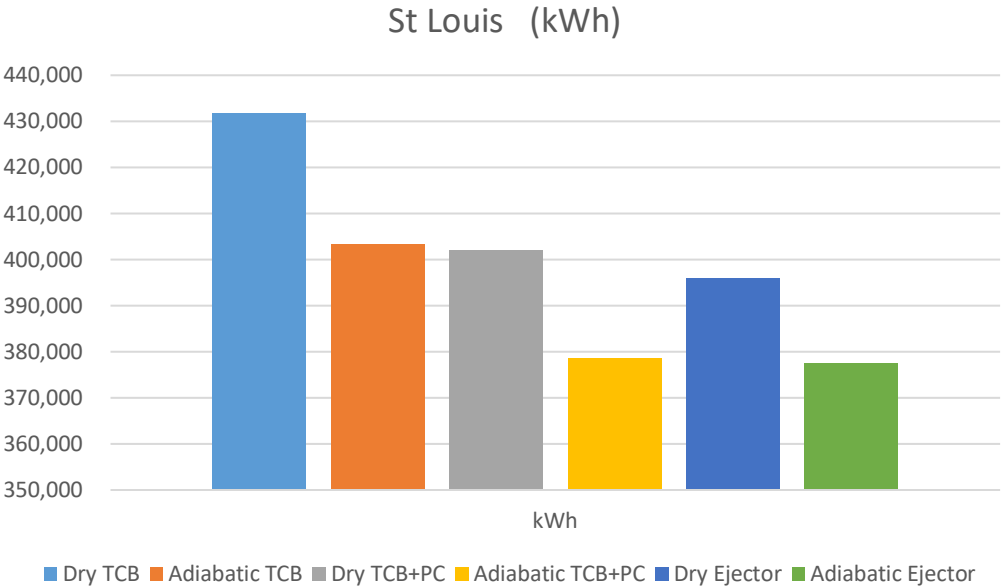

Atlanta, GA – Mixed Humid 3A

Atlanta (kWh)

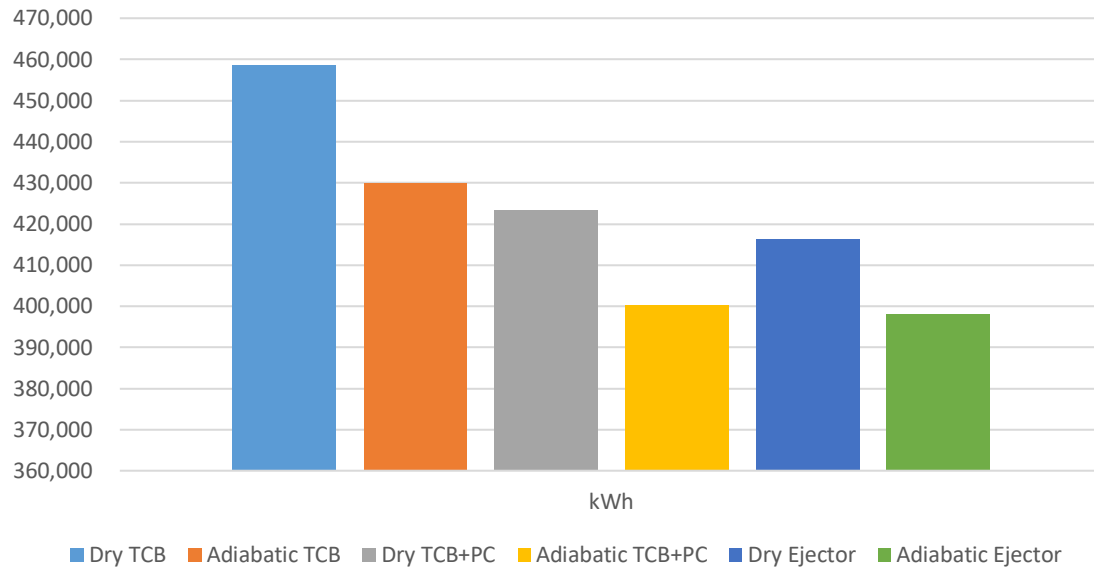

Atlanta (% Annualized Energy Saving Vs Basic TCB)

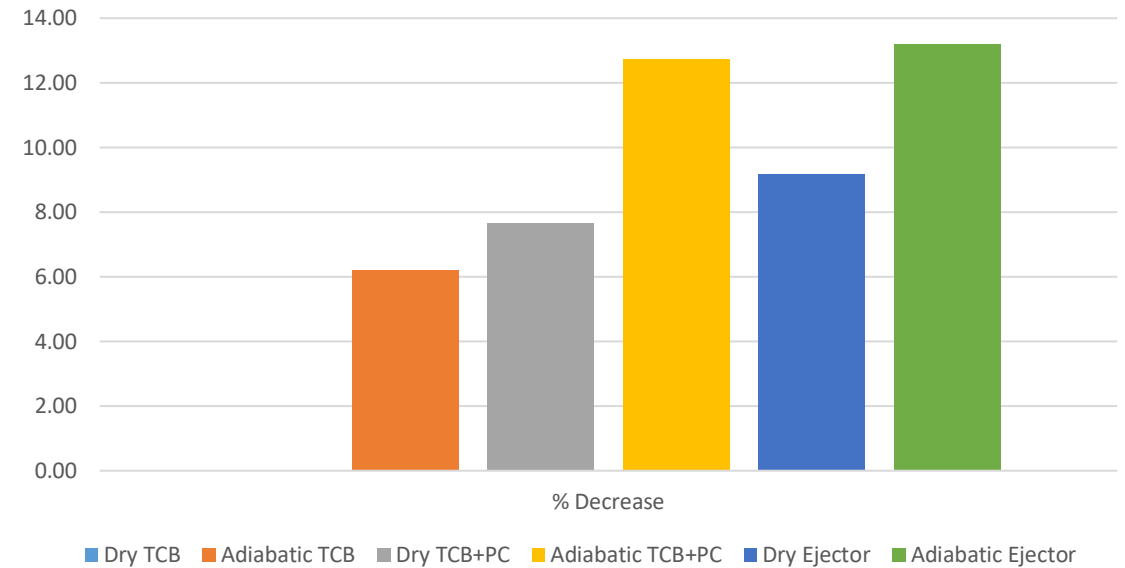

Atlanta	kWh	% Decrease
Dry TCB	458,379	0.00
Adiabatic TCB	429,937	6.20
Dry TCB+PC	423,316	7.65
Adiabatic TCB+PC	400,053	12.72
Dry Ejector	416,299	9.18
Adiabatic Ejector	397,913	13.19

Additional Considerations



Electrical rate

Rate structure, peak demand charges



Water resources

GOPE Availability, cost, sewage charges



Service and maintenance skill levels

Regional CO₂ experience or knowledge gap



Heat reclaim

Volume and intensity requirements



Carbon intensity, electrical generation sources

Impact on Net-zero 2040 goals for scope 2 emissions



Carbon Credits

Summary

This study was commissioned to provide industry stakeholders with an unbiased third-party engineering evaluation of energy comparison of the most common high ambient strategies to support the uptake with CO₂ Transcritical booster systems for the supermarket industry.

COPELAND

Total Cost of Ownership

Andre Patenaude

Nov.16, 2023



Disclaimer

This presentation is intended to highlight changing developments in the law and industry topics. The law is frequently evolving and information and publications in this presentation may not reflect the latest changes in the law or legal interpretations. The statements and information provided in this presentation should not be construed as legal advice or legal opinion regarding any specific facts or circumstances, but is intended for general informational purposes only. The views and statements expressed during this presentation are the personal opinions of the presenter and do not represent those of Emerson Climate Technologies, Inc., Hussmann Corporation or its affiliated companies. You should consult an attorney about your situation and specific facts and you should not act on any of the information in this presentation as the information may not be applicable to your situation. Although all statements and information contained herein are believed to be accurate and reliable, they are presented without warranty of any kind. Information provided herein does not relieve the user from the responsibility of carrying out its own tests and experiments. Statements or suggestions concerning the use of materials and processes are made without representation or warranty that any such use is free of patent infringement and are not recommendations to infringe on any patents. This presentation may not be copied or redistributed without the express written consent of Emerson Climate Technologies, Inc. and Hussmann Corporation.

Total Cost of Ownership Study - Partners

HUSSMANN®

**Cushing
Terrell**

COPELAND

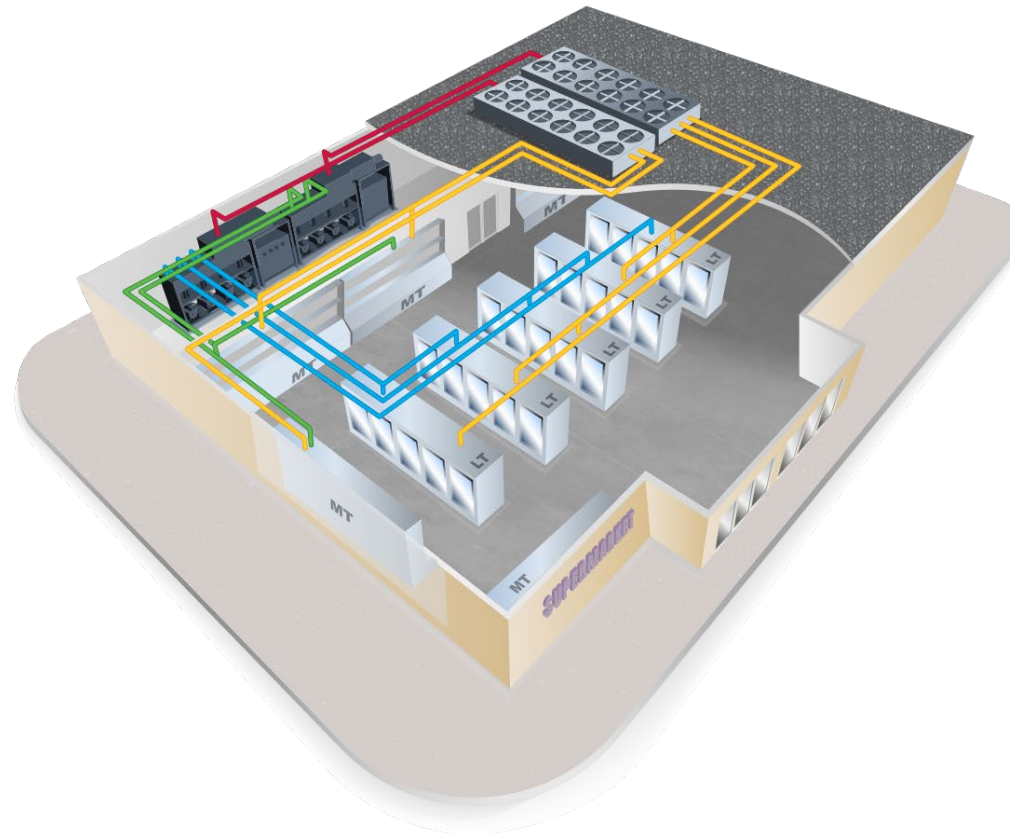

Total Cost of Ownership Study

Architecture Options

1. Centralized DX
2. Distributed Scroll
3. Condensing Units
4. CO2 Booster (Adiabatic)
5. CO2 Booster
6. R290 Micro Distributed
7. Scroll Booster

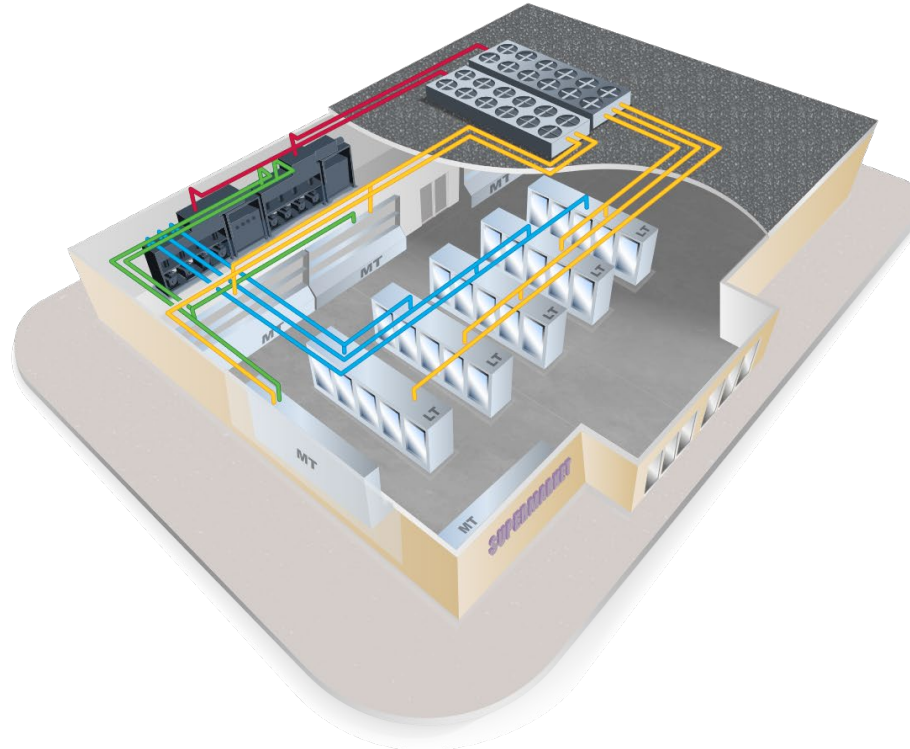

Specifications

- ✓ 25,000 ft² Store Size
- ✓ 450MBH MT (30 Cases + 5 Coolers)
- ✓ 91MBH LT (16 Cases + 1 Freezer)
- ✓ Schedules for each;
 - ✓ Refrigeration
 - ✓ Electrical
- ✓ Floor Plans for each;
 - ✓ Refrigeration
 - ✓ Electrical
- ✓ LCCP Analysis

Desired Outputs: To understand the Total Cost of Ownership Relative to Centralized HFC
All Equipment, Installation, Commissioning, Service, Maintenance over 20 years

Layout Consistent Across All Systems

- 450 MBH MT
- 91 MBH LT

8x Refrigeration Schedules

Equipment	Capacity (MBH)	Operating Hours	Notes
MT Case 1	15	24/7	
MT Case 2	15	24/7	
MT Case 3	15	24/7	
MT Case 4	15	24/7	
MT Case 5	15	24/7	
MT Case 6	15	24/7	
MT Case 7	15	24/7	
MT Case 8	15	24/7	
MT Case 9	15	24/7	
MT Case 10	15	24/7	
MT Case 11	15	24/7	
MT Case 12	15	24/7	
MT Case 13	15	24/7	
MT Case 14	15	24/7	
MT Case 15	15	24/7	
MT Case 16	15	24/7	
MT Case 17	15	24/7	
MT Case 18	15	24/7	
MT Case 19	15	24/7	
MT Case 20	15	24/7	
MT Case 21	15	24/7	
MT Case 22	15	24/7	
MT Case 23	15	24/7	
MT Case 24	15	24/7	
MT Case 25	15	24/7	
MT Case 26	15	24/7	
MT Case 27	15	24/7	
MT Case 28	15	24/7	
MT Case 29	15	24/7	
MT Case 30	15	24/7	
LT Case 1	5	24/7	
LT Case 2	5	24/7	
LT Case 3	5	24/7	
LT Case 4	5	24/7	
LT Case 5	5	24/7	
LT Case 6	5	24/7	
LT Case 7	5	24/7	
LT Case 8	5	24/7	
LT Case 9	5	24/7	
LT Case 10	5	24/7	
LT Case 11	5	24/7	
LT Case 12	5	24/7	
LT Case 13	5	24/7	
LT Case 14	5	24/7	
LT Case 15	5	24/7	
LT Case 16	5	24/7	
Freezer	10	24/7	

8x Refrigeration Floor Plan

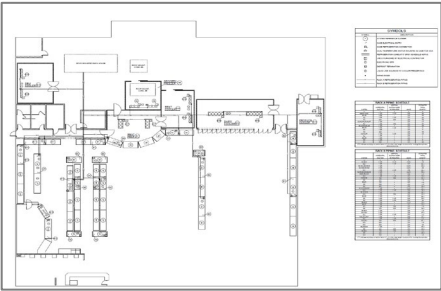

8x Electrical Floor Plans

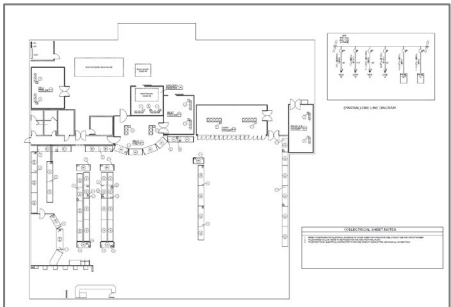

8x Electrical Schedules

Equipment	Capacity (MBH)	Operating Hours	Notes
MT Case 1	15	24/7	
MT Case 2	15	24/7	
MT Case 3	15	24/7	
MT Case 4	15	24/7	
MT Case 5	15	24/7	
MT Case 6	15	24/7	
MT Case 7	15	24/7	
MT Case 8	15	24/7	
MT Case 9	15	24/7	
MT Case 10	15	24/7	
MT Case 11	15	24/7	
MT Case 12	15	24/7	
MT Case 13	15	24/7	
MT Case 14	15	24/7	
MT Case 15	15	24/7	
MT Case 16	15	24/7	
MT Case 17	15	24/7	
MT Case 18	15	24/7	
MT Case 19	15	24/7	
MT Case 20	15	24/7	
MT Case 21	15	24/7	
MT Case 22	15	24/7	
MT Case 23	15	24/7	
MT Case 24	15	24/7	
MT Case 25	15	24/7	
MT Case 26	15	24/7	
MT Case 27	15	24/7	
MT Case 28	15	24/7	
MT Case 29	15	24/7	
MT Case 30	15	24/7	
LT Case 1	5	24/7	
LT Case 2	5	24/7	
LT Case 3	5	24/7	
LT Case 4	5	24/7	
LT Case 5	5	24/7	
LT Case 6	5	24/7	
LT Case 7	5	24/7	
LT Case 8	5	24/7	
LT Case 9	5	24/7	
LT Case 10	5	24/7	
LT Case 11	5	24/7	
LT Case 12	5	24/7	
LT Case 13	5	24/7	
LT Case 14	5	24/7	
LT Case 15	5	24/7	
LT Case 16	5	24/7	
Freezer	10	24/7	

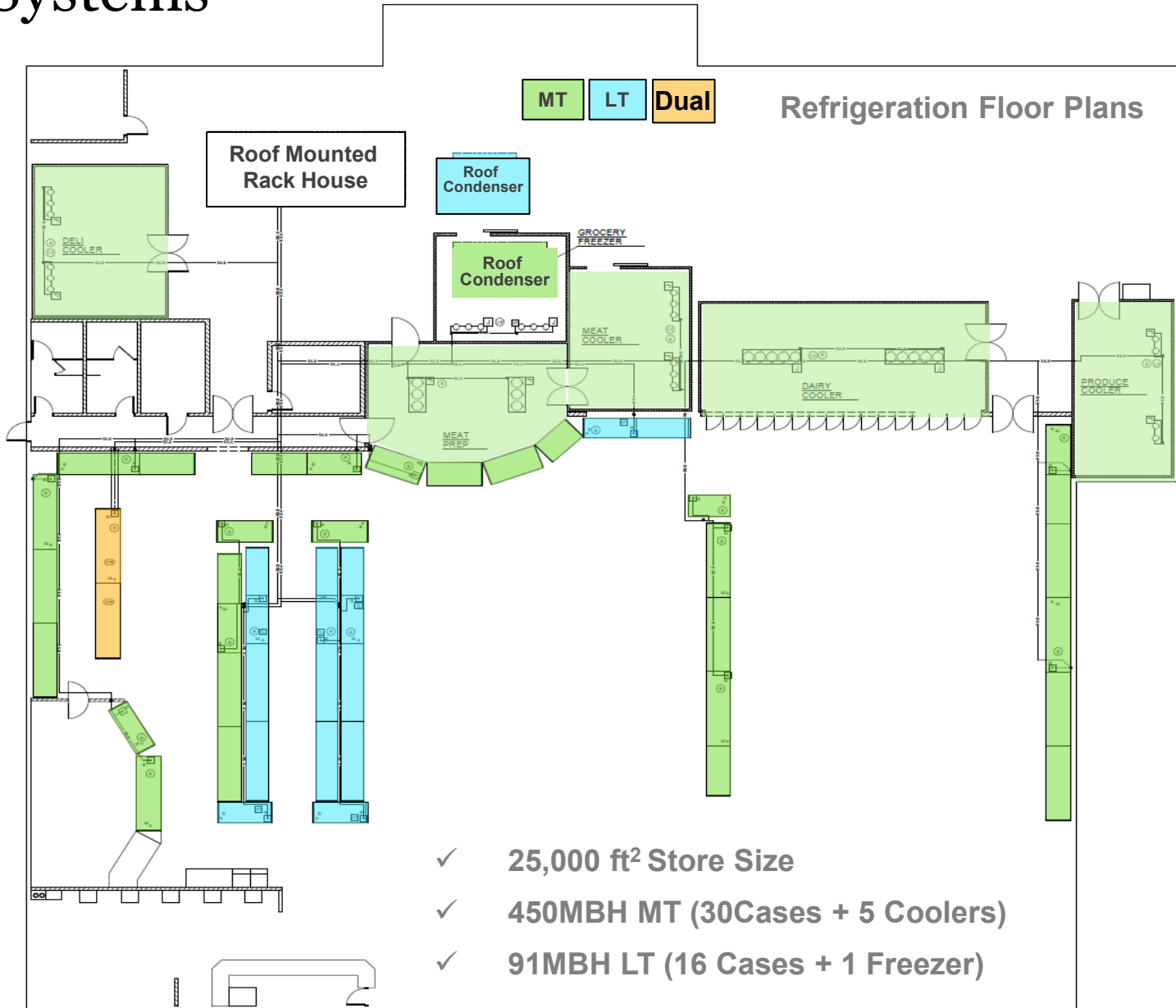

System Comparisons

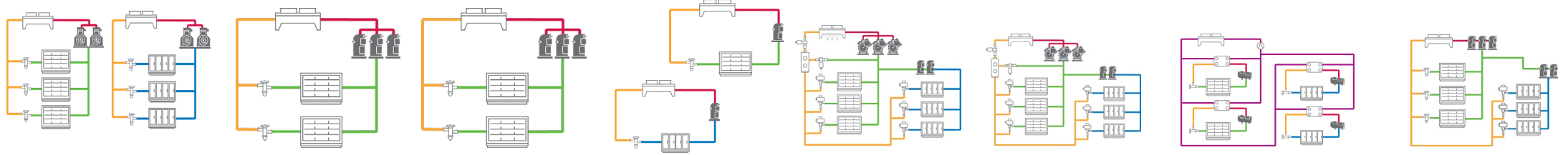

	Traditional HFC Rack	Distributed Scroll	Distributed Scroll (A2L)	Condensing Unit	CO2 Booster With Adiabatic	CO2 Booster	Micro DS Adiabatic	Scroll Booster (MT/LT Packs)
# of Compressors	9	15	15-16	27	7	7	52	17
Case Controls	✗	✗	✗	✗	✓	✓	✓	✗
Refrigerant	R-448A	R-448A	R-454C	R-448A	CO2	CO2	R-290	R-513A
Expansion Valve	TXV	TXV	TXV	TXV	EEV	EEV	Capillary Tube / TXV	TXV
Condenser / Gas Cooler	Dry	Dry	Dry	Dry	Adiabatic (Water Required)	Dry	Adiabatic (Water Required)	Dry
Control	Centralized	Distributed	Distributed	Distributed	Distributed w/ Case Control	Distributed w/ Case Control	Distributed w/ Case Control	Centralized
Challenges	High AWGWP Obsolete in CA High Leak Rates	Meeting regulations with GWP	A2L approval and building code timing	27 Units to Service 27 Condensers to clean	Leaks Complexity, Technicians Highest CapEx	Leaks Complexity, Technicians Peak Energy	Annual Energy 52 Units to Service Units/Cases /Sales Floor	Larger Displacement Compressors Charge <50lb for Now

Assumptions

System Specifications - 25,000 ft ² Store Size - 450MBH MT (30 Cases + 5 Coolers) - 91MBH LT (16 Cases + 1 Freezer)	HFC Centralized Racks		HFC Distributed Systems		HFC Condensing Units		CO2 Cascade		CO2 Booster		Micro-Distributed		Scroll Booster LT Compressor Unit into MT Scroll Pack		Scroll Booster LT Scroll Pack into MT Scroll Pack	
	HFC Centralized Racks		HFC Distributed Systems		HFC Condensing Units		CO2 Cascade		CO2 Booster		Micro-Distributed		Scroll Booster LT Compressor Unit into MT Scroll Pack		Scroll Booster LT Scroll Pack into MT Scroll Pack	
	R448A	kBtu	R448A	kBtu	R448A	kBtu	CO2/R513A	kBtu	CO2	kBtu	R290	kBtu	R513A	kBtu	R513A	kBtu
LT Load		90.8		90.8		90.9		90.8		90.8		87.422		91		90.839
MT Load		417.6		417.6		417.7		417.6		417.6		421.259		417.5		417.5
Total Load		508.4		508.4		508.6		508.4		508.4		508.681		508.5		508.339
Condenser TD	LT: 10 MT: 15	°F °F	LT: 10 MT: 15	°F °F	LT: 20 MT: 20	°F °F	MT: 15	°F	SC: 5, TC: 10	°F	Water Cooler: 15 Unit2: 10	°F °F	MT: 15	°F	MT: 15	°F
Comp RG	LT: 40 MT: 65	°F °F	LT: 40 RG MT: 50 RG	°F °F	LT: 20 SH MT: 40 SH	°F °F	LT: 36 SH MT: 65	°F °F	SC: 36 SH, TC: 18 SH	°F	20 SH	°F	LT: 20 SH, MT 65 RG	°F	LT: 40 SH, MT 65 RG	°F
Min Cond	70	°F	70	°F	70	°F	70	°F	50	°F	60	°F	70	°F	70	°F
Leak Rate	0.15		0.1		0.05		0.15		0.15		0.05		0.15		0.15	
GWP (AR4)	1387		1387		1387		1/1387		1		3/1387		631		631	
Charge	LT: 460 lbs MT: 790 lbs 1250 lbs		LT: 380 lbs MT1: 450 lbs MT2: 580 lbs 1410 lbs		A1 A2 A3 A4	20.3 33.4 20.3 33.4	LT: 260 lbs MT: 560 lbs 820 lbs		LT: 140 lbs MT: 560 lbs 700 lbs		A1 A2 A3 A4	0.661387 0.661387 0.99208 0.99208	System 1: 470 lbs System 2: 450 lbs Total: 920 lbs		System 1: 470 lbs System 2: 450 lbs Total: 920 lbs	

Total Cost of Ownership Study – Architectures

**HFC Centralized
R448/9A**

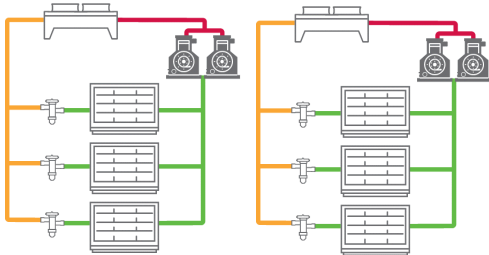

**Distributed Scroll Pack
R448/9A**

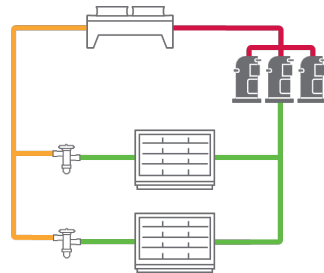

**Single Condensing Units
R448/9A**

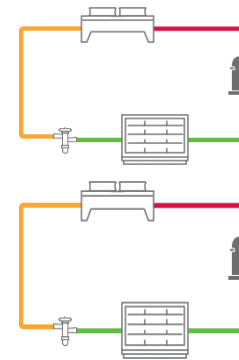

**Transcritical Booster
CO2 (Adiabatic)**

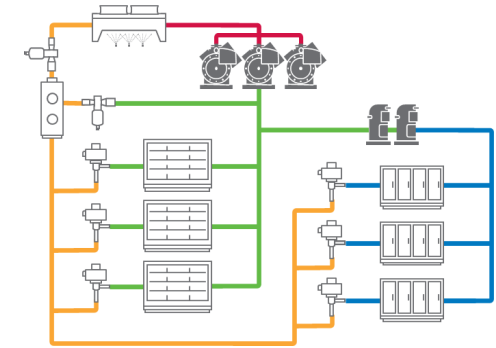

**Transcritical Booster
CO2 (Non-Adiabatic)**

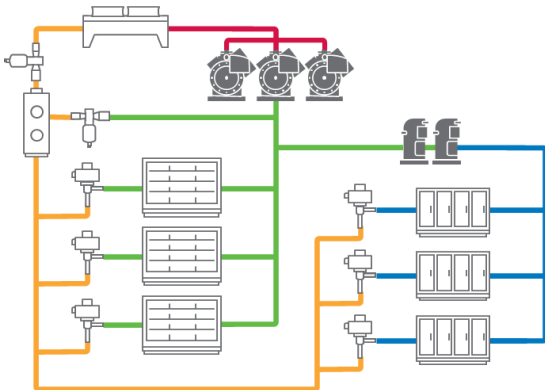

**Micro Distributed
R290 Water Cooled (Adiabatic)**

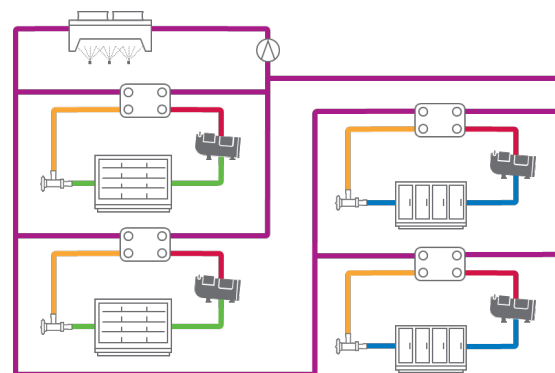

**Scroll Booster
LT Rack into MT Rack
R513A**

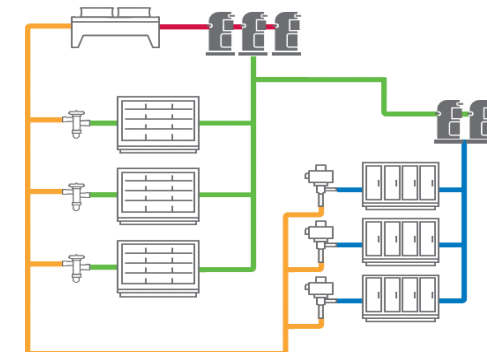

Scroll Booster

Basic Design:

- Future Potential CARB Compliant A2L Capable <150 GWP
 - 170lbs Releasable (UL-60335-2-89 Standard)
- Multiple Configuration Creates Flexibility
- Grocery Store, C-Stores, Restaurant, etc
- R513A (~600 GWP) Both MT & LT
- Low Pressure, Low Leaks Rates
- High Ambient Friendly, Low Discharge Temps
- Low Compression Ratio
- LT Loads w/Unit per Case; Dual Temp Capable
- High Reliability
- Simple Layout
- No Specialized Training

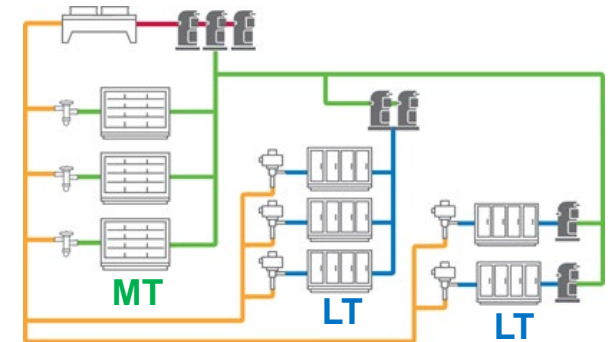
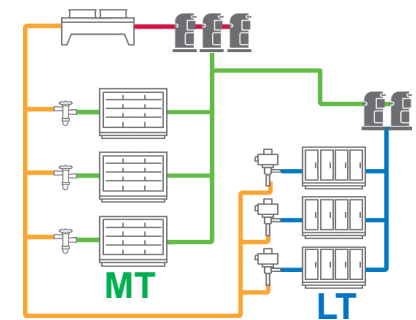
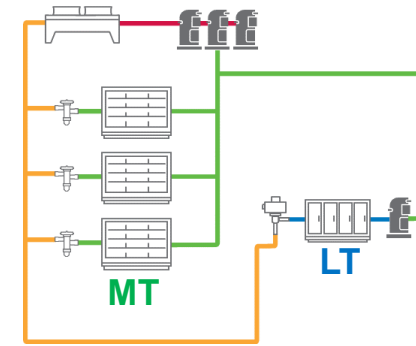

Location Assessments

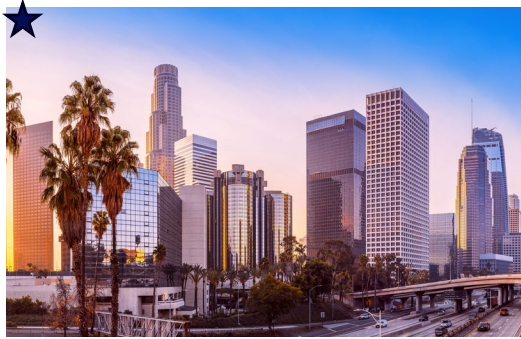

Los Angeles

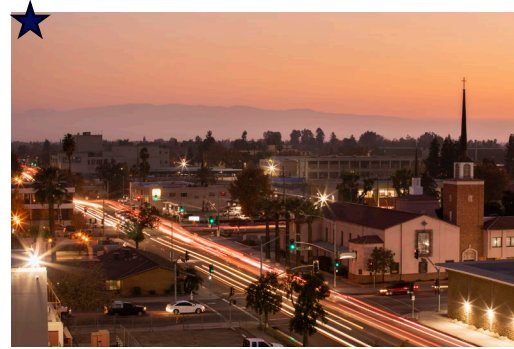

Bakersfield

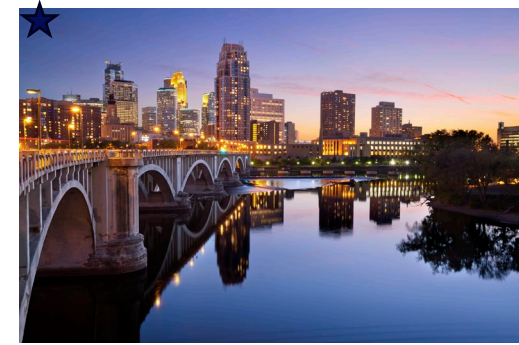

Minneapolis



San Francisco

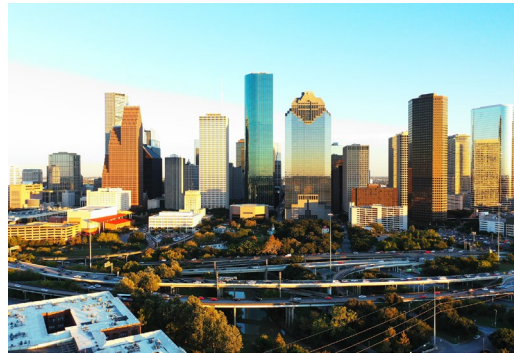

Houston

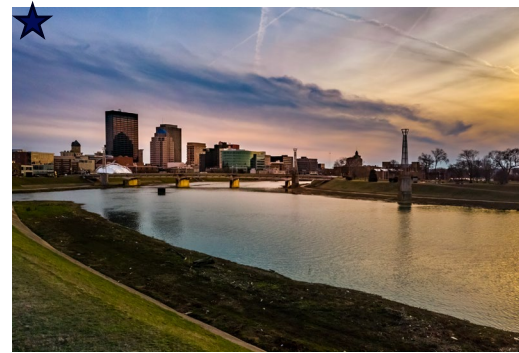

Dayton

Los Angeles



Los Angeles Energy Comparison

Annual Energy vs Peak Power, Los Angeles

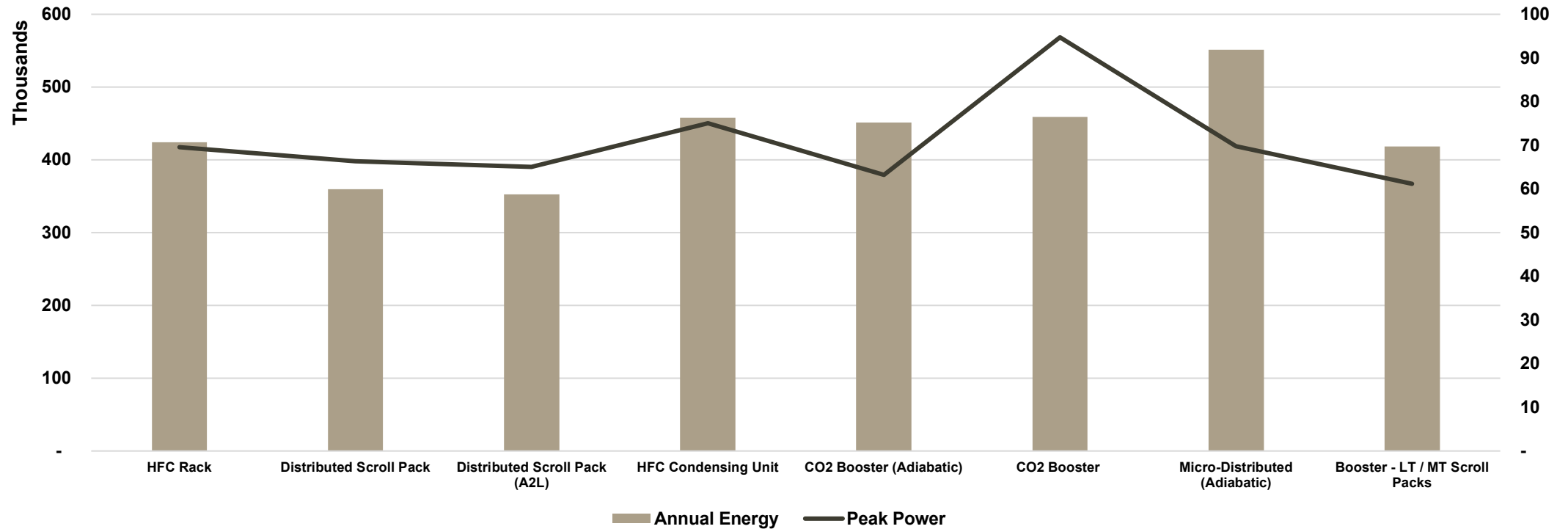

	HFC Rack	Distributed Scroll Pack	HFC Condensing	CO2 Booster (Adiabatic)	CO2 Booster	Micro-Distributed (Adiabatic)	Booster - LT / MT Scroll Packs
Annual Energy (Los Angeles)	424,581	360,108	458,144	451,696	459,383	551,154	418,793
\$ Usage (Based on \$0.11/KWh)	\$ 46,704	\$ 39,612	\$ 50,396	\$ 49,687	\$ 50,532	\$ 60,627	\$ 46,067
Peak Power	70	66	75	63	95	70	61
Peak Power \$ (Based on \$25kW)	\$ 20,888	\$ 19,914	\$ 22,517	\$ 18,985	\$ 28,434	\$ 20,944	\$ 18,372
Annual total Power	\$ 67,592	\$ 59,525	\$ 72,913	\$ 68,671	\$ 78,967	\$ 81,571	\$ 64,439



Notes: Condensing unit energy modeled based on 20°F TD (MT and LT) with min 70° F SCT and 40° F superheat
Cycling losses not included in energy comparisons. Energy assessment based on constant load.

Los Angeles Annualized CO2 Emissions

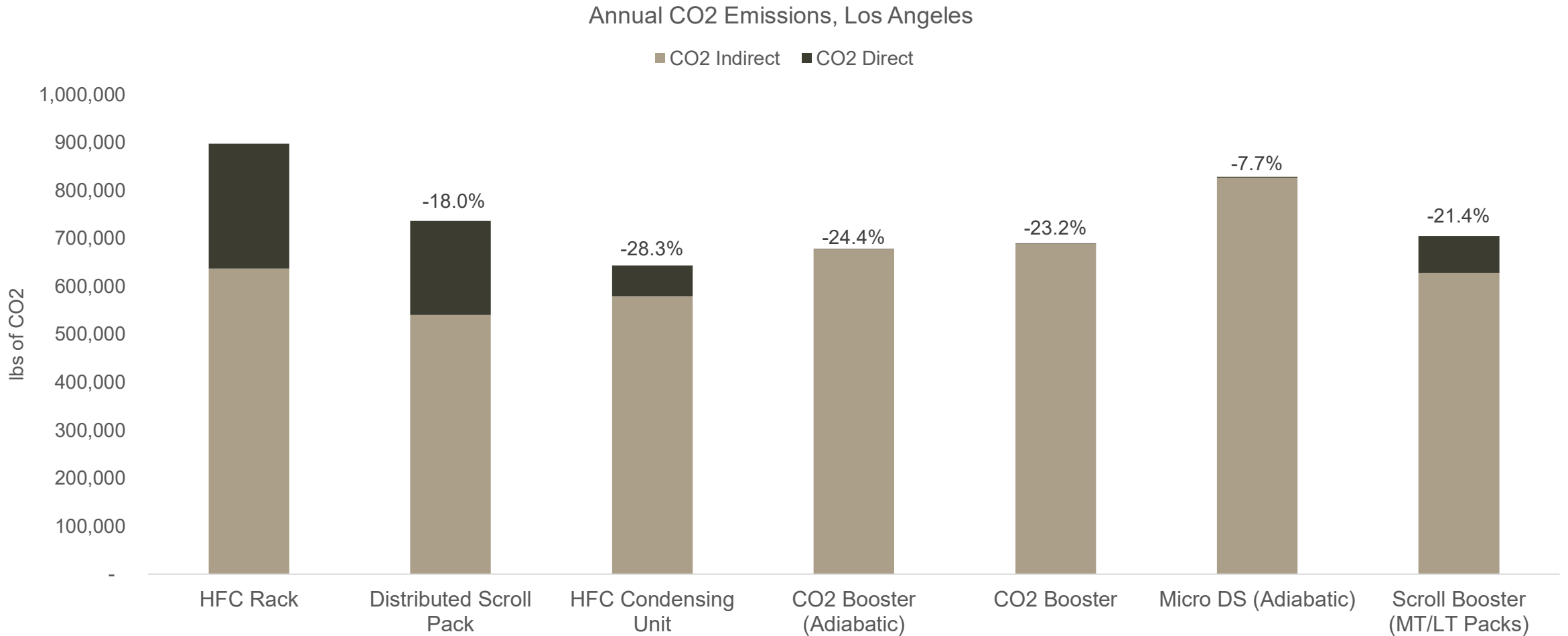

Los Angeles First Cost vs Total Cost Comparison

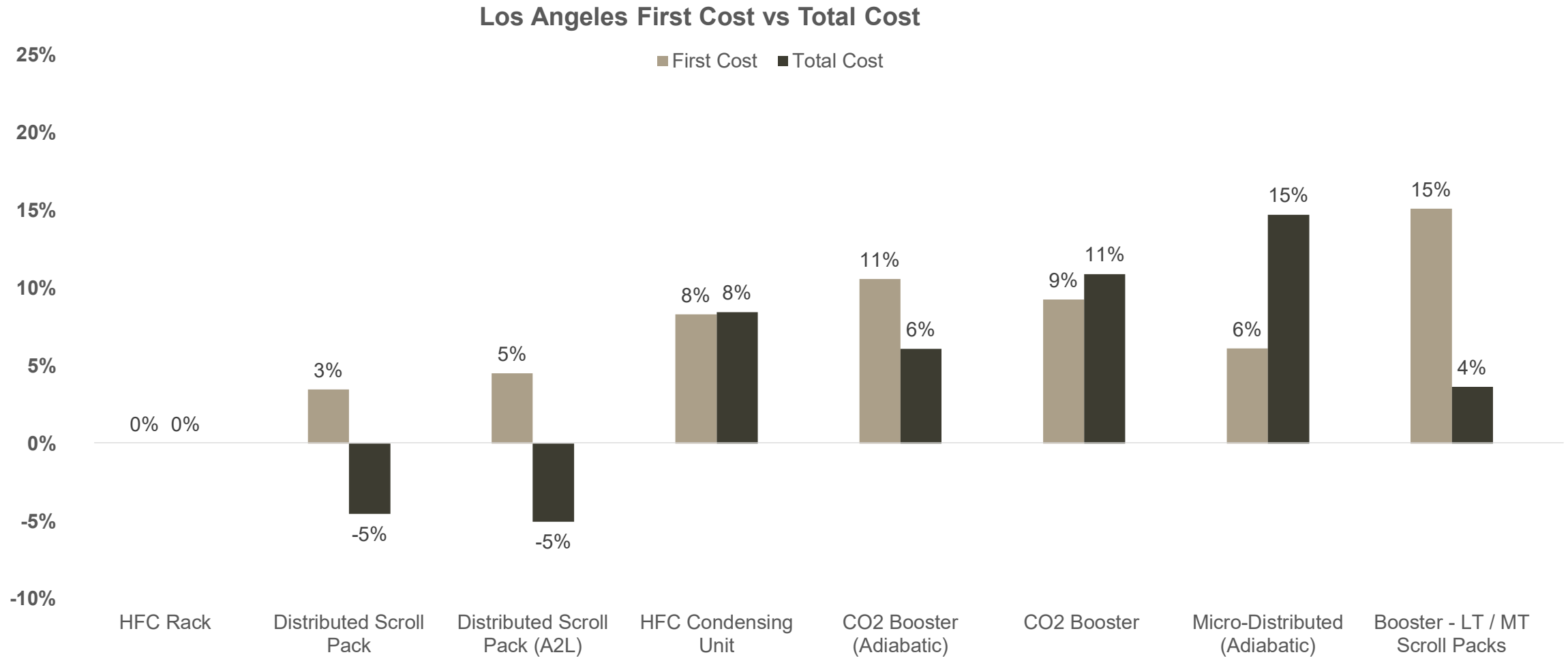

Los Angeles

Total Cost of Ownership, Los Angeles

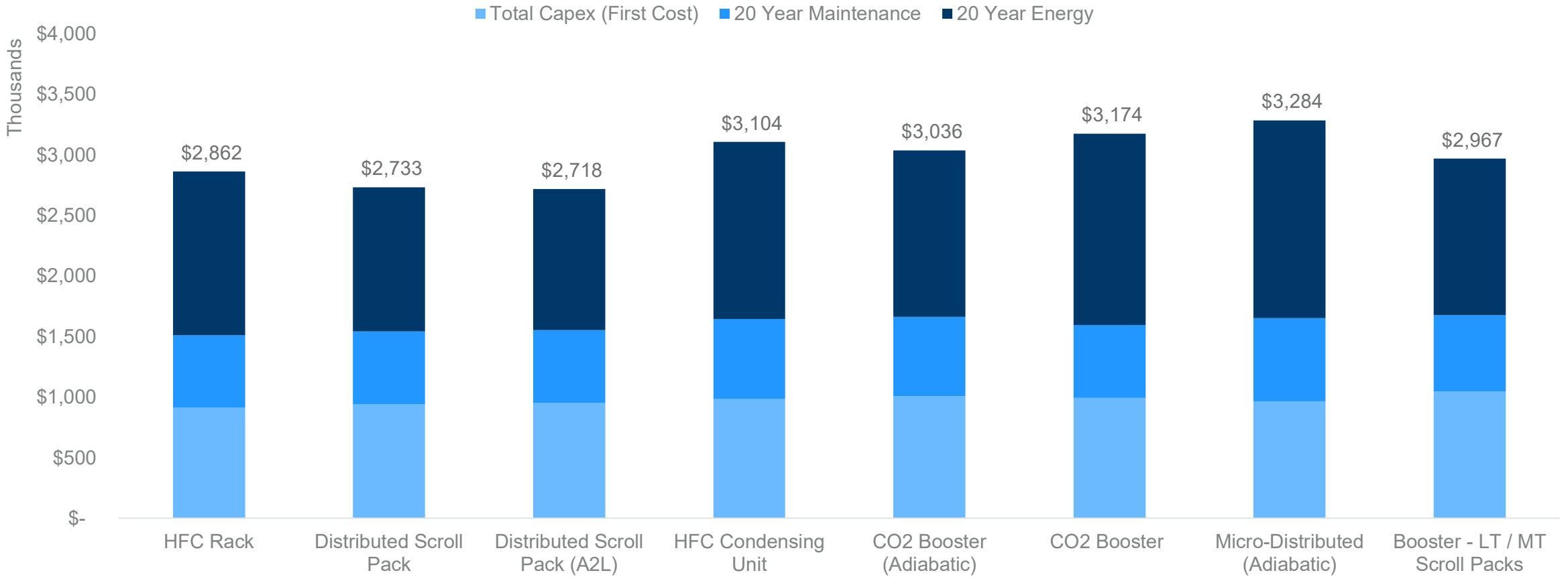

Explore Another Location

Continue To End of Section

Summary: Los Angeles



	HFC Rack	Distributed Scroll Pack	Distributed Scroll Pack (A2L)	HFC Condensing Unit	CO2 Booster (Adiabatic)	CO2 Booster	Micro-Distributed (Adiabatic)	Booster - LT / MT Scroll Packs
Energy	Very Good	Excellent	Excellent	Good	Good	Good	Poor	Good
Peak Power	Very Good	Excellent	Excellent	Fair	Excellent	Poor	Good	Excellent
First Cost	-	+3%	+5%	+8%	+11%	+9%	+6%	+15%
Total Cost	-	-5%	-5%	+8%	+6%	+11%	+15%	+4%
Emissions	Poor	Very Good	Very Good	Good	Excellent	Excellent	Fair	Very Good

Bakersfield



Bakersfield Energy Comparison

Annual Energy vs Peak Power, Bakersfield

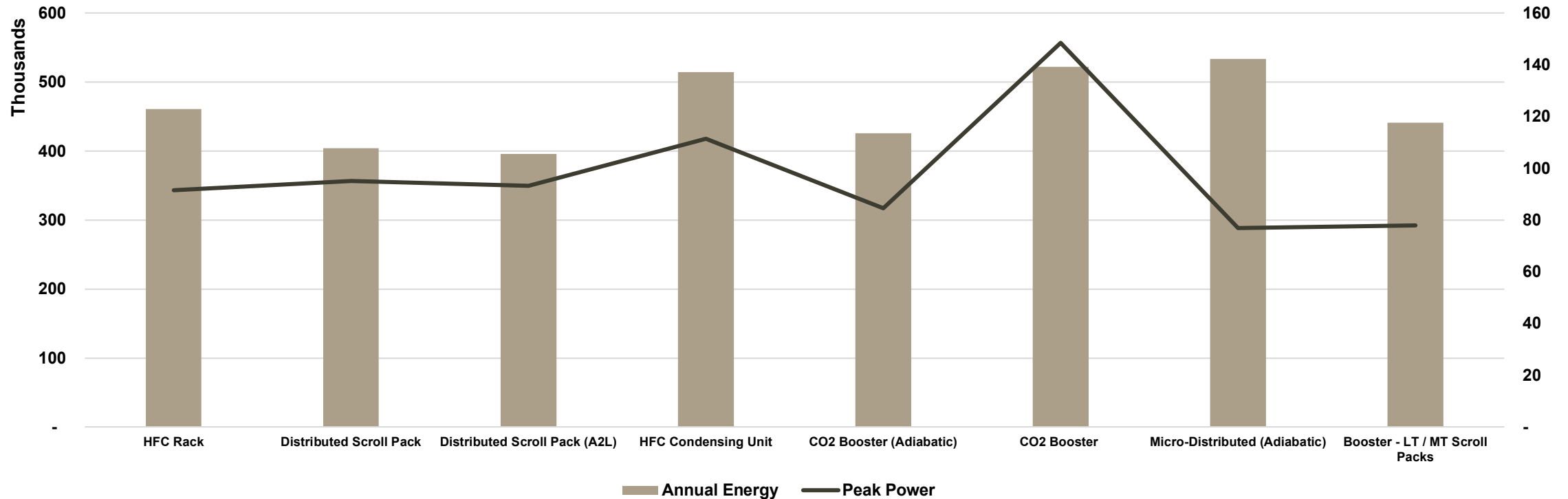

	HFC Rack	Distributed Scroll Pack	HFC Condensing	CO2 Booster (Adiabatic)	CO2 Booster	Micro-Distributed (Adiabatic)	Booster - LT / MT Scroll Packs
Annual Energy (Bakersfield)	460,783	404,250	514,566	425,612	522,168	533,913	441,440
\$ Usage (Based on \$0.11/KWh)	\$ 50,686	\$ 44,467	\$ 56,602	\$ 46,817	\$ 57,439	\$ 58,730	\$ 48,558
Peak Power	92	95	112	85	149	77	78
Peak Power \$ (Based on \$25kW)	\$ 27,471	\$ 28,518	\$ 33,451	\$ 25,353	\$ 44,561	\$ 23,055	\$ 23,396
Annual Total	\$ 78,157	\$ 72,985	\$ 90,053	\$ 72,170	\$ 102,000	\$ 81,785	\$ 71,955



Notes: Condensing unit energy modeled based on 20°F TD (MT and LT) with min 70° F SCT and 40° F superheat
Cycling losses not included in energy comparisons. Energy assessment based on constant load.

Bakersfield Annualized CO2 Emissions

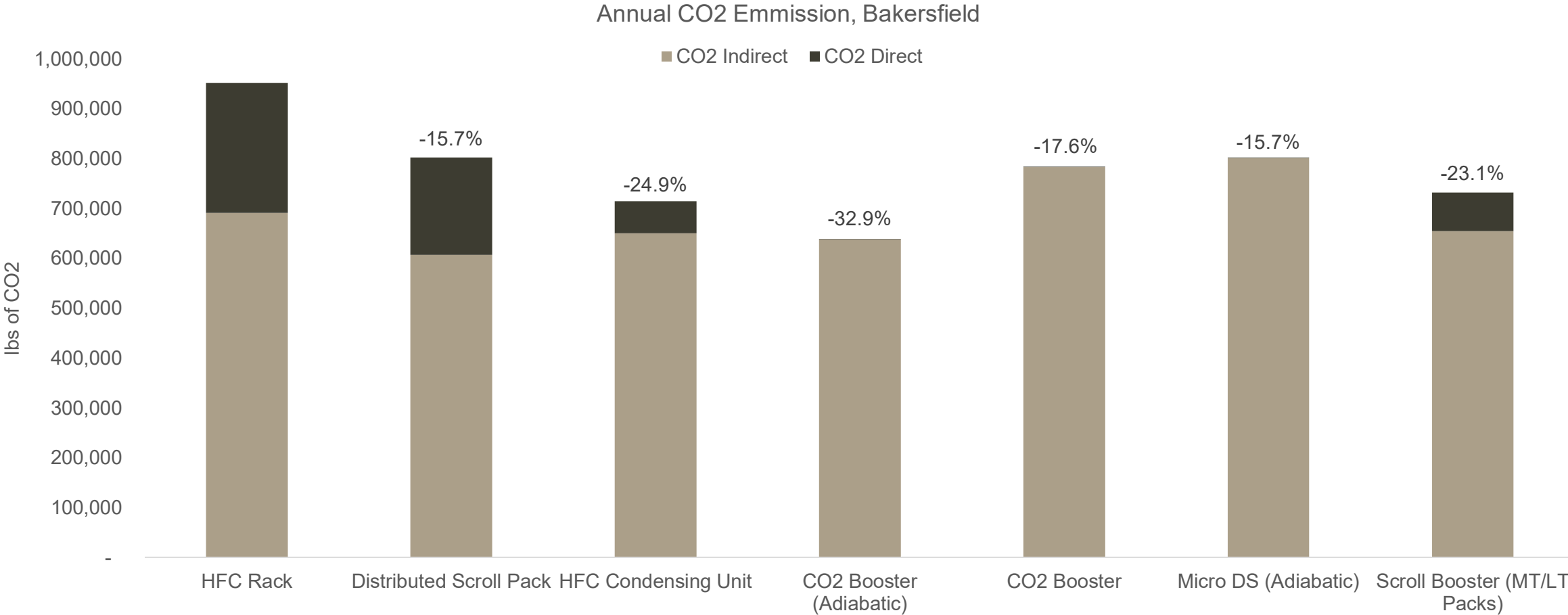

Bakersfield First Cost vs Total Cost Comparison

Bakersfield First Cost Vs Total Cost

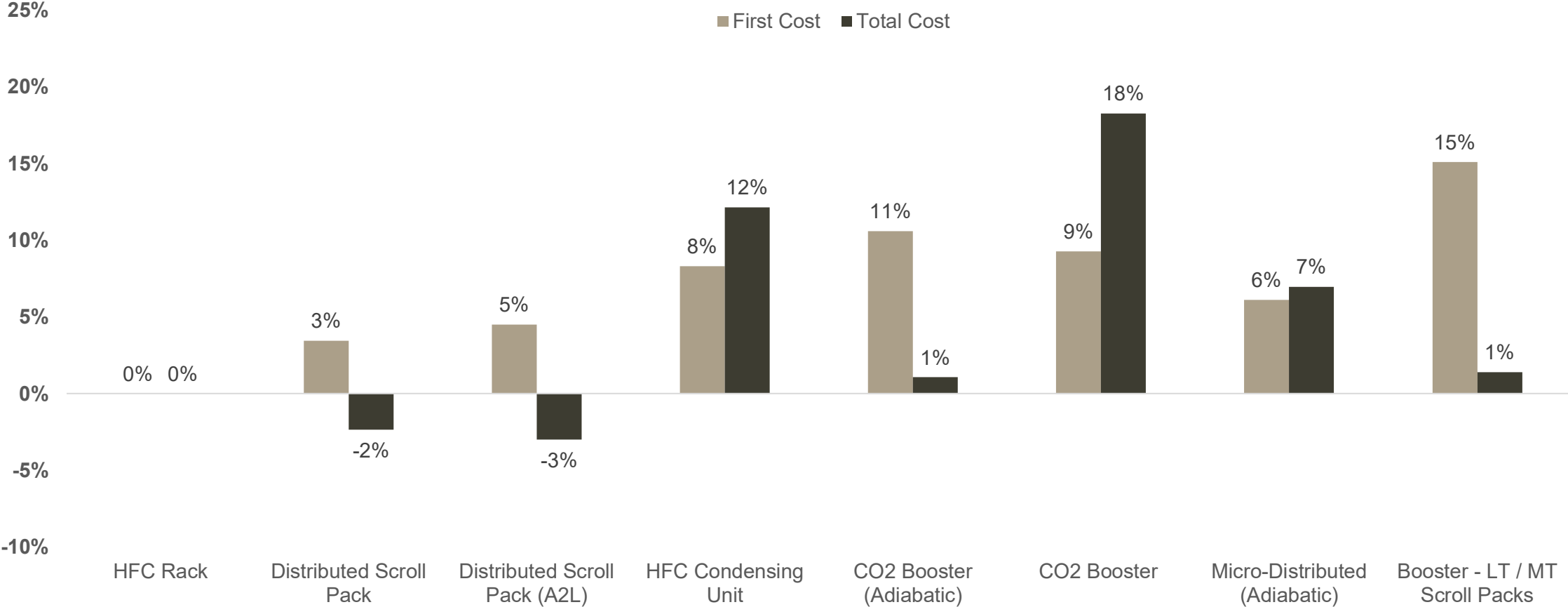

Bakersfield

Total Cost of Ownership, Bakersfield

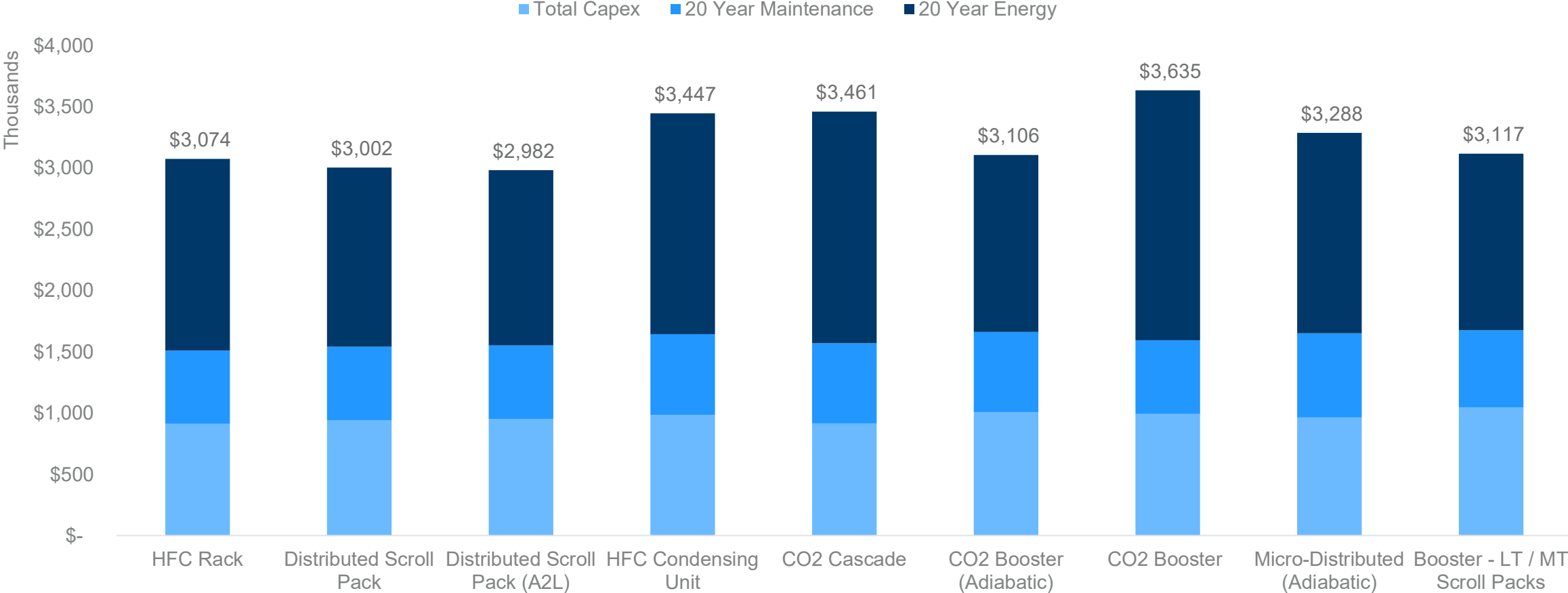

Explore Another Location

Continue To End of Section

Summary: Bakersfield



	HFC Rack	Distributed Scroll Pack	Distributed Scroll Pack (A2L)	HFC Condensing Unit	CO2 Booster (Adiabatic)	CO2 Booster	Micro-Distributed (Adiabatic)	Booster - LT / MT Scroll Packs
Energy	Very Good	Excellent	Excellent	Fair	Excellent	Fair	Fair	Very Good
Peak Power	Very Good	Very Good	Very Good	Good	Excellent	Poor	Excellent	Excellent
First Cost	-	+3%	+5%	+8%	+11%	+9%	+6%	+15%
Total Cost	-	-2%	-3%	+12%	+1%	+18%	+7%	+1%
Emissions	Poor	Good	Very Good	Good	Excellent	Good	Good	Very Good

Minneapolis



Minneapolis Energy Comparison

Annual Energy vs Peak Power, Minneapolis

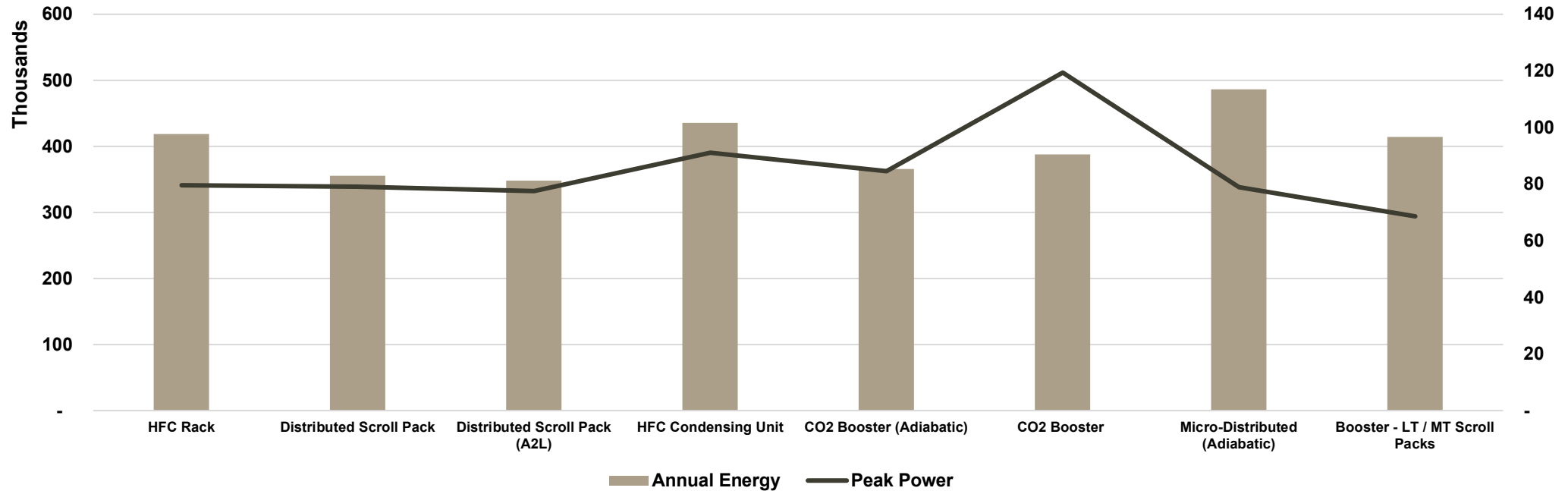

	HFC Rack	Distributed Scroll Pack	HFC Condensing Unit	CO2 Booster (Adiabatic)	CO2 Booster	Micro DS (Adiabatic)	Booster - LT / MT Scroll Packs
Annual Energy (Minneapolis)	418,911	355,372	363,945	365,774	387,974	486,319	414,649
\$ Usage (Based on \$.09/K/Wh)	\$ 37,702	\$ 31,983	\$ 32,755	\$ 32,920	\$ 34,918	\$ 43,769	\$ 37,318
Peak Power	80	79	91	85	119.4	79	69
Peak Power \$ (Based on \$10.02kW)	\$ 9,570	\$ 9,515	\$ 10,956	\$ 10,161	\$ 14,360	\$ 9,492	\$ 8,257
Annual Total	\$ 47,272	\$ 41,498	\$ 43,711	\$ 43,081	\$ 49,278	\$ 53,261	\$ 45,575

Minneapolis Annualized CO2 Emissions

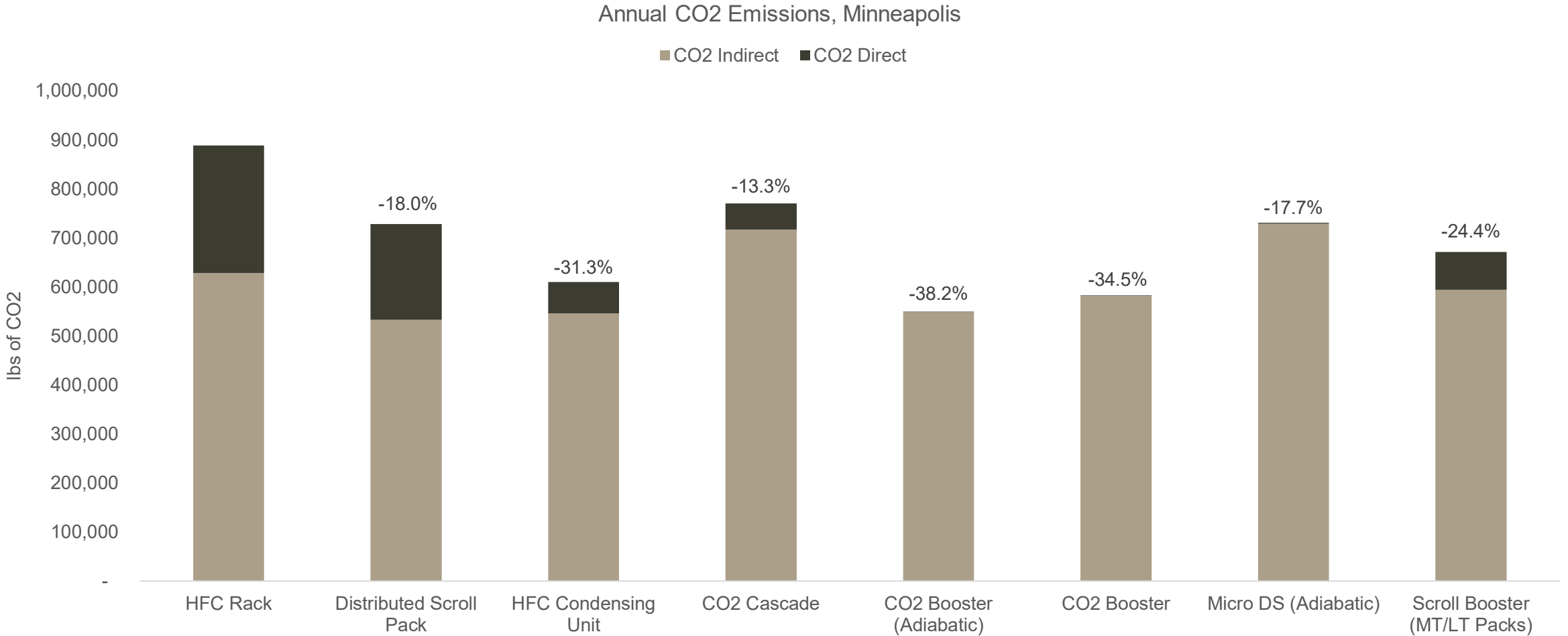

Minneapolis First Cost vs Total Cost Comparison

Minneapolis First Cost Vs Total Cost

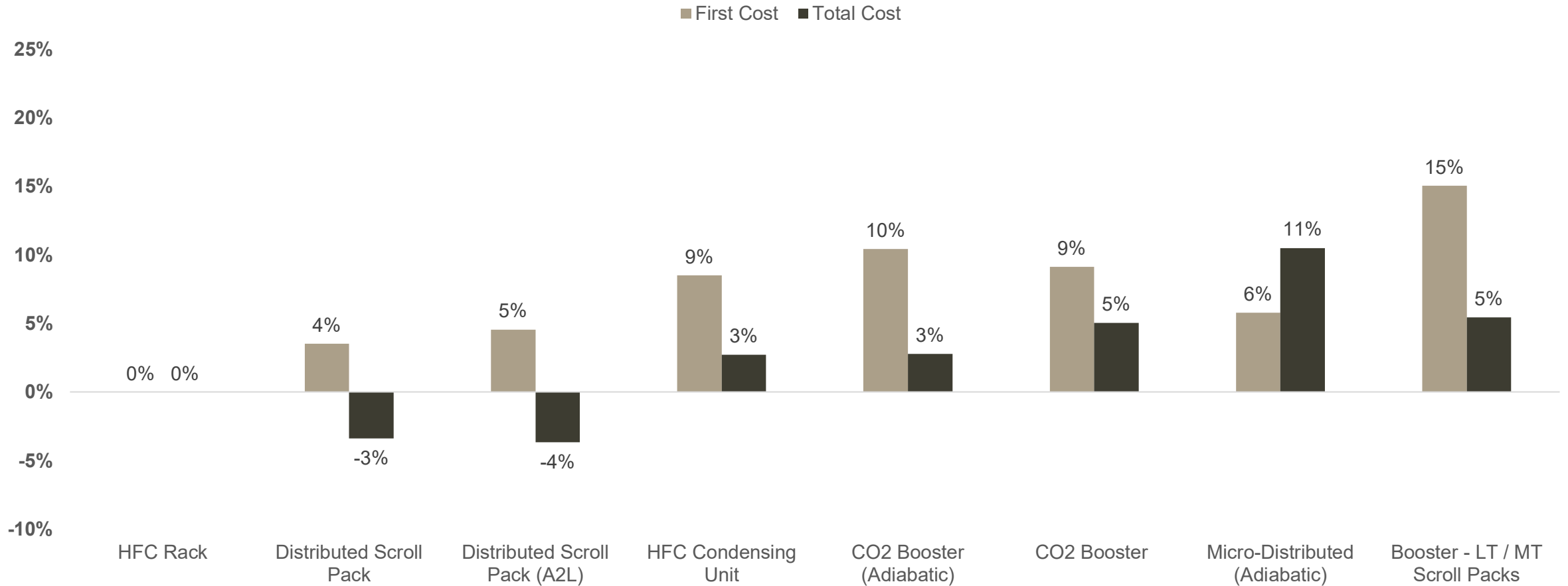

Minneapolis

Total Cost of Ownership, Minneapolis

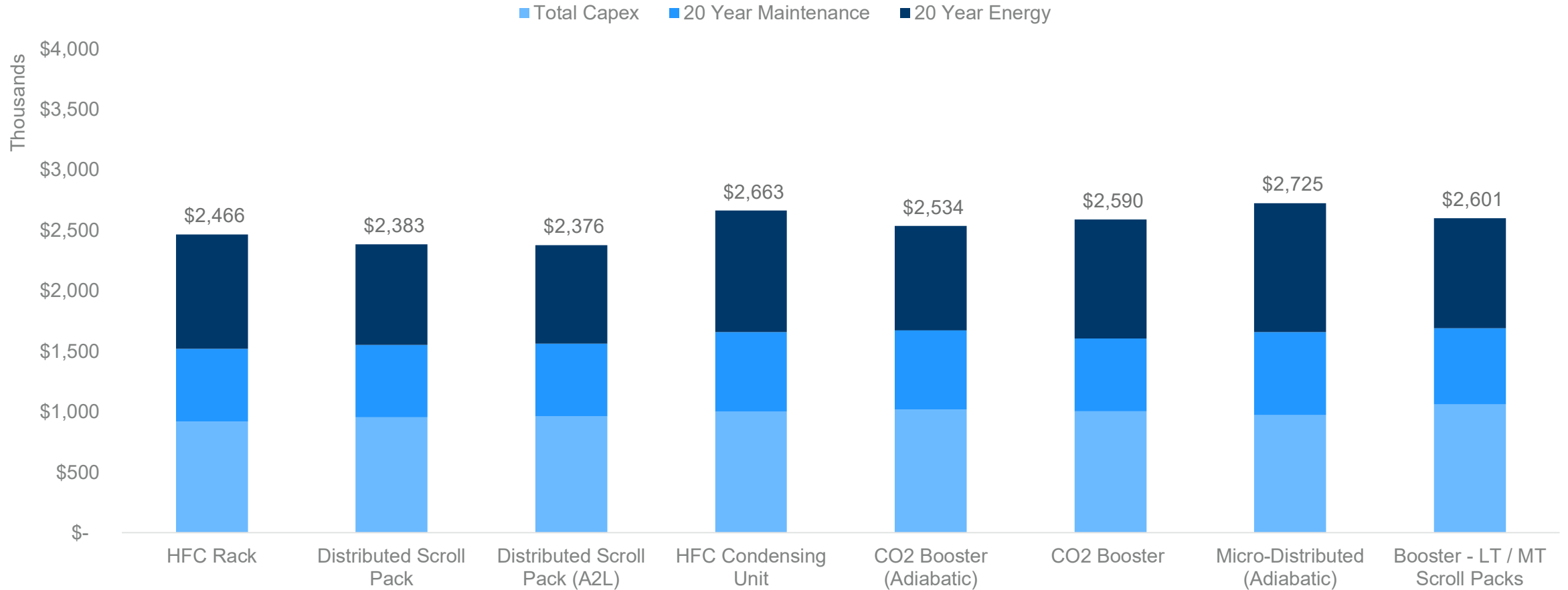

Explore Another Location

Continue To End of Section

Summary: Minneapolis



	HFC Rack	Distributed Scroll Pack	Distributed Scroll Pack (A2L)	HFC Condensing Unit	CO2 Booster (Adiabatic)	CO2 Booster	Micro-Distributed (Adiabatic)	Booster - LT / MT Scroll Packs
Energy	Good	Excellent	Excellent	Good	Excellent	Very Good	Poor	Good
Peak Power	Very Good	Very Good	Excellent	Good	Very Good	Poor	Very Good	Excellent
First Cost	--	+4%	+5%	+9%	+10%	+9%	+6%	+15%
Total Cost	--	-3%	-4%	+3%	+3%	+5%	+11%	+5%
Emissions	Poor	Good	Very Good	Excellent	Excellent	Excellent	Good	Very Good

Dayton



Dayton Energy Comparison

Annual Energy vs Peak Power, Dayton

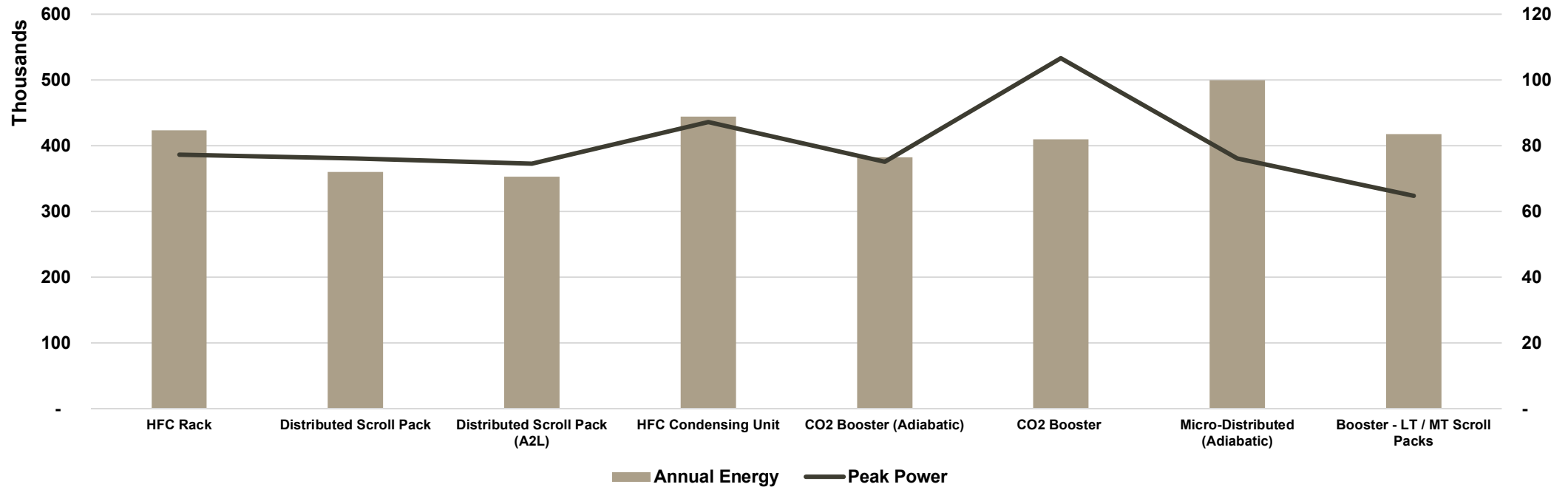

	Centralized Racks	Distributed Scroll Pack	Condensing Units	CO2 Booster (Adiabatic)	CO2 Booster	Micro DS (Adiabatic)	Booster - LT / MT Scroll Packs
Annual Energy (Dayton)	423,343	360,407	372,353	382,719	409,716	499,678	417,508
\$ Usage Based on \$.05/KWh.	\$ 21,167	\$ 18,020	\$ 18,618	\$ 19,136	\$ 20,486	\$ 24,984	\$ 20,875
Peak Power	77.2	76.1	87.3	75.1	106.6	76.1	64.7
Peak Energy \$ (Based on \$2.03K/W)	\$ 1,882	\$ 1,853	\$ 2,126	\$ 1,830	\$ 2,597	\$ 1,853	\$ 1,577
Annual Total	\$ 23,049	\$ 19,874	\$ 20,743	\$ 20,966	\$ 23,083	\$ 26,837	\$ 22,453

Dayton Annualized CO2 Emissions

Annual CO2 Emmission, Dayton

■ CO2 Indirect ■ CO2 Direct

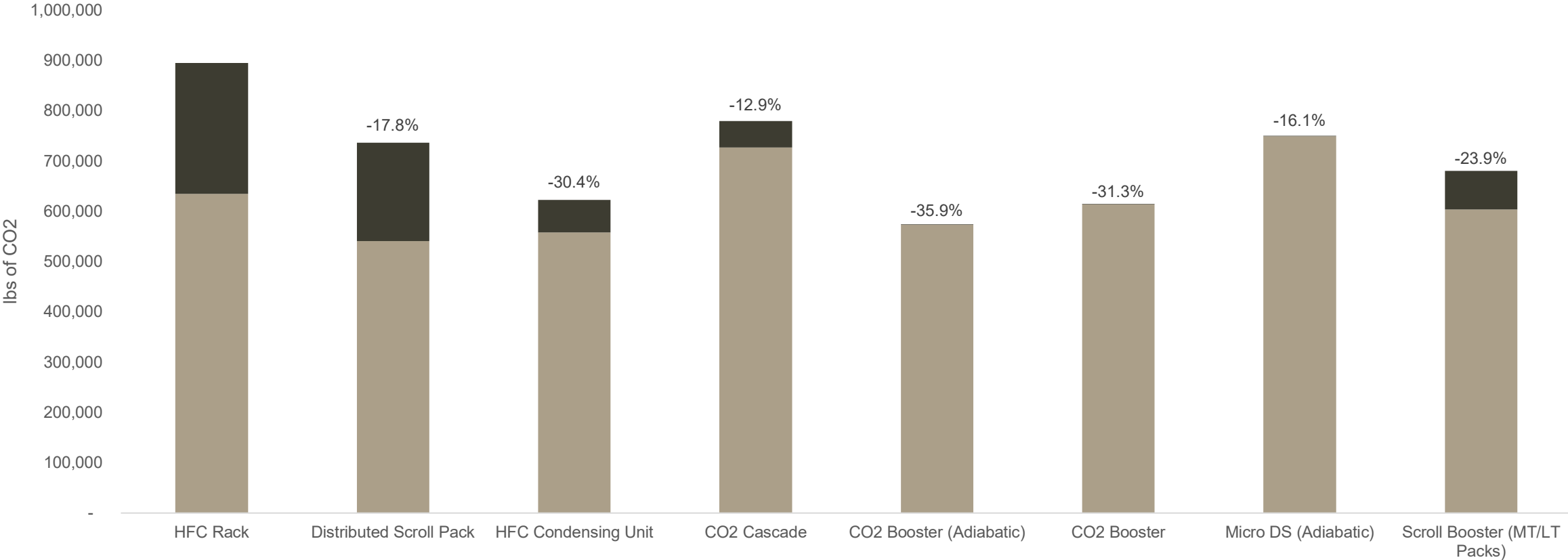

Dayton First Cost vs Total Cost Comparison

Dayton First Cost Vs Total Cost

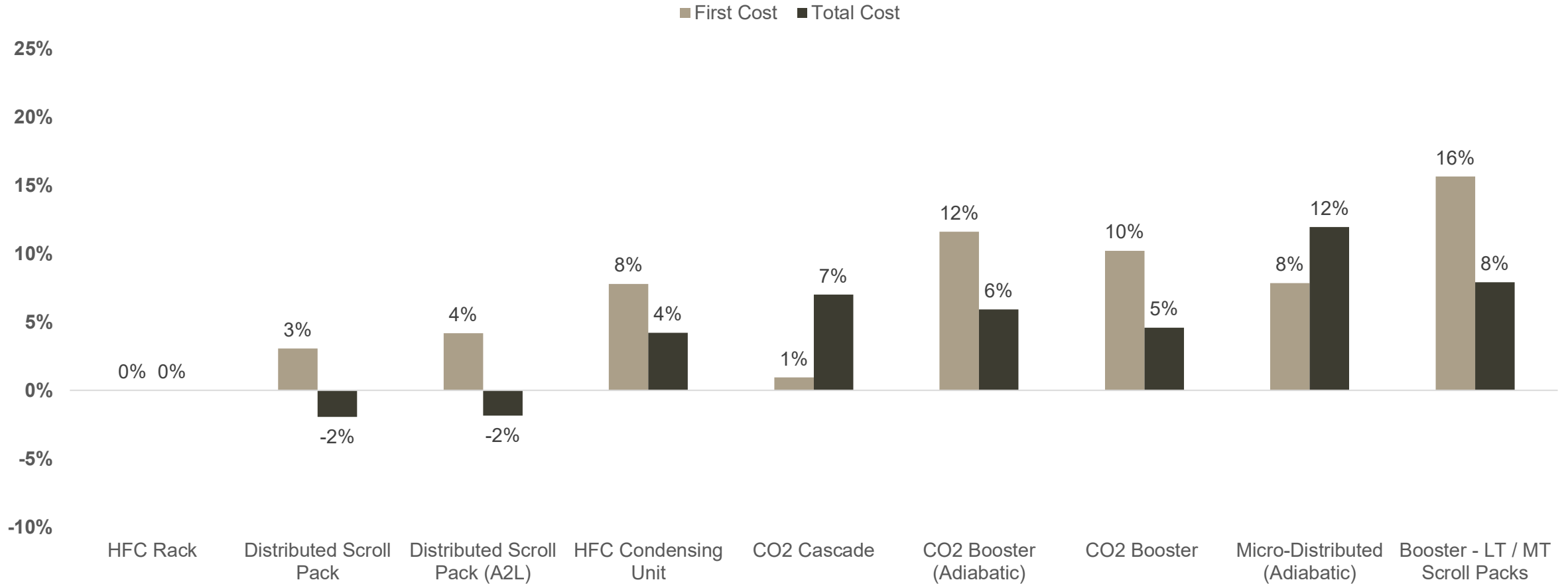

Dayton

Total Cost of Ownership, Dayton

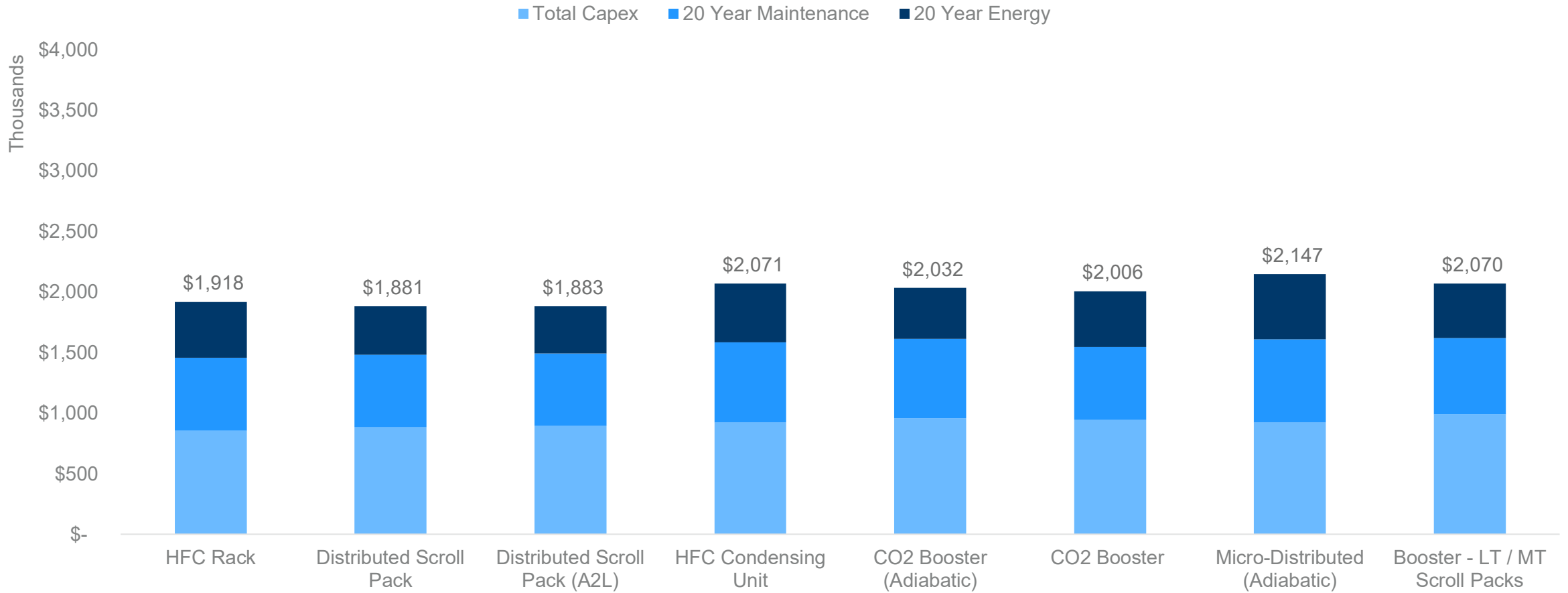

Explore Another Location

Continue To End of Section

Summary: Dayton



	HFC Rack	Distributed Scroll Pack	Distributed Scroll Pack (A2L)	HFC Condensing Unit	CO2 Booster (Adiabatic)	CO2 Booster	Micro-Distributed (Adiabatic)	Booster - LT / MT Scroll Packs
Annual Energy	Good	Excellent	Excellent	Excellent	Excellent	Very Good	Poor	Good
Peak Power	Very Good	Very Good	Very Good	Good	Very Good	Poor	Very Good	Excellent
First Cost	--	3%	4%	8%	12%	10%	8%	16%
Total Cost	--	-2%	-2%	4%	6%	5%	12%	8%
Emissions	Poor	Good	Very Good	Excellent	Excellent	Excellent	Good	Very Good

Additional Considerations



Electrical rate

Rate Structure, Peak Demand Charges



Water resources

Availability, Cost, Sewage Charges



Service & maintenance skill level

Regional CO₂ experience or knowledge gap



Heat Reclaim

Volume and Intensity Requirements



Fossil fuel charges



Carbon Intensity, Electrical Generation Sources

Impact on Net-Zero 2040 Goals for Scope 2 Emissions

Summary

This study was commissioned to provide industry stakeholders with an unbiased 3rd party engineering evaluation of system comparison of the most common architectures to support low GWP System Transitions for the Refrigeration industry

Additional Industry Support Tools

Mechanical Subcooling on CO₂ System

- 3rd Party Engineering Study
- Evaluated net energy saving potential of various strategies used for to reduce Gas Cooler CO₂ fluid temperature

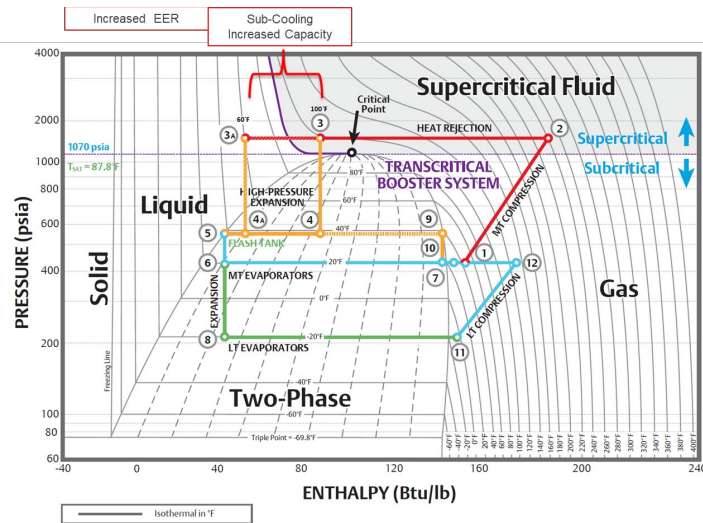

Ultra Low Superheat Study; CO₂

- 3rd Party Engineering Study
- Evaluated energy saving potential
 - 50 Units Coolers (Max/Min/Ave delta T)
 - 254 Display cases (Max/Min/Ave delta T)
- All followed North American Standards: AWEF, NRCan, Energy Star.
- Compared 10 SH Coils to;
 - Ultra-low to Zero SH
 - Liquid Ejectors
 - Other OEM specific low SH Strategies
 - Flooded Coils

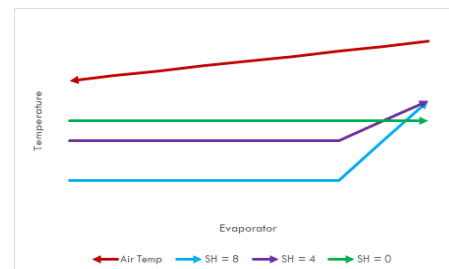

CO₂ Stewardship

- E-book



- Video Series (20)



- Article Series, Blogs, Ect..
- White Papers, A2L and CO₂
- E360 Webinars

COPELAND

Copeland ESG



We commit to reaching
Science-Based Aligned
Net Zero
GHG Emissions
across all Scopes (1, 2 & 3)
by **2045**
from 2021

To get us on the
right pathway by **2030**

we commit to achieving...

1.5°C Aligned

Net Zero
Operations

Scopes 1 & 2 GHG Emissions

25% **Absolute**
Reduction

Scope 3 GHG Emissions

Source

100%

Renewable Electricity

in our offices and facilities

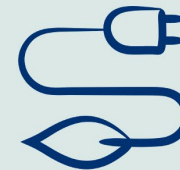

Reduce

25%

our **Energy**
Intensity

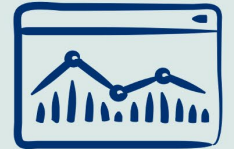

COPELAND

EMERSON

Our journey so far...

In 2019, Emerson/Copeland committed to reduce GHG emissions by **20%** normalized to sales by 2028 from 2018

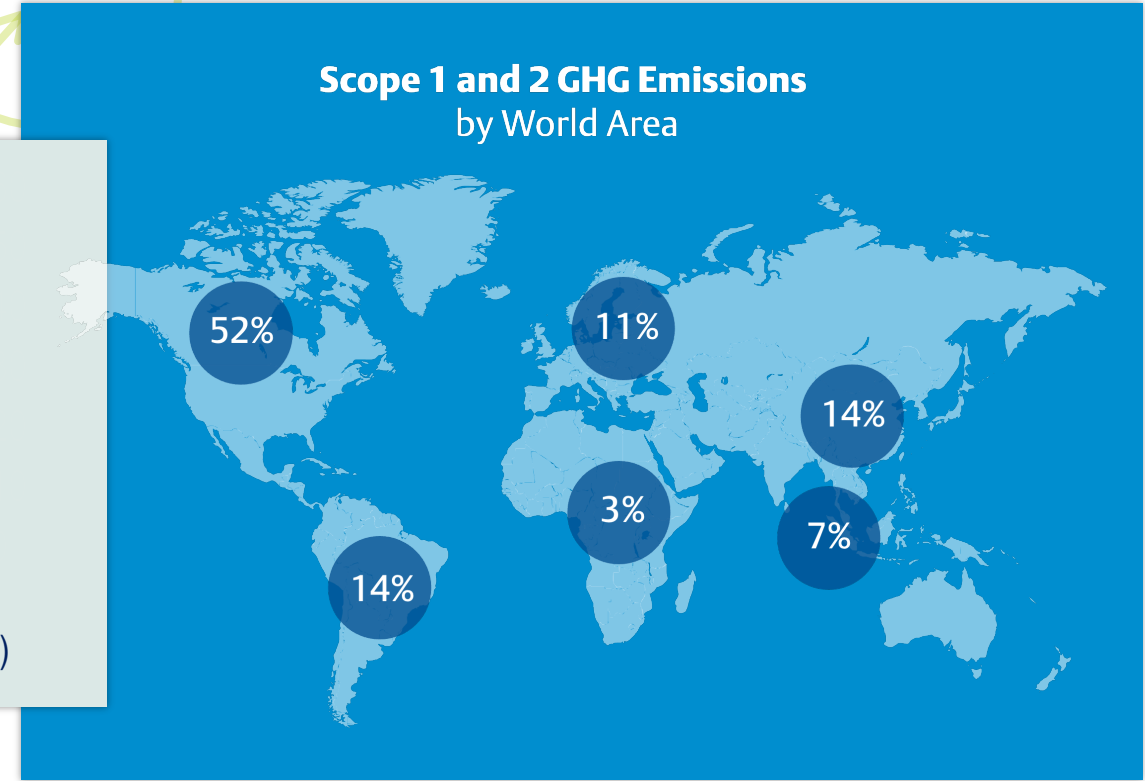
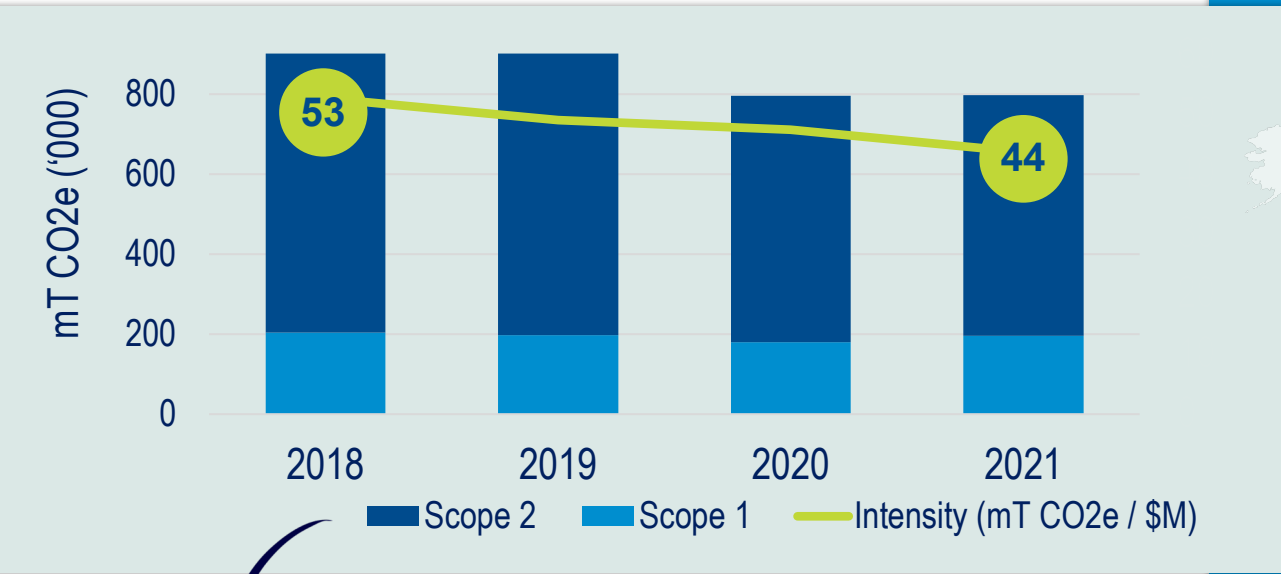

Scope 1 & 2 Emissions Intensity

↓42%
from 2018



Energy Intensity (MWh/\$)

Reduced by **↓19%**
from 2018

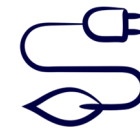

Percentage Renewable Electricity

30%
World Wide

Beyond our four walls, we have a huge opportunity to influence change in our value chain

Total Scope 3 GHG Emissions
~591,400,000 mTCO₂e

Copeland's Scope 3 Emissions

99%
from the Use of Our Products

~
South Korea's
annual emissions

Running on electricity for
+15 years

COPELAND



Heating, cooling & refrigerating



Controlling & optimizing operations

WHERE DO THE REST OF OUR EMISSIONS COME FROM?



From the materials, components & capital goods that we purchase

2,049,500 mTCO₂e



From the transportation & distribution of our products

803,000 mTCO₂e



From the daily commute of Emerson employees

155,000 mTCO₂e



From the disposal or recycling of our products

150,000 mTCO₂e



Net Zero Operations — 2030 Roadmap

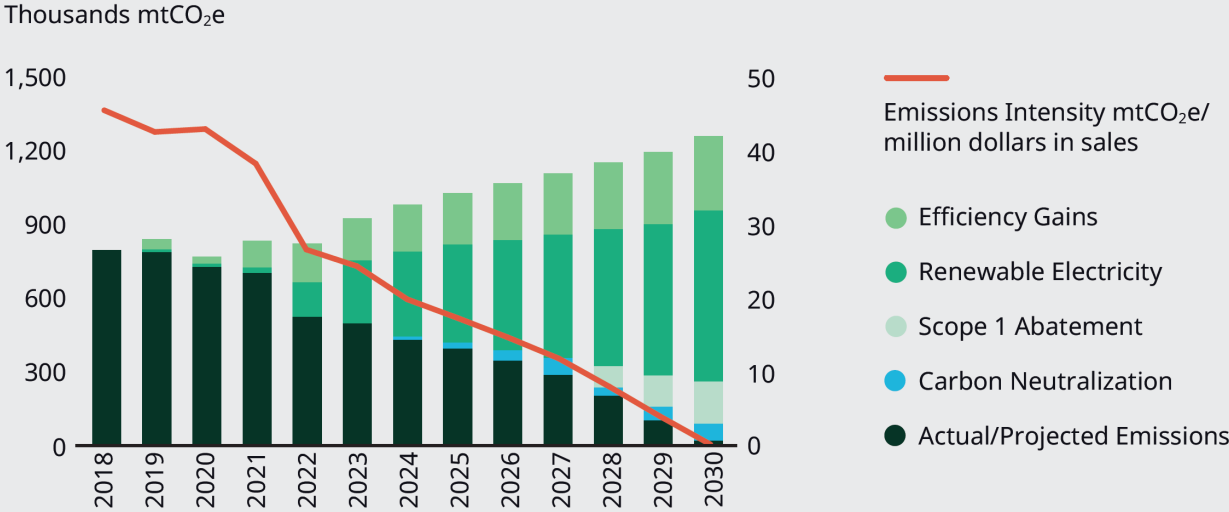

Emission and intensity calculations include data from all Emerson manufacturing and non-manufacturing facilities worldwide. Data from 2018-2022 represents actual emissions, and data for 2023 and beyond are estimates.

Progress on Emissions Intensity Target Since 2018

53%

Energy Efficiency Gain Examples

- Energy Treasure Hunts
- Compressed Air Optimization
- HVAC Setback
- Footprint Consolidation
- Equipment Shutdown
- LED Lighting

22%

Renewable Electricity



25%

Grid Decarbonization*



*Grid emission factors represent computed, weighted average values accounting for Emerson's geographical mix of global electricity consumption in each year. The International Energy Agency (IEA) emission factors are generally used, with more granular, regional factors also employed in certain cases (e.g. eGRID factors in the United States).

Net Zero Operations — 2030 Roadmap

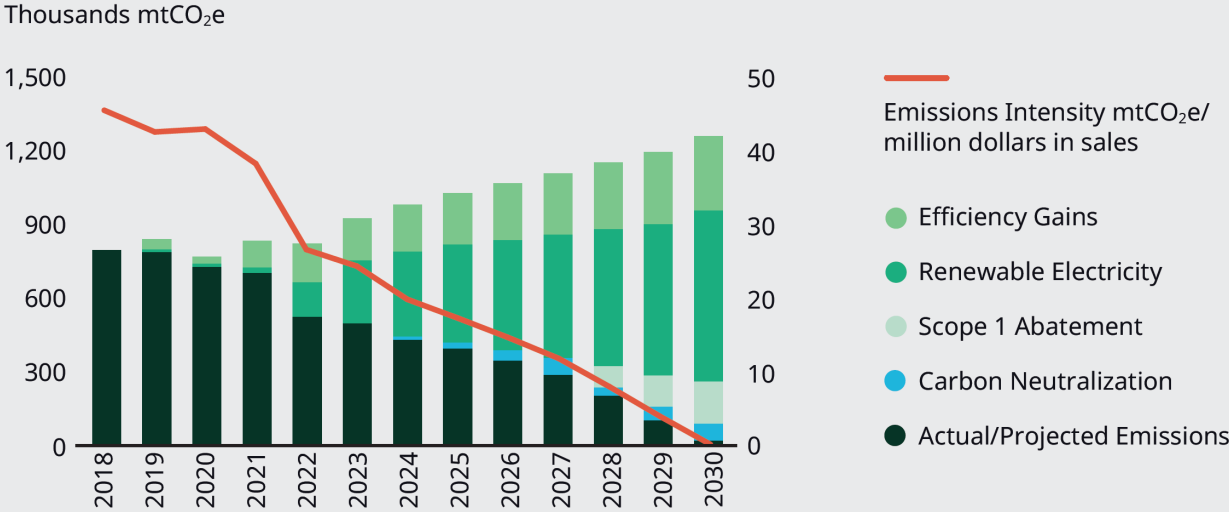

Emission and intensity calculations include data from all Emerson manufacturing and non-manufacturing facilities worldwide. Data from 2018-2022 represents actual emissions, and data for 2023 and beyond are estimates.

Energy Efficiency Project Examples

Below are several examples of energy reduction projects driving noteworthy savings across world areas.

LED LIGHTING RETROFIT



67
MWh saved

Actuation Technologies, Italy



TIMERS TO SHUT DOWN PROCESS EQUIPMENT



500
MWh saved

Measurement & Analytical, Mexico



DESK PHONE REMOVAL



82
MWh saved

Corporate Shared Services, Philippines



Emerson/Copeland is highly relevant in a lower carbon future

Four Major Strategies for Environmental Sustainability

ENERGY SOURCE DECARBONIZATION



Low-carbon Power
(Solar, Wind, Nuclear,
Hydro)



Low-carbon Fuels
(Biofuels, LNG)



Hydrogen &
Hydrogen-based
Fuels

ELECTRIFICATION & SYSTEM INTEGRATION



End-use
Electrification
(Heat Pumps)



Energy Supply
Optimization



Energy Storage &
Grid Management

ENERGY EFFICIENCY & OPTIMIZATION



Advanced Controls
& Analytics



Simulation
& Remote Monitoring



Waste
Management

EMISSIONS MANAGEMENT



Emissions
Monitoring
& Control



Carbon Capture
Utilization
& Storage



Natural & Low
GWP Refrigerants

Report At-A-Glance

Environment

Net Zero Value Chain
emissions by 2045 from a
2021 baseline

Achieved our goal of decreasing
emissions intensity 20% from
2018, **6 years ahead
of schedule**

Net Zero Operations
by 2030 from a 2021 baseline

Reduced Scope 1 and 2
GHG emissions intensity by
42% since 2018

Near-term and net zero
targets have been
approved by the
**Science Based Targets
initiative (SBTi)***

30% of electricity procured
from renewable sources at
Emerson locations worldwide

Announced new waste target
Zero Waste to Landfill
by 2032 from a fiscal
2022 baseline

Social

40% of global leadership
targeted to be women and
30% of U.S. leadership
targeted to be minorities by 2030

Employee Resource Groups
have grown to
over 13,000 members

Initiated company-wide
continuous listening
strategy with 85% employee
participation and an employee
engagement score of 78%*

\$200M pledged to address
education equity over 10 years

Launched Emerson's Employee
Value Proposition: **Let's Go***

Governance

ESG targets integrated
in compensation programs
for leadership

46% of Directors are women
or persons of color*

Introduced a new
**Technology and
Environmental
Sustainability**
Board committee*

40% decrease in total
recordable rate of injuries
since 2018



Peter Zornio
Appointed Chief
Technology Officer,
November 2022



**Mike
Baughman**
Appointed Chief
Financial Officer,
May 2023



Vidya Ramnath
Appointed Chief
Marketing Officer,
June 2023

*Great Smoky Mountains
National Park, U.S.
Photo By:
Jesse Renfroe
Emerson Employee*

*Depicts data/information as of June 2023.

Building an Effective Controls Transition Plan in your Food Retail Operation



What Does Copeland Supervisory Control System Do?

New Store

Remodel



Refrigeration



Lighting



HVAC



Energy Monitoring



- Built In Display
- Communicates to Modbus, BACnet Devices
- Multiple Ethernet Ports
- Onboard Graphics



- Cost flexibility
- Ideal for space constrained areas
- Flexible display options
 - Onboard I/O
- Flexible mounting

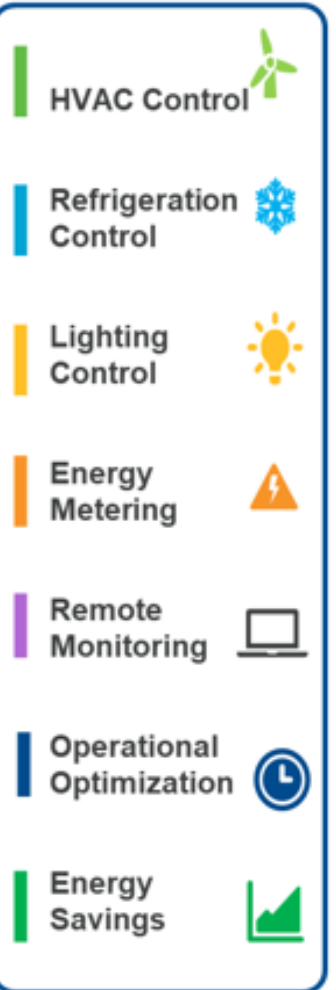

COPELAND

Touch Screen's 10, 15, 21 Inch Models Available

2. Optional Touch Screen and Sizes Available



Wall-Mounted Control Screen and Interface

- Optional Sizes/Price point and user experience
- Primary access for local-level users
- Touchscreen color display
- Icon- and menu-driven operation
- Intuitive functions are familiar to all; no special training required
- View-only default
- Password protected access to advanced functions for managers and technician user modes
- Access to advanced functions requires authorization

Network Architecture

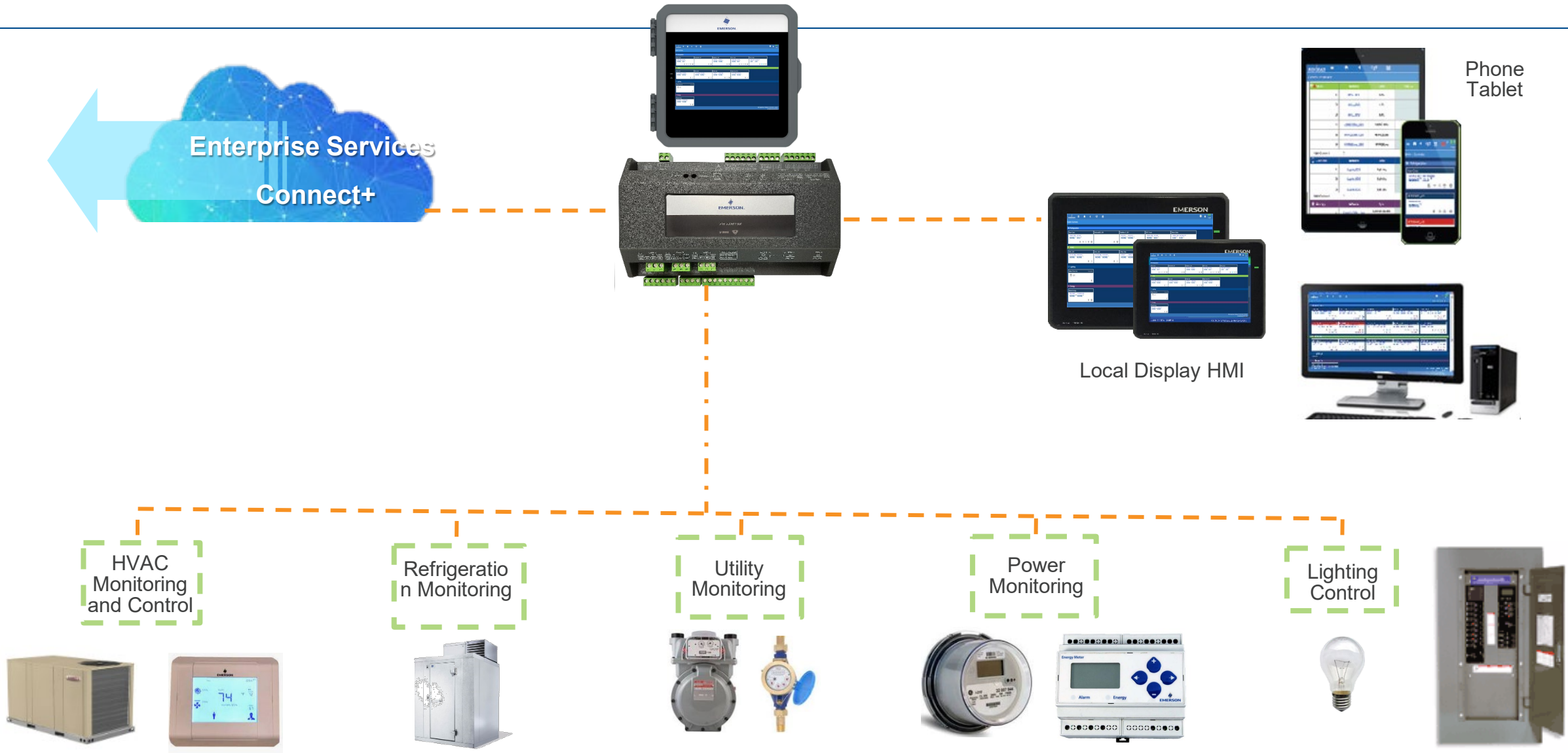

Network Layout _ Flexibility with Existing and New Controllers

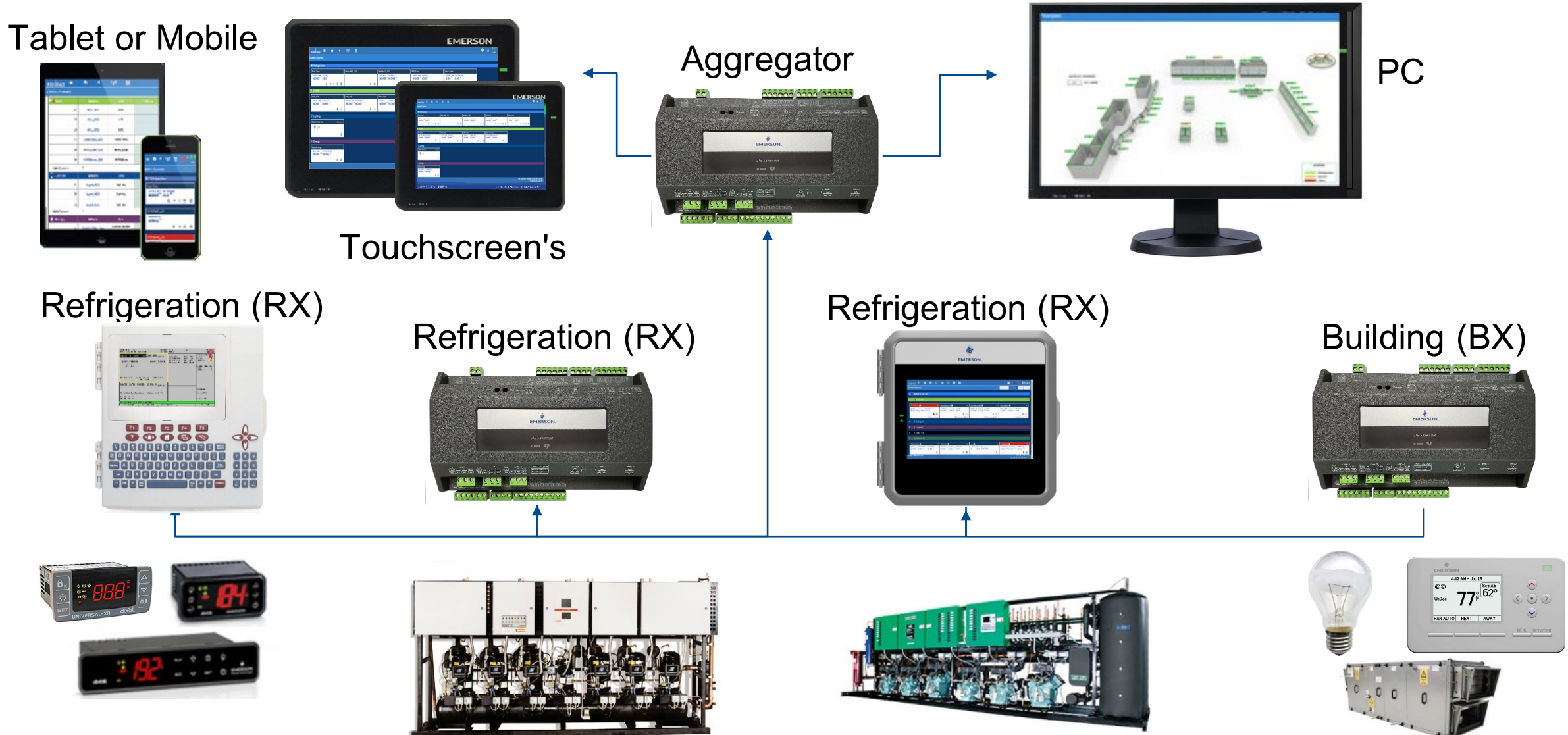

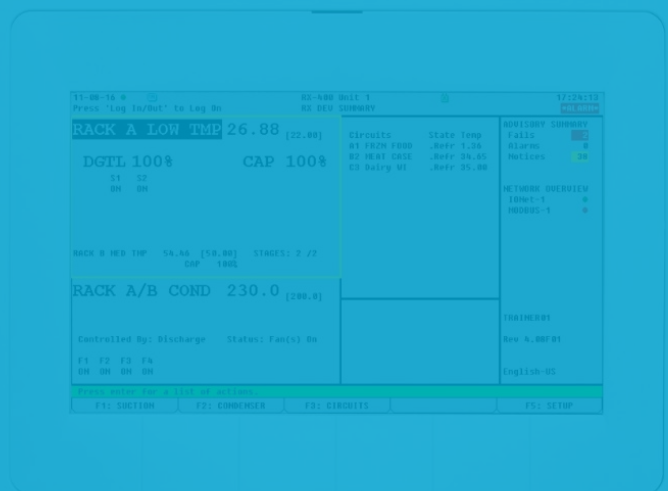

E3 vs E2e

Introduction to the Platform

E3 vs E2

E3 front view



E2e front view



E3 vs E2

E3 software: Supervisory Control Software

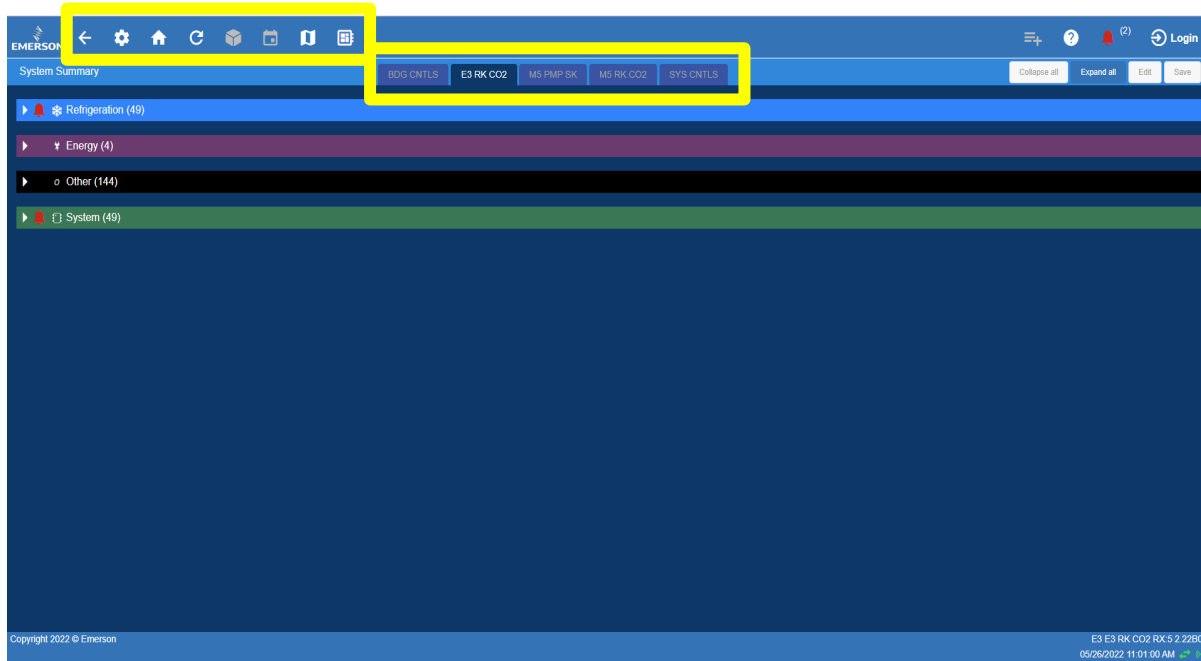

E2 Software:

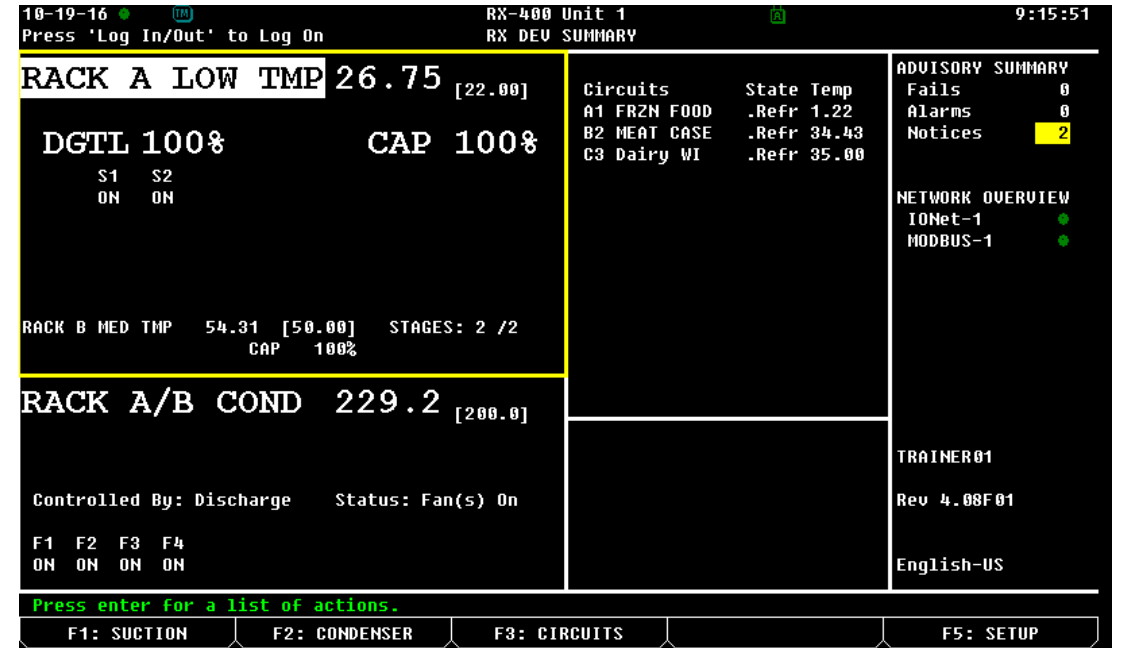

The E3 operates on a shared software platform with Site Supervisor. This new format offers intuitive navigation that technicians will find familiar and easy to use.

E3 Controller is a Drop-in Replacement for the E2 Product



- **True E2 Drop-in Replacement**
 - Identical wiring holes, mounting points and vents
 - Enclosure fits into existing panel cut-out
- **Updated Integrated Display**
 - **Larger 10"** capacitive color touch-screen
 - User-friendly interface with on-screen keyboard
- **Equivalent COM Port Configuration and Power Connections**
 - **Total of four COM ports** for connected devices with two isolated COM ports
 - Easily swap out an E2 with no need for rewiring
- **Fully Backward Compatible With MultiFlex and IONet Boards**

E3 Technical Specifications

Operating Temperature	-40°F to 149°F (-40°C to 65°C)
Operating Humidity	5% - 95% RH non-condensing at 90°F
Storage Humidity	5% - 100% RH
24 VAC	24 VAC ±20%, 50/60 Hz, Class 2, 80VA
Dimensions	12" L x 12.5" W x 3.75 H"
4 RS485 ports	COMM 1 = RS485 Com 2 A and B COMM 2 = RS485 Com 6 (isolated) COMM 3 = RS485 (isolated) COMM 4 = RS485 Com 4 A and B
2 Ethernet ports	Ports 0,1
2 USB ports	J2, J3

Hardware Enhancements and Modified Applications

Hardware Enhancements

E2 Hardware	E3 Hardware
500 MHz Single Core	1.6 GHz Quad Core
128 MB RAM	2 GB RAM
1 Ethernet Port (1 MAC/PHY)	2 Ethernet Ports (2 MAC/PHY)
3 RS-485 COM Ports	4 RS-485 COM Ports (2 Isolated)
Plug for Optional I/O Daughter Card	Plug for Optional I/O Daughter Card

Modified Applications in E3

E2 Application Name	New E3 Application Name
Eng. Unit Converter	Localization
Heat/Cool Control	Thermostat or Sensor Control
Power Monitoring	Utility Monitoring
Pulse Accumulator	Utility Monitoring
Time Schedule	Scheduler

Twelve times faster processing power and 16X additional memory built in to E3 and SS for faster response time and increased storage.

Model Cross Reference for Supervisory Control Platform (SS/E3) vs E2

E3 or Site Supervisor to E2 Cross-Reference Guide									
E2 Models	E3 / Site Supervisor Models								
	Small Format Controller SF	Refrigeration Controller RXS	Refrigeration Controller RXSe	Building Controller BXS	Building Controller BXSe	Combination Controller CXS	Combination Controller CXSe	Service Replacement SR	Site Aggregator SA
RX300		✓						✓	
RX400			✓					✓	
BX300				✓				✓	
BX400					✓			✓	
CX100	✓							✓	
CX300						✓		✓	
CX400						✓	✓	✓	
Overlay E2									✓

New Service Replacement (SR) Model

- **Max** number of all applications RX, BX, CX, 400 level
- **Save time** when emergency replacement needed
- **Reduce complexity** of carrying/stocking multiple types for service calls
- **Simplify** your enterprise with one controller that does the max of everything

Site Aggregator (SA)

- True System Supervisor. Dedicated processing power and memory for logging and analytics
- Single view of controllers, compatible with E2's and Supervisors
- Overlay Existing E2 network

Supervisory Control Software Differences

Features and Benefits



Connecting to the E3 thru Internal Webpage



All configuration can be accomplished through the E3's Built-in Display, Remote Display or laptop, PC. **No Software Needed**

- IP Address 192.168.1.250 – Port 1
- IP Address 192.168.0.250 – Port 0

New Control Software Features

Software Features

Supervisory Control Software provides the Same Control Function as E2, and includes new:

- Faster Response and Navigation
- Text and Email Alerting
- Prioritized Alarms
- Floor Plan Views
- Aggregate Devices
- Enhanced Upstream Communication Capabilities
- Intuitive Navigation with Graphical Interface
- Increased Security
- Increased Network Functionality
- No Additional Software Needed



Emerson Retail Solutions Apps and Popular Sites



EMERSONTM

Training

<https://emersonbeta.myshopify.com/pages/instructor-led-courses>

Software Updates

<https://climate.emerson.com/en-us/products/controls-monitoring-systems/facility-controls-electronics/facility-and-system-controls/>

Technical Support Material

Using the E2 setpoint conversion tool when retrofitting E2 with supervisory or E3 controllers: Using UltraSite32mm version 5.10 and above

Technical Bulletin

When retrofitting E2 with supervisory controllers, a backup/restore process should be performed on the E2 controller. The supervisory controller will run the same devices and applications as the E2, but instead of manually entering the information, the setpoints and configurations can be automatically converted from the E2 to the supervisory controller using UltraSite.

The conversion tool can be expected to convert 80% or more of your E2 backup file. The conversion process will take between 10 to 20 minutes depending on the complexity of the backup file. You must do a side-by-side comparison of the E2 backup file and the newly converted Supervisor file to verify there are no errors. It will be necessary to review all setpoints and alarms for consistency in addition to the error log report and restore comparison log (see Figure 13) that is generated at the end of the conversion process to ensure your new system will run properly.

Licensed features and 3rd-party integrations will not convert if your new controller does not have the licenses or features installed.

Note that some complex schedules and Flex Combiners may not be converted.

If you feel there is something that should have been converted but did not, or if there is an error that shows a setpoint or parameter did not convert correctly, please contact Emerson Technical Support.

Step 1: Set up Supervisor in UltraSite

1. Log into UltraSite as user/pass.
2. Add Supervisor as a Site (right-click **Directory** and click **Add Site**).

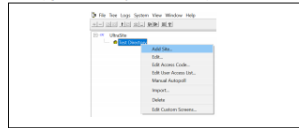

Figure 1 - Click Add Site

Document Part # 026-4050 Rev 1
©2020 Emerson Retail Solutions, Inc. This document may be photocopied for personal use.
Visit our website at <http://www.climate.emerson.com> for the latest technical documentation and updates.

Page 1 of 8



[Conversion Tool](#)

Supervisory Controller Installation and Operation Manual



Site Supervisor Version 2.13
026-1800 Rev 17



[Supervisor Controller Manual](#)

Site Supervisor Controller Quick Setup Guide

The Site Supervisor is a system that combines energy management with the ability to monitor various facility systems and provide alerts when there are issues that need attention. This system provides HVAC control, Refrigeration System Monitoring and Control, as well as Lighting Control. In addition, the Site Supervisor can monitor and report energy consumption and take action to reduce the energy demand during peak periods. This can have a direct impact on utility bills by reducing total energy costs. Site Supervisor ensures that the HVAC and lighting systems are on and off at the appropriate times. This ability to monitor store conditions can potentially minimize energy consumption.

For a copy of the full Site Supervisor Guide (P/N 026-1800), visit the Site Supervisor page on the Emerson website: <http://climate.emerson.com/en-us/products/controls-monitoring-systems/facility-controls-electronics/facility-and-system-control/site-supervisor>. Facility control to download or contact Emerson Electronics and Solutions Customer Service at 770-425-2724.



Figure 1 - Site Supervisor

Ethernet Connection

1. ETH1 is designed to be used for directly connecting to laptop, PC, or optional touchscreen with a CAT5 network cable.
2. The default IP for ETH1 is 192.168.1.250.
3. The optional Site Supervisor Display touchscreen default IP is 192.168.1.200 and will connect automatically to the Site Supervisor when plugged into ETH1. **It is recommended that you do not change these defaults.**

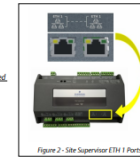

Figure 2 - Site Supervisor ETH1 Ports

4. ETH0 should be reserved for the secure network connections: store or corporate networks. Ask your network administrator for the correct network IP address for ETH0.
5. ETH0 and ETH1 are physically separated for added security. Directly connecting to ETH1 will not access the secure network connection on ETH0.

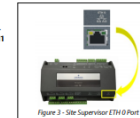

Figure 3 - Site Supervisor ETH0 Port

Document Part # 026-4144 Rev 11
©2020 Emerson Climate Technologies Retail Solutions, Inc. This document may be photocopied for personal use.
Visit our website at <http://www.emerson.com> for the latest technical documentation and updates.

Page 1 of 11



[Supervisor Quick Setup Guide](#)



24/7 Technical Support

Email - coldchain.technicalservices@emerson.com
Phone Number – [833-409-7505 \(opt 2\)](tel:833-409-7505)

[Offline Manager](#) - offlinemanager.emerson.com

Share Your Feedback!



To receive an electronic training certificate:

1. Scan or visit nasrc.org/session-surveys
2. Provide your name and email at the end of the survey

Please Note: You will not receive a certificate unless you share your name on the survey form.

CO2 Climate Study, TCO Study, ESG Goals and Controls Transition Plans for Food Retailers.

Andre.Patenaude@Copeland.com

Mike.Hill@Copeland.com

Copeland



Back Up