

# Natural Refrigerant Training Summit

Building a Sustainable Workforce

---

## Introduction to CAREL CO2 Rack Control

Chris Butler

CAREL



NORTH AMERICAN  
Sustainable  
Refrigeration  
Council

**BETTER** CONTROL  
**BETTER** ENVIRONMENT

**CAREL**

# *Rack Control Training*

*pR300T*

*Chris Butler*  
*Nov. 2023*

# Holup, boss...

## What we are sorta NOT covering...

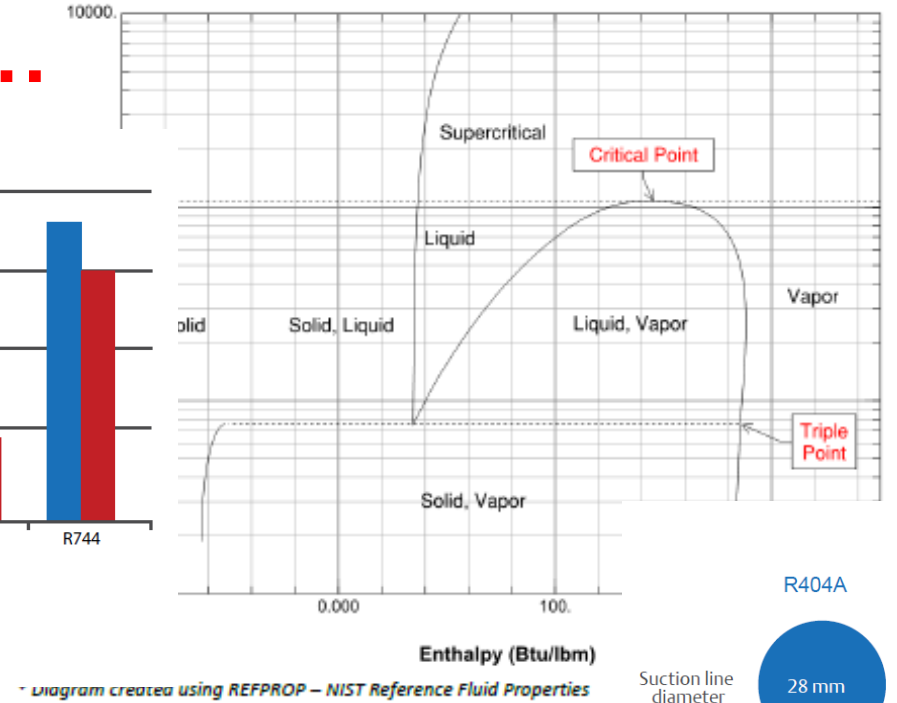
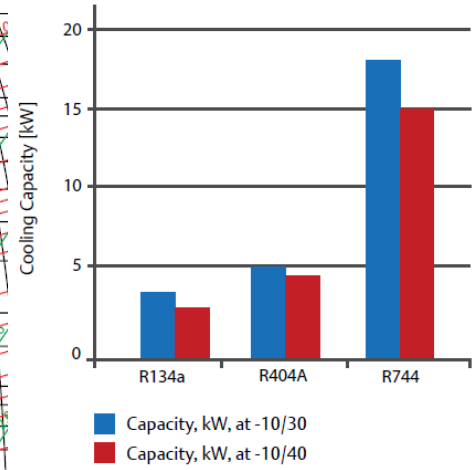
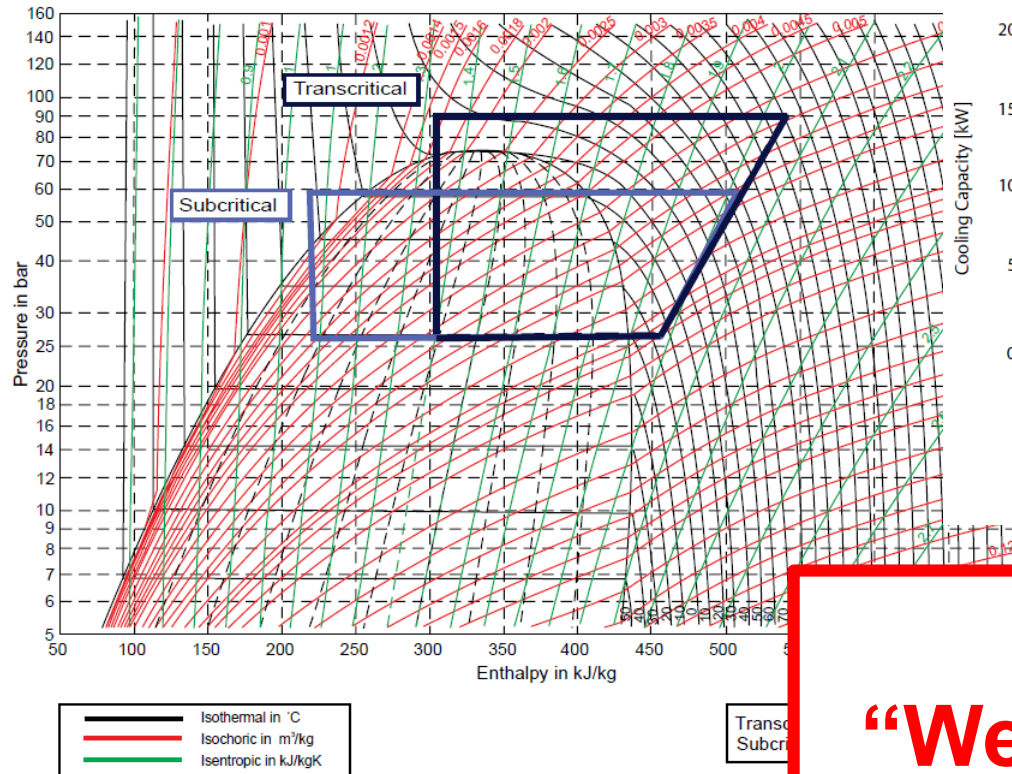

“Well this other controller...”

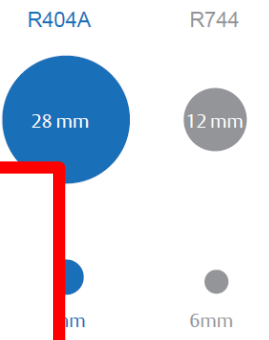

CAREL

SERVICES

# Technical Support

# Online Info

Visit the CAREL website

- <https://www.carelusa.com/>

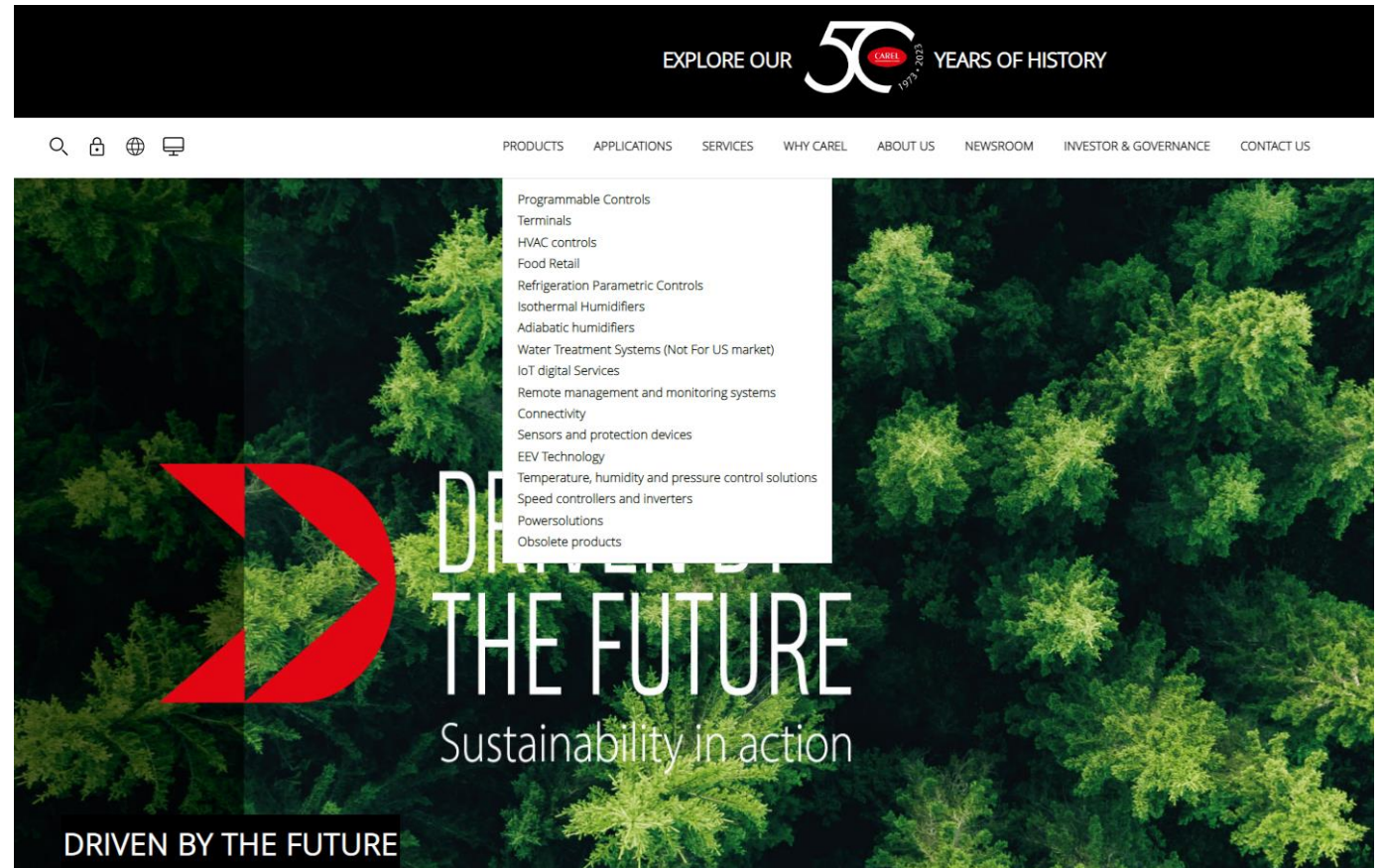

# Online Info

Visit the [CAREL YouTube Channel](#)

The screenshot displays the CAREL YouTube channel page. On the left is the YouTube navigation sidebar with options like Home, Shorts, Subscriptions, Library, History, Watch Later, Liked videos, Subscriptions (Music, Sport, Gaming, Movies & TV), and Explore (Trending, Shopping, Music, Movies & TV, Live, Gaming, News). The main content area features a banner image with icons for snowflake, cloud, heart, flame, and water drop. Below the banner is the channel header with the CAREL logo, name, handle @CARELHQs, and 6.23K subscribers. A 'Subscribe' button is visible. The video player shows a video titled 'Relative humidity and respiratory infections' with 598 views from 6 months ago. The video description discusses the human body's design for relative humidity and lists mechanisms like mucociliary clearance and viral infectivity. Below the video is an 'About CAREL' section with a 'Play all' button and a row of six video thumbnails.



# Online Info

Visit the CAREL Courses website

- <https://learning.carel-deutschland.de/en/courses>

\*\*Be sure to click the  
“SIGN UP” button\*\*

CAREL

SIGN UP

LOGIN

COURSES | watch learn innovate

CATEGORY ▾ LEVEL ▾ GENRE ▾

↓ SORT BY 🔍

FREE

CAREL *iJW:*  
the Refrigeration Controller  
for Smarter Field  
Commissioning  
Stefano Soggia  
Piero Zanchetta  
12/2022

IJ-W | Launch Event  
Various Artists

FREE

IJ-W  
Piero Zanchetta

FREE

µRack  
Federico Ferrari

FREE

CMALDSE002 - Panel for cabinets  
with MPXpro  
Timo Kaufhold

FREE

E3V-B

FREE

E2V-H

FREE

E2V-C

FREE

pGD



# Technical Services Phone & Email Support

CAREL

- **US Based Customers:**  
**1-833-809-7267**

- **By Email:**  
**[SERVICES.USA@CAREL.COM](mailto:SERVICES.USA@CAREL.COM)**

- **Canadian Based Customers:**  
**1-412-446-3646**

- **For Field Visit Request:**  
**[FIELD.SERVICES@CAREL.COM](mailto:FIELD.SERVICES@CAREL.COM)**

REPAIRS



TECHNICAL SUPPORT



SPARE PARTS

CAREL



Where are we and what  
are we controlling?

Rack control!

# CO2, Parallel compression, Loop Piping

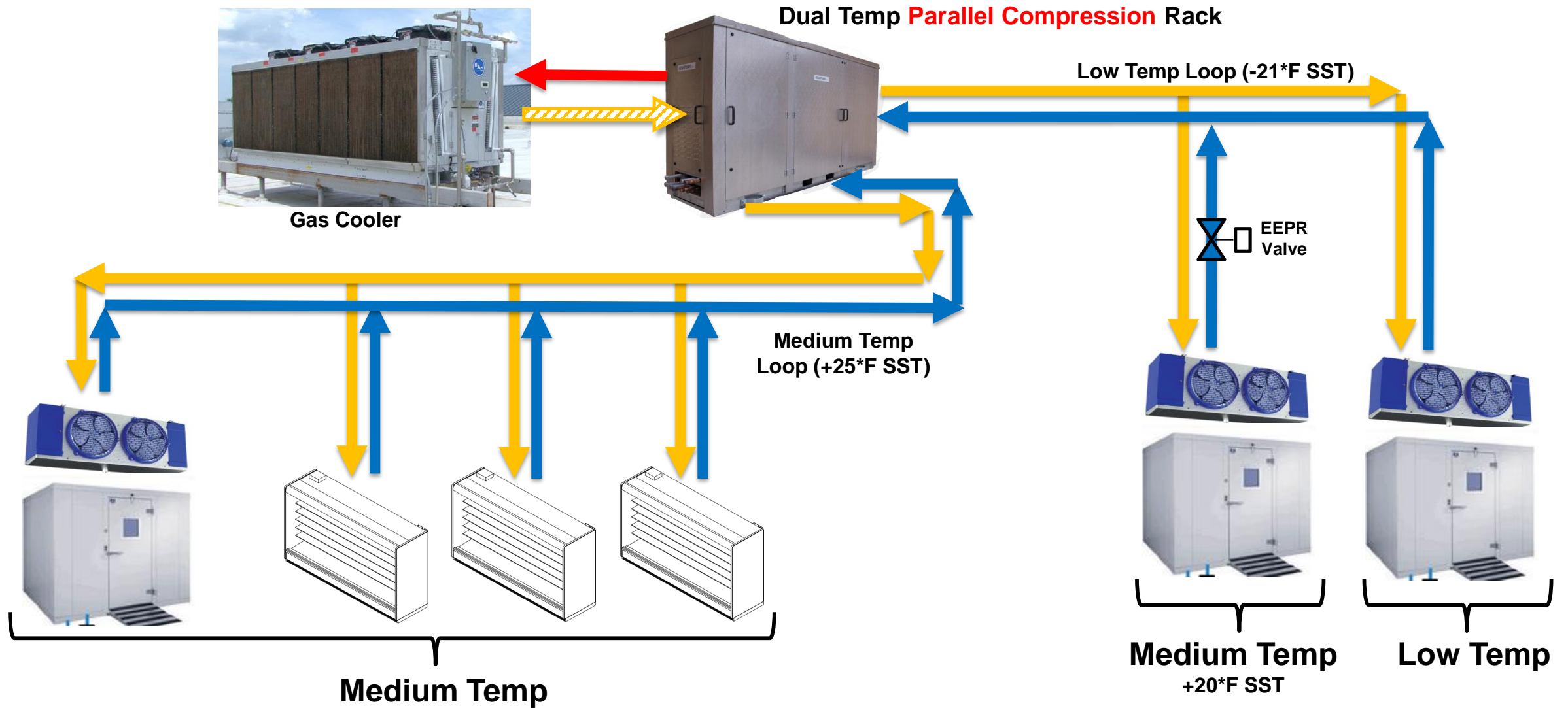

# Distributed Control

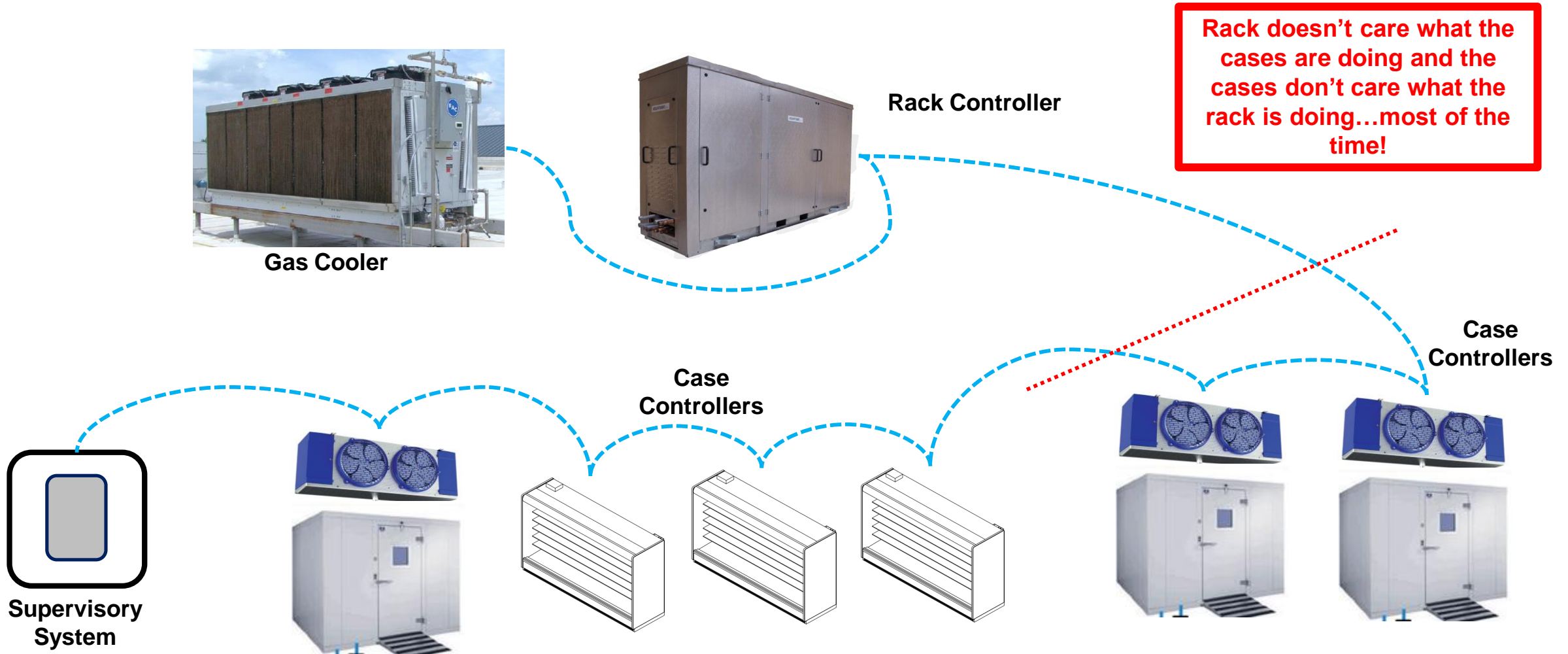

# Decentralized Control System

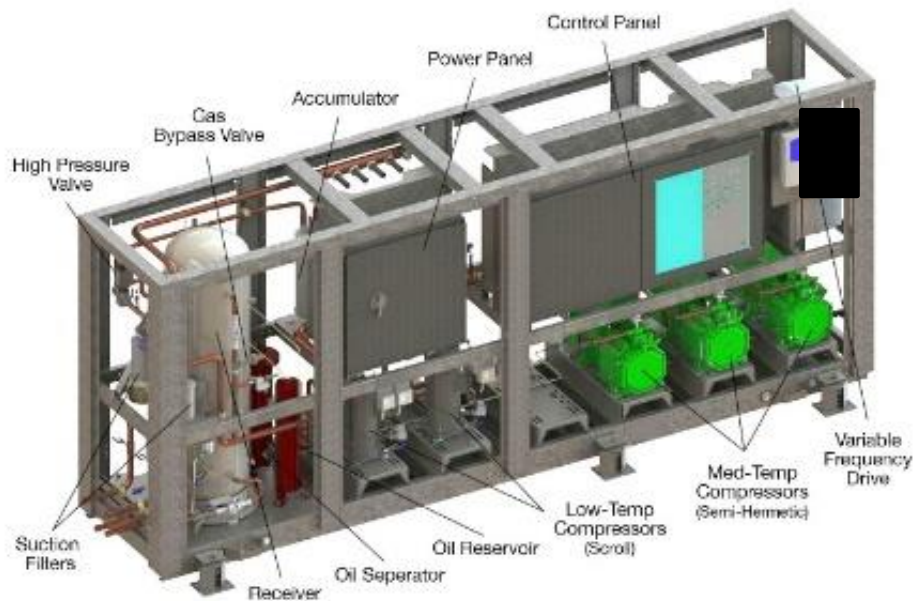

**The job of the rack controller is to:**

- Provide quality liquid
- Provide quality suction

**A break in comms? So what! Things should keep running!**

**The job of the case controller is to:**

- Cool or not. Can regulate temperature

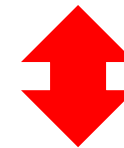
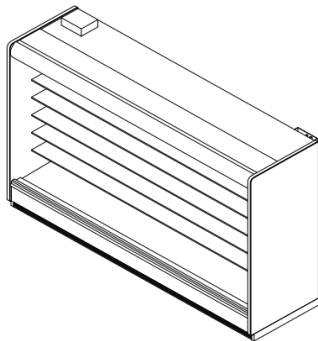

**We work together!**

**The job of the superheat controller is to:**

- Regulate superheat
- Smooth Lines! No on/off control. “Floating” superheat.

What are we using for rack control?

pR300T!

# pR300T Hardware



# pR300T Quick Summary

- **Transcritical/Subcritical CO2**
- **Booster system**
- **Built in display and/or a handheld display**
- **Optional on board valve control**
- **Multiple boards can be connected together**
- **Wizard for initial programming/parameter setting**
- **Backup to controller, laptop, or USB drive**
- **Configurable I/O**
- **What you don't use you can't see**
- **Configurable to your application: Dual Temp (CO2 Booster) Medium Temp, Low Temp, Condenser Control**
- **\*\*\*Can be used as standalone HPV/Flash Gas valve controller\*\*\***

**WATCH OUT!!**  
L1 = Medium Temp  
L2 = Low Temp  
...always!

# pR300T



**pR300T**

**pR300T w/  
Driver and  
Ultracap**





# Watch Out!

Upper retaining tabs are fixed!

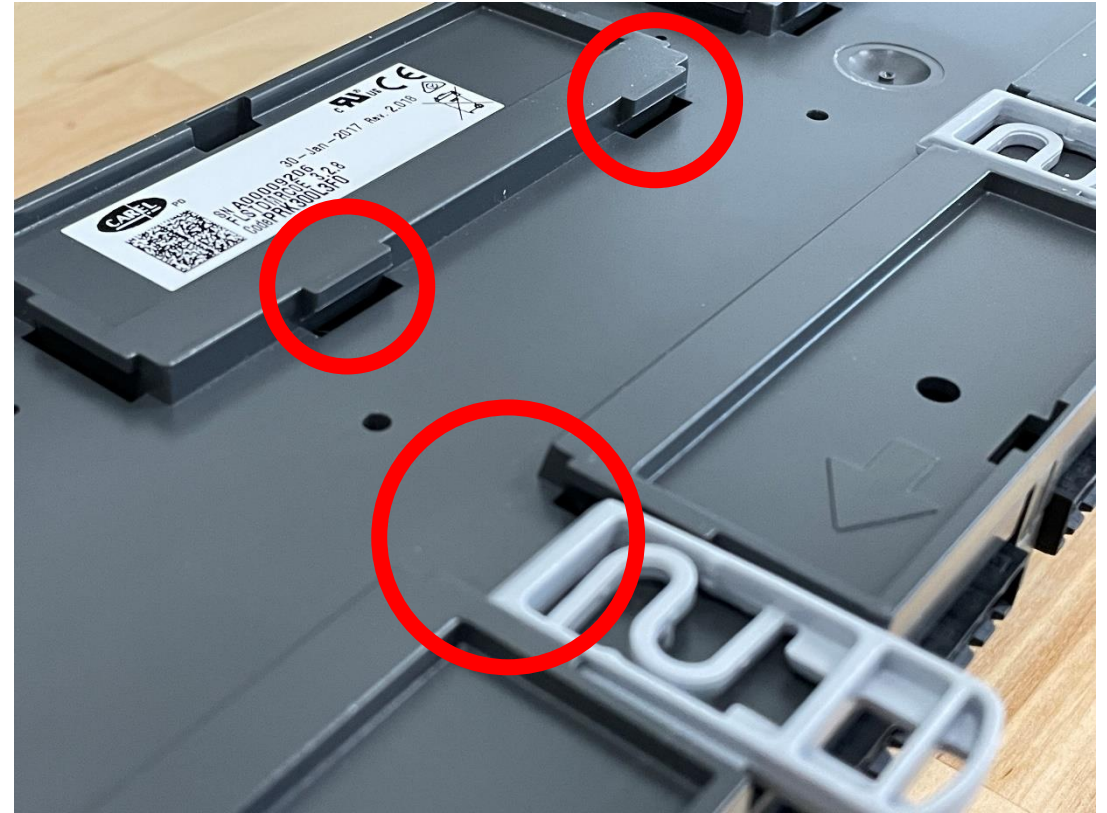

A few examples...

# pR300T

Hmmmm....



# What's in the panel?

**EVDevo**

**pR300T PR1  
L1 Medium  
Temp and  
Gas Cooler**

**pR300T PR2  
L2 Low  
Temp**

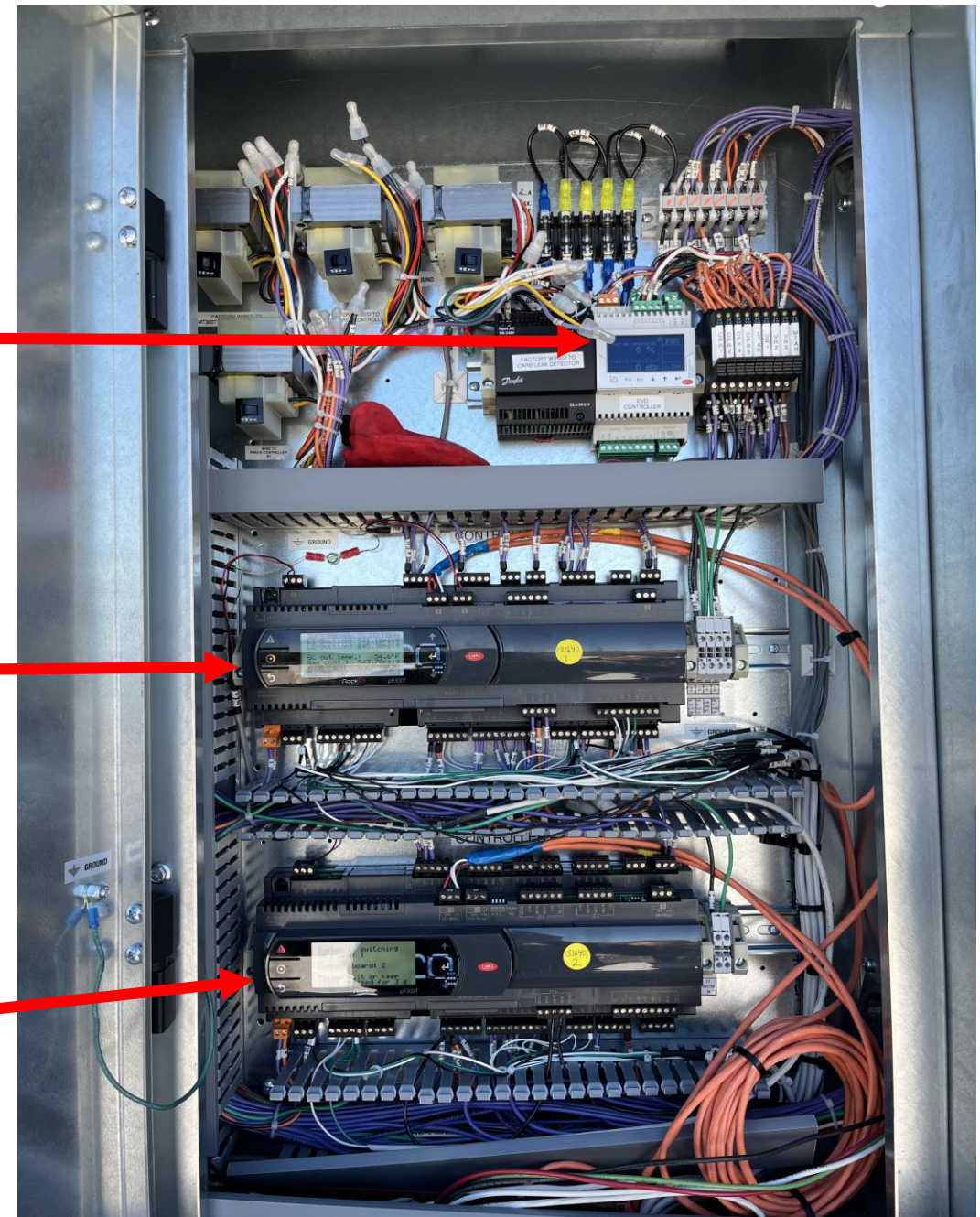

Networking

# Distributed Control



Gas Cooler

0 – 10V Signal



- Each pRR300T has it's own Modbus address
- Belden 8761, 8762; 22, 20 AWG 1 single pair 2 insulated wires + 1 uninsulated wire
- Belden 9841; 24 AWG 1 single pair 2 insulated wires + 1 uninsulated wire
- Belden 3106A; 22 AWG 1.5 single pair 3 insulated wires + 1 uninsulated wire

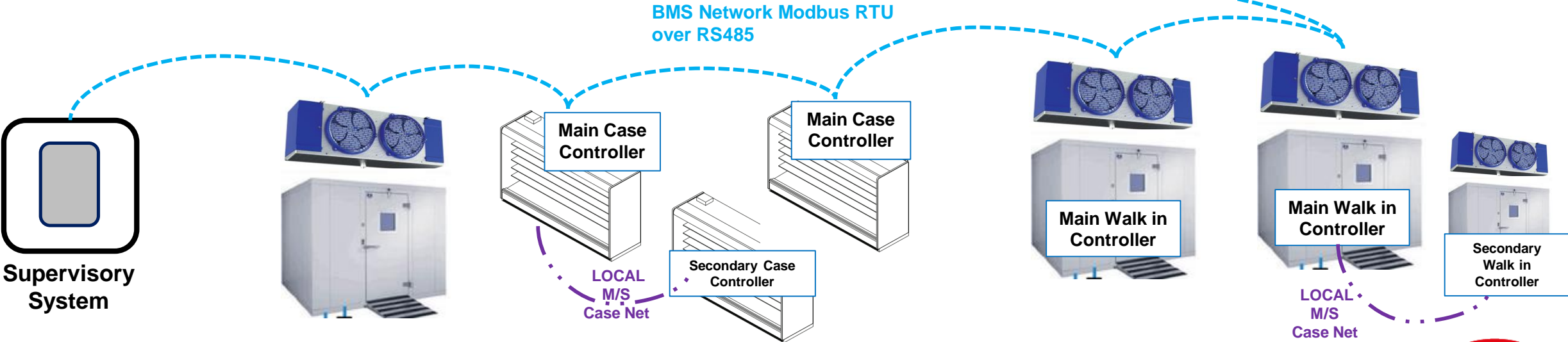

# Network Example: pR300T Multi Board

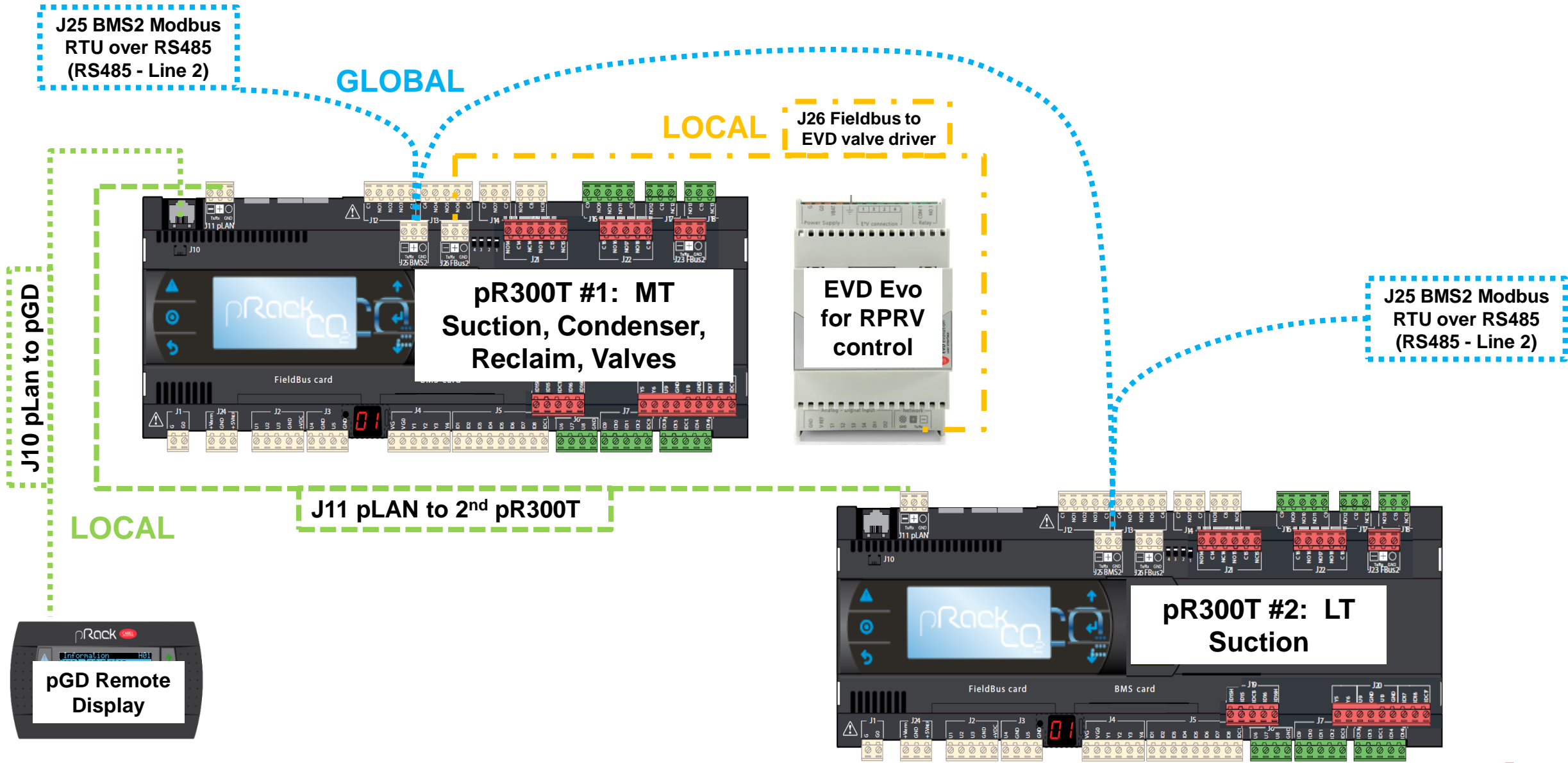

# Network Example: pR300T w/ Driver & Exp. Board

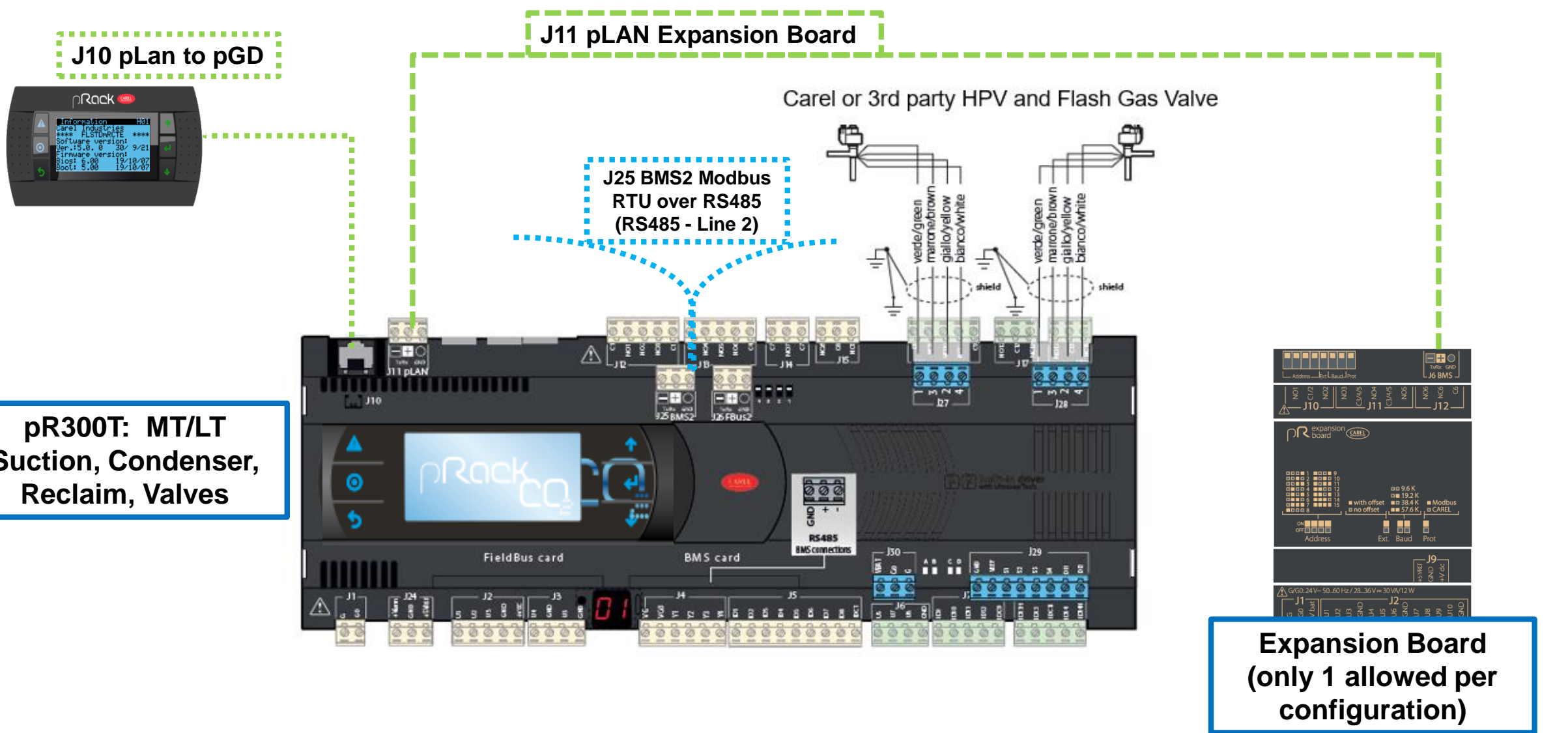

**pR300T: MT/LT Suction, Condenser, Reclaim, Valves**

**Expansion Board (only 1 allowed per configuration)**





Wiring: I/O

# pRack – I/O Overview

- Universal I/O can be configured for different uses:
  - Temperature probes: NTC, PTC, PT1000
  - Active pressure/temperature/humidity probes
  - Ratiometric pressure probes 0 – 5 V
  - Current inputs, 0 to 20 mA or 4 to 20 mA
  - Voltage inputs, 0 to 1 Vdc or 0 to 10 Vdc
  - “Wet” and “dry” digital inputs
  - Analogue outputs, 0 to 10 Vdc, 10 Vdc to 0 or PWM
- Digital Outputs:
  - most, but not all, are Form A (normally open)
  - Optional SSR’s
- **Each connector is grouped by J##**
- **J## and individual pins are identified by silk screen on controller**
- **Where a wire lands is up to the programming and can be moved in most cases**
- **Yes, the gold silkscreen is hard to read**

# pR300T: Layout

## pGD Remote Display

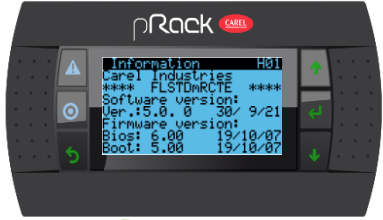

pLAN to pGD

## Temperature probes

- NTC
- NTC HT



## Pressure probes

- 4-20 mA
- 0-5 Vdc

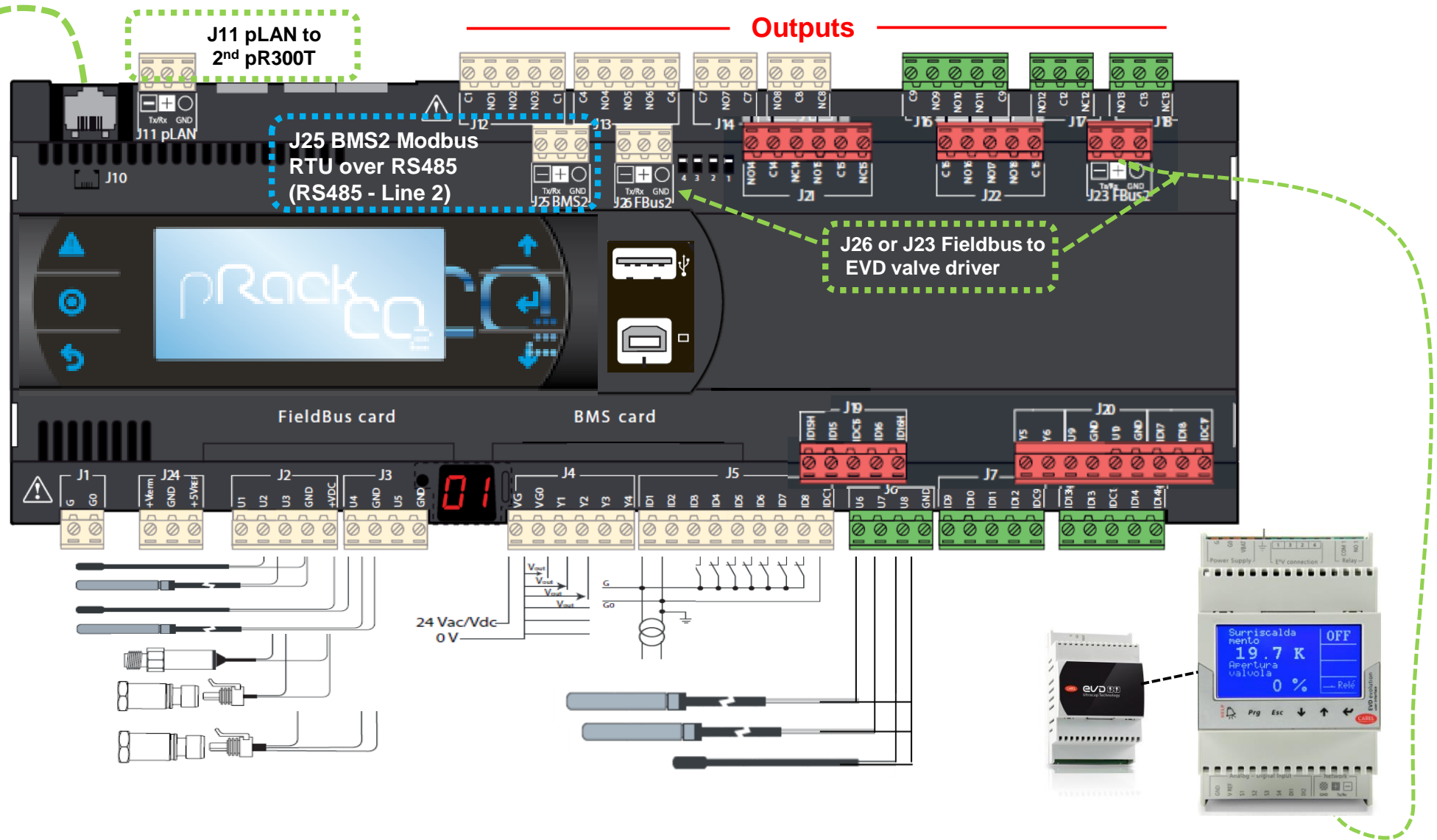

# Analog Inputs



- “U” means “Universal”
- U1
- U2
- And so on...

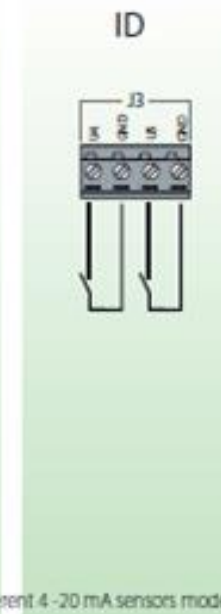
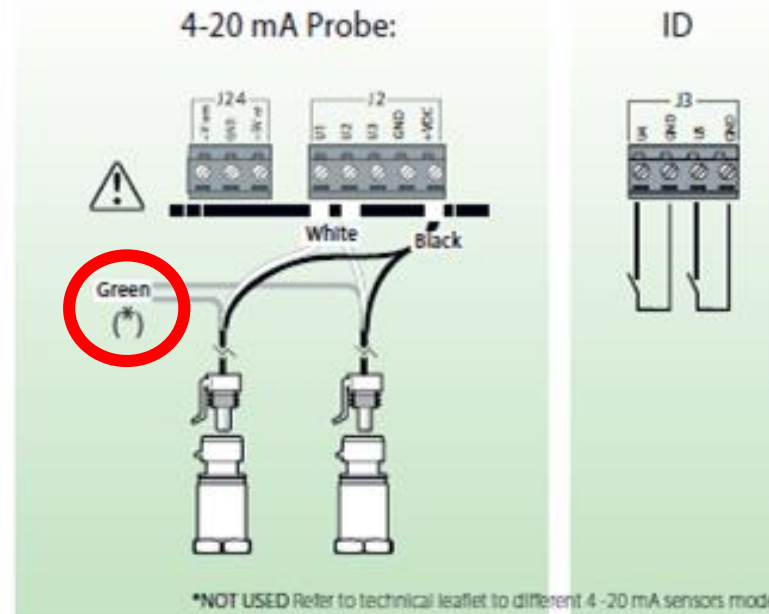
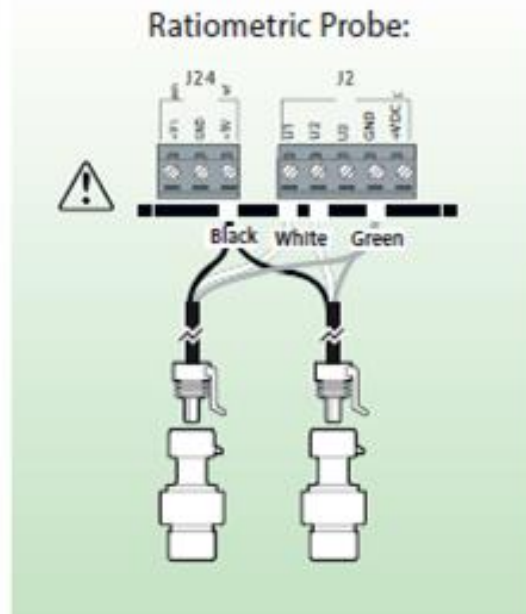
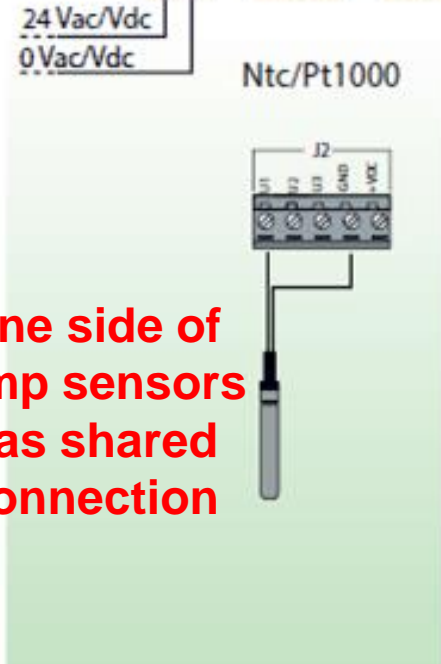

- +VDC = ~24Vdc (4-20 mA)
- +5V = 5Vdc
- Vterm = ~21Vdc (terminal)

One side of temp sensors has shared connection

# Digital Inputs

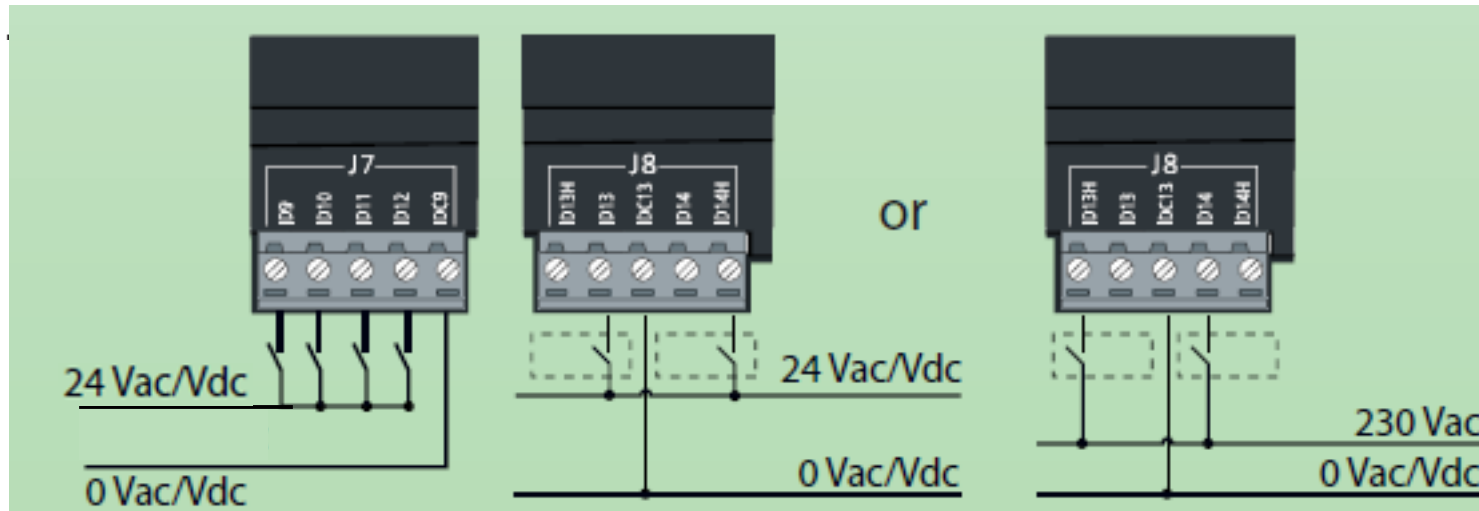

- Most of the Digital Inputs are “wet”, however, J3 and J20...

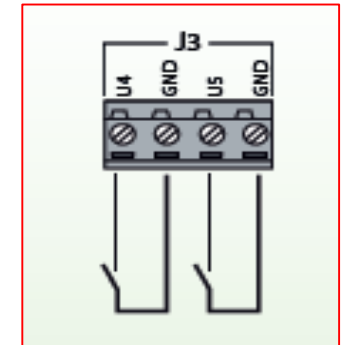

- Silk screened and identified in manual as “ID”

# Analog Outputs

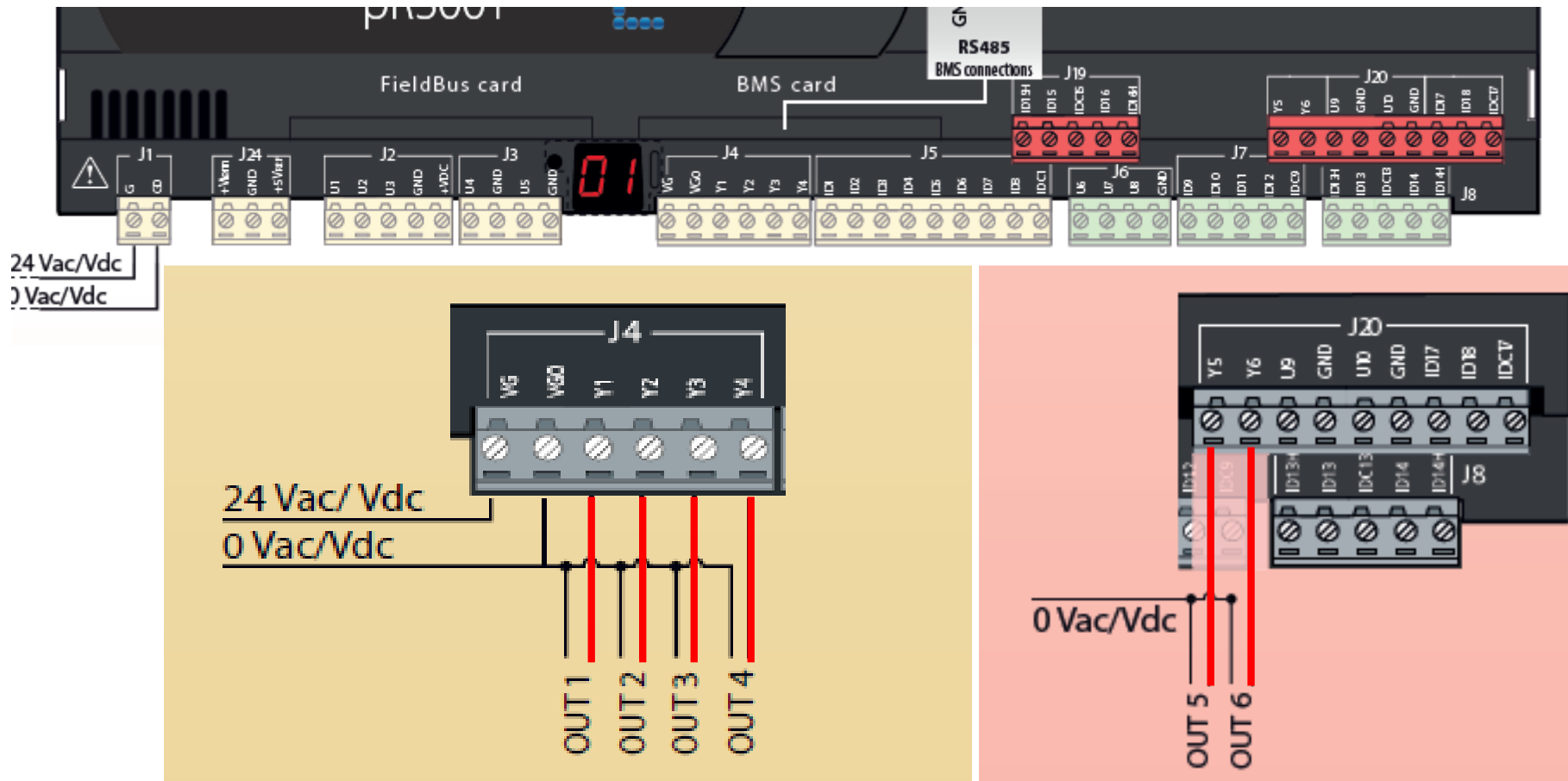

Identified as “Y#”  
on controller

“VG” is the voltage  
source for all  
Analog Outputs.  
Voltage at VG is  
regulated and  
output from each Y#

Use your meter to  
measure between  
VG0 and Y# to read  
the DC output

# Relays

## ■ Medium

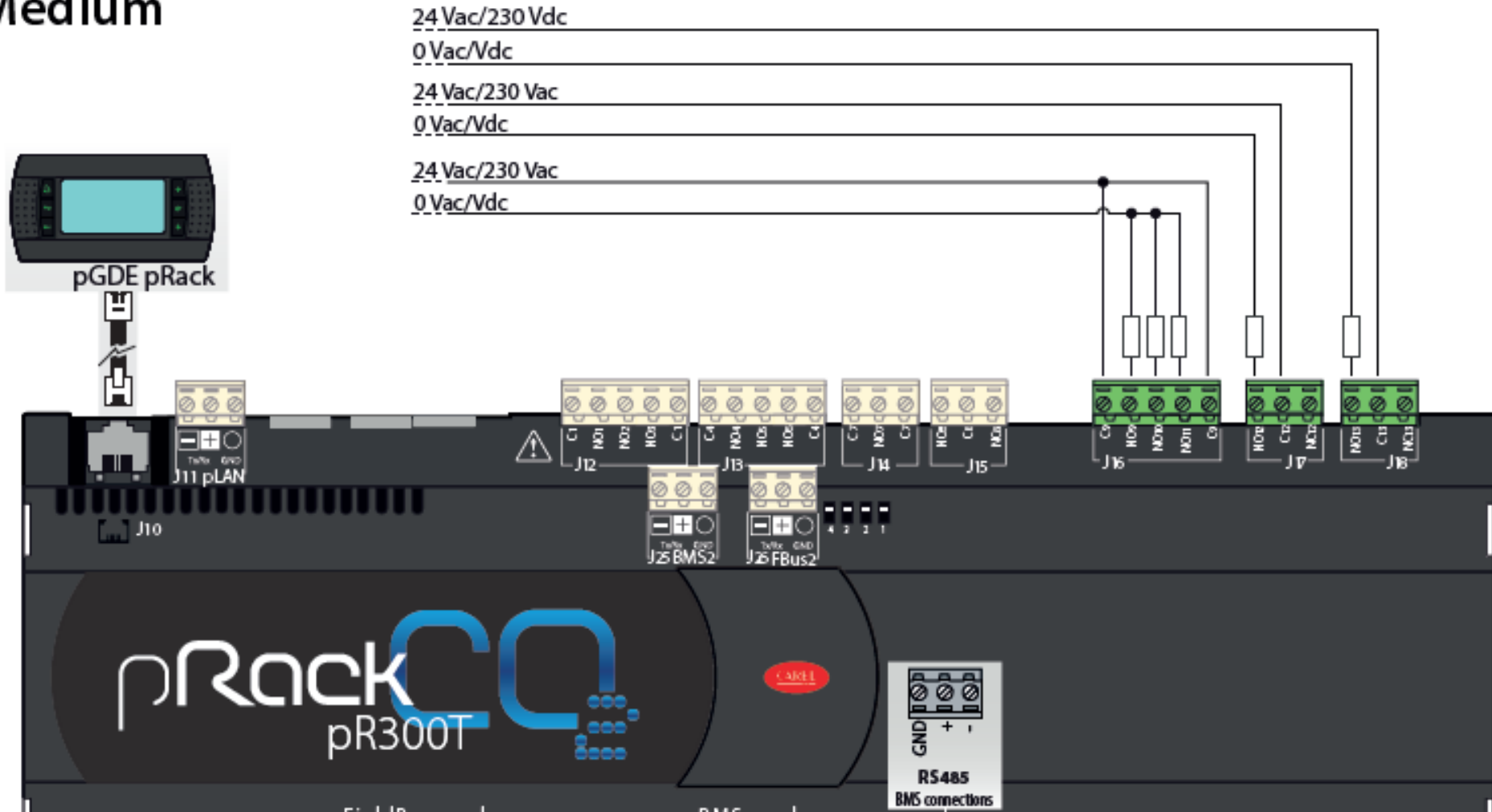

# Sensor Connections

4 – 20 mA Pressure Sensors

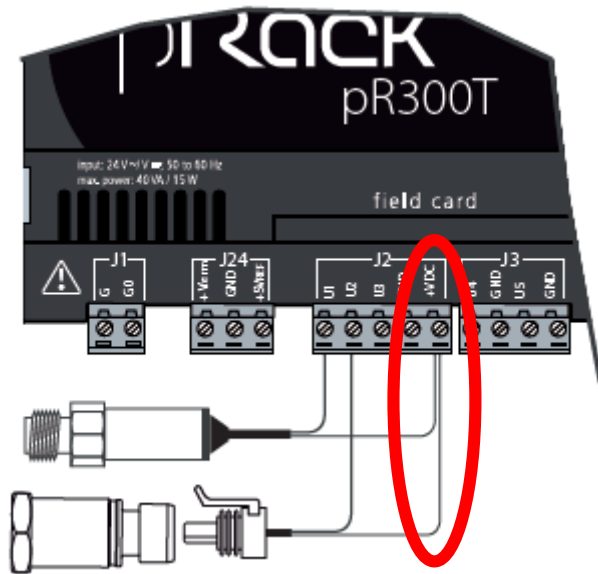

DO NOT CONNECT GREEN WIRE; CAP OFF. **Power from +VDC terminal**

0 – 5 V Pressure Sensors

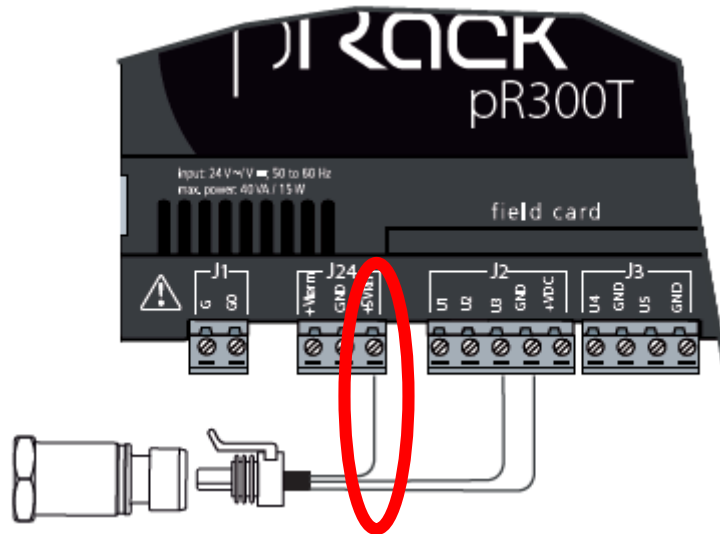

REMEMBER TO MATCH UPPER AND LOWER LIMITS IN CONTROLLER.  
**Power from +5VRef**

NTC Temperature Sensors

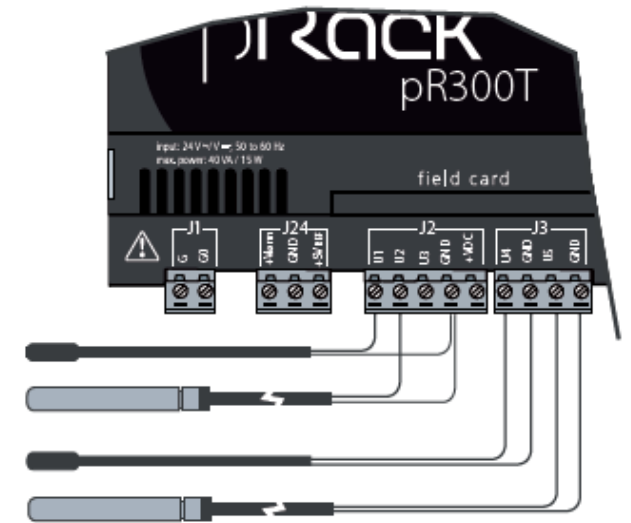

NOTE GND CONNECTIONS



# Pressure Sensors

To protect the sensor against damage from inducted overvoltage and incorrect use, the following measures are recommended:

Pressure transducers require removal **prior to vacuum test and cannot be exposed to a deep vacuum**

Avoid winding the cable in spirals, and adequately separate the cable from the power cable.

Receiver pressure: (SPKT00G1S0) 0–60 bar, 0–870 psig, **0-5V**



MT Suction pressure: (SPKT00B6P0) 0-45 BARG, 0-650 PSIG, **0-5V**



MT Discharge pressure: (SPKT00D8C0), 0-150 bar, 0-2175 psig, **4 – 20ma**, Gas 1/4 MPT (straight thread, o-ring included)



# Temperature Sensors

NTC\*\*WF\*\* -- Standard Temp

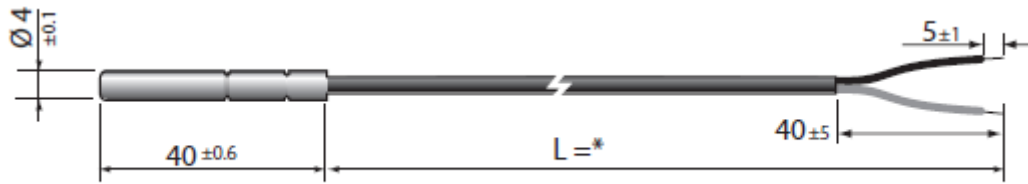

Fig. 2.c

**STANDARD TEMP. RESISTANCE READINGS ARE DIFFERENT THAN THE NTC\*\*HT\*\* SENSOR. NTC 10K, BETA 3435**

5.1 Table of temperature-resistance values for NTC sensor 10K@25°C B 3435

Temp. °C	Resistance value		
	Max. KΩ	Typical KΩ	Min. KΩ
-50	344,60	329,50	314,90
-49	325,00	310,90	297,30
-48	306,60	293,50	280,90
-47	289,40	277,20	265,40
-46	273,40	262,00	251,00
-45	258,30	247,70	237,40
-44	244,20	234,30	224,70
-43	231,00	221,70	212,80
-42	218,60	209,90	201,60
-41	207,00	198,90	191,00
-40	196,00	188,50	181,10
-39	185,50	178,50	171,60
-38	175,60	169,00	162,60
-37	166,30	160,20	154,20
-36	157,60	151,90	146,30
-35	149,40	144,10	138,80
-34	141,70	136,70	131,80
-33	134,50	129,80	125,20
-32	127,70	123,30	119,00
-31	121,20	117,10	113,10
-30	115,20	111,30	107,50
-29	109,40	105,70	102,20
-28	103,90	100,50	97,20
-27	98,68	95,52	92,45
-26	93,80	90,84	87,97
-25	89,20	86,43	83,73
-24	84,85	82,26	79,74
-23	80,76	78,33	75,96
-22	76,89	74,61	72,39
-21	73,23	71,10	69,01
-20	69,77	67,77	65,82
-19	66,44	64,57	62,74
-18	63,30	61,54	59,83
-17	60,32	58,68	57,07
-16	57,51	55,97	54,46
-15	54,85	53,41	51,99
-14	52,33	50,98	49,65
-13	49,95	48,68	47,43
-12	47,69	46,50	45,32
-11	45,55	44,43	43,33
-10	43,52	42,47	41,43
-9	41,55	40,57	39,60
-8	39,69	38,77	37,86
-7	37,92	37,06	36,21
-6	36,25	35,44	34,64
-5	34,66	33,90	33,15
-4	33,15	32,44	31,73
-3	31,72	31,05	30,39
-2	30,36	29,73	29,11
-1	29,06	28,48	27,89
0	27,83	27,28	26,74

Temp. °C	Resistance value		
	Max. KΩ	Typical KΩ	Min. KΩ
1	26,65	26,13	25,62
2	25,52	25,03	24,55
3	24,44	23,99	23,54
4	23,42	23,00	22,57
5	22,45	22,05	21,66
6	21,53	21,15	20,78
7	20,64	20,30	19,95
8	19,81	19,48	19,15
9	19,01	18,70	18,39
10	18,25	17,96	17,67
11	17,51	17,24	16,97
12	16,81	16,56	16,30
13	16,14	15,90	15,67
14	15,50	15,28	15,06
15	14,89	14,69	14,48
16	14,31	14,12	13,92
17	13,75	13,58	13,39
18	13,22	13,06	12,89
19	12,72	12,56	12,40
20	12,24	12,09	11,94
21	11,77	11,63	11,50
22	11,32	11,20	11,07
23	10,90	10,78	10,66
24	10,49	10,38	10,27
25	10,10	10,00	9,90
26	9,73	9,63	9,53
27	9,38	9,28	9,18
28	9,04	8,94	8,84
29	8,72	8,62	8,52
30	8,41	8,31	8,21
31	8,11	8,01	7,92
32	7,83	7,73	7,63
33	7,55	7,45	7,36
34	7,29	7,19	7,10
35	7,04	6,94	6,85
36	6,79	6,70	6,61
37	6,56	6,47	6,37
38	6,34	6,25	6,15
39	6,12	6,03	5,94
40	5,92	5,83	5,74
41	5,72	5,63	5,54
42	5,53	5,44	5,35
43	5,34	5,26	5,17
44	5,17	5,08	4,99
45	5,00	4,91	4,83
46	4,83	4,75	4,67
47	4,68	4,59	4,51
48	4,52	4,44	4,36
49	4,38	4,30	4,22
50	4,24	4,16	4,08
51	4,10	4,03	3,95
52	3,97	3,90	3,82
53	3,85	3,77	3,70
54	3,73	3,65	3,58
55	3,61	3,54	3,46

Temp. °C	Resistance value		
	Max. KΩ	Typical KΩ	Min. KΩ
56	3,50	3,43	3,35
57	3,39	3,32	3,25
58	3,28	3,22	3,15
59	3,18	3,12	3,05
60	3,09	3,02	2,95
61	2,99	2,93	2,86
62	2,90	2,84	2,77
63	2,82	2,75	2,69
64	2,73	2,67	2,61
65	2,65	2,59	2,53
66	2,57	2,51	2,45
67	2,50	2,44	2,38
68	2,42	2,36	2,31
69	2,35	2,30	2,24
70	2,28	2,23	2,17
71	2,22	2,16	2,11
72	2,15	2,10	2,05
73	2,09	2,04	1,99
74	2,03	1,98	1,93
75	1,98	1,92	1,87
76	1,92	1,87	1,82
77	1,87	1,82	1,77
78	1,81	1,77	1,72
79	1,76	1,72	1,67
80	1,72	1,67	1,62
81	1,67	1,62	1,58
82	1,62	1,58	1,53
83	1,58	1,53	1,49
84	1,54	1,49	1,45
85	1,49	1,45	1,41
86	1,45	1,41	1,37
87	1,42	1,37	1,33
88	1,38	1,34	1,30
89	1,34	1,30	1,26
90	1,31	1,27	1,23
91	1,27	1,23	1,19
92	1,24	1,20	1,16
93	1,21	1,17	1,13
94	1,17	1,14	1,10
95	1,14	1,11	1,07
96	1,12	1,08	1,04
97	1,09	1,05	1,02
98	1,06	1,02	0,99
99	1,03	1,00	0,97
100	1,01	0,97	0,94
101	0,98	0,95	0,92
102	0,96	0,92	0,89
103	0,93	0,90	0,87
104	0,91	0,88	0,85
105	0,89	0,86	0,83
106	0,87	0,84	0,81
107	0,84	0,82	0,79
108	0,82	0,80	0,77
109	0,80	0,78	0,75
110	0,79	0,76	0,73

Tab. 5.a



# User Interface

# Display: Buttons and Terminology

**View alarms:** press the alarm button once and use the scroll up or down button if multiple alarms are present.

**Reset alarms:** press the alarm button again for 3 seconds

Pressing the menu button and entering the user password will allow you to access the IO list and functions. The default OEM password is 1234.

Pressing the enter button after the parameters are selected will allow you to make changes to the values.

## Terminology:

- **Mask:** Display screen
- **Line:** Group
- **L1:** Line 1, or Group 1

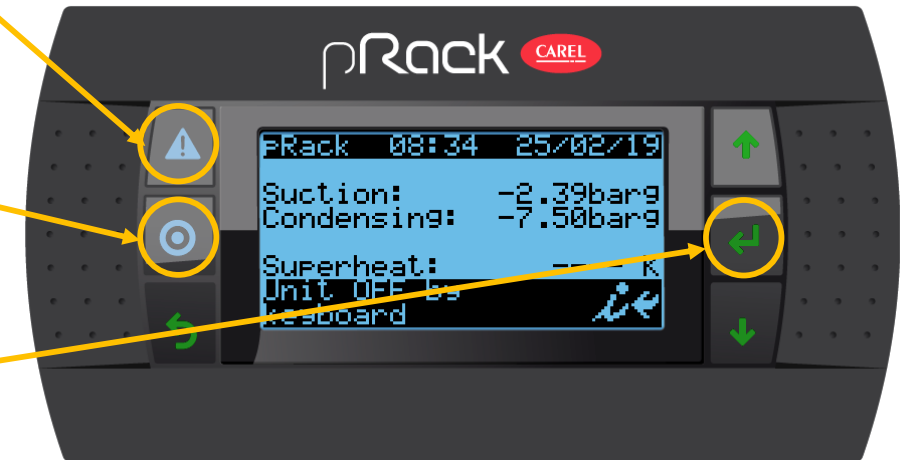

# Display: Rack Operation Overview Screens

**Unit Overview Screens:** Press enter then use the up or down arrows to view pressures, temperatures, and other operating values without logging in. Super helpful!



# LOOK OUT!!!

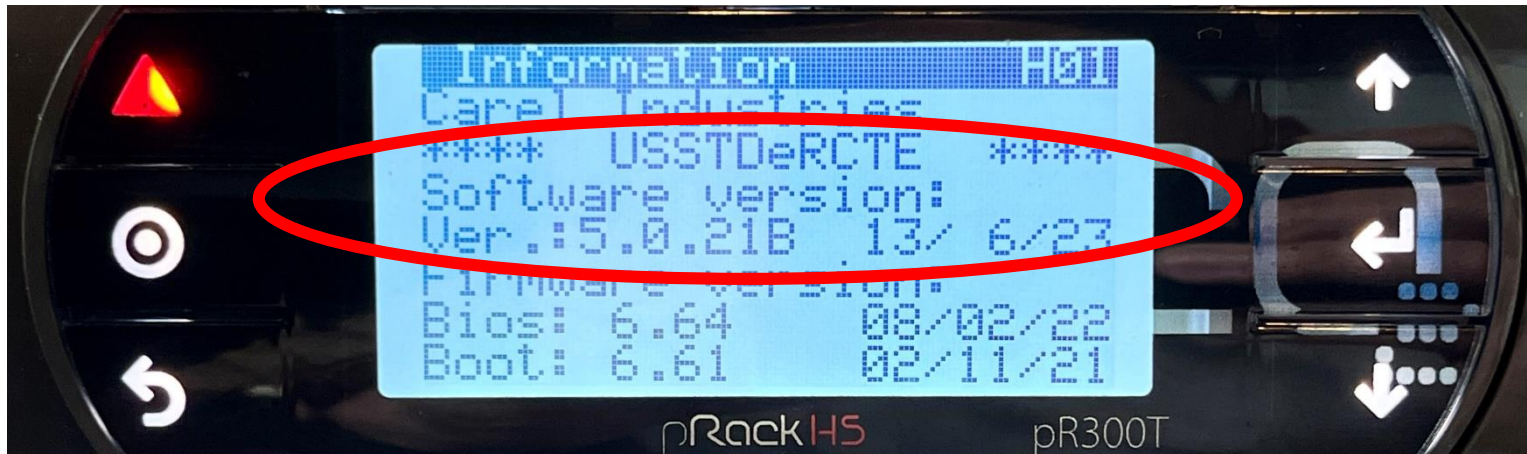

**Software  
Versions!**

# Password and Menus

## pR300T manages three levels of passwords:

- 1. User
- 2. Maintenance
- 3. Manufacturer
- Each level includes the same rights as the lower levels
- Configurable
- **Mess up? You can log in/out via F. Settings**
- **No.**

User	User password	0000
Service	Service password	1234
Manufacturer	Manufacturer password	1234

## Menus:

Branches of menu divided per functions: inside every branch there are parameters and variables relative to the specific function.

Y'all remember (Day Date x 4) + 12?

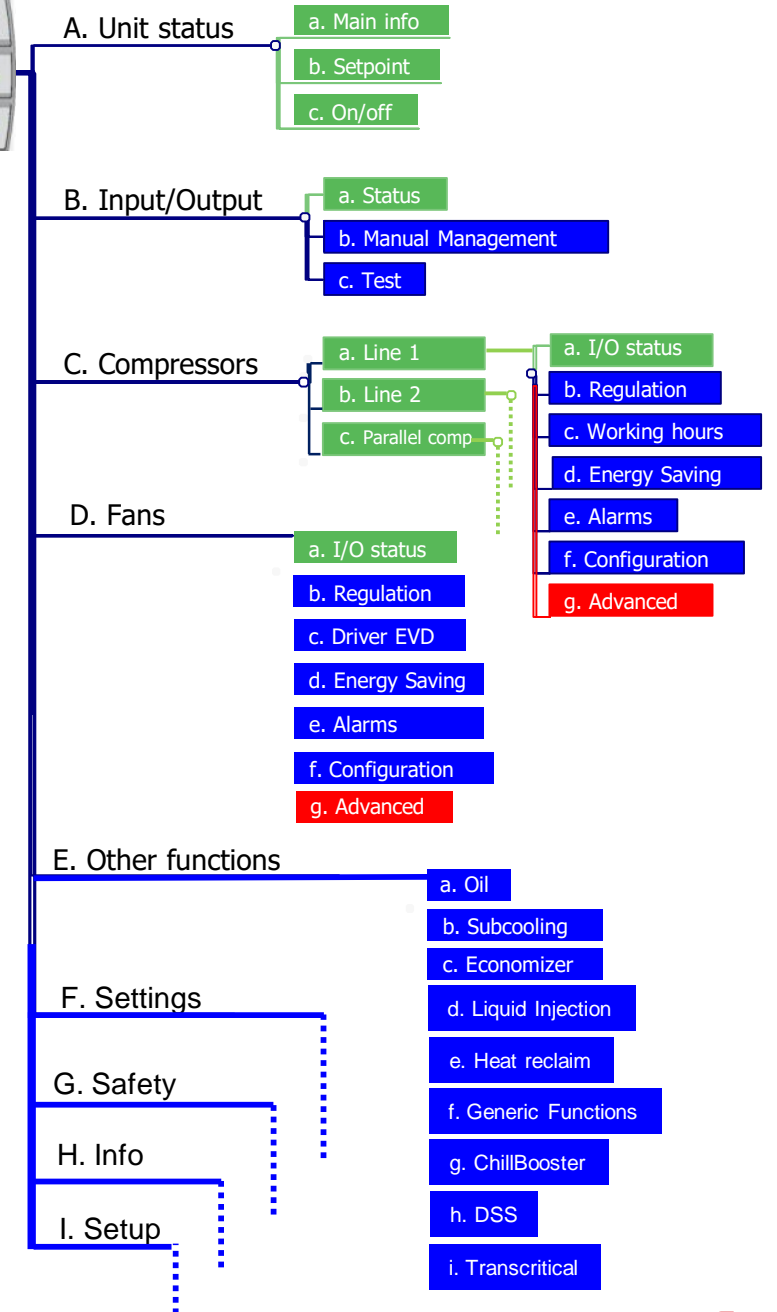
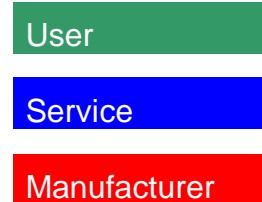
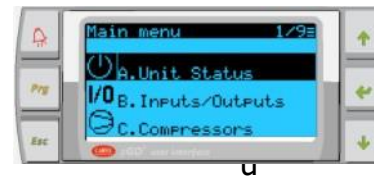

# Main Menu – A. Unit Status

- Main Info
- Setpoint
- On/Off

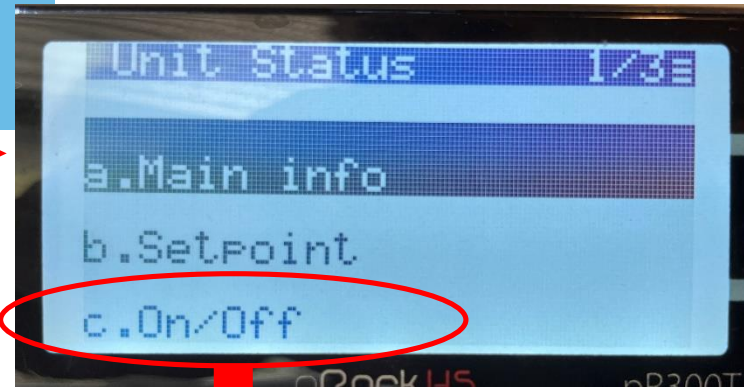
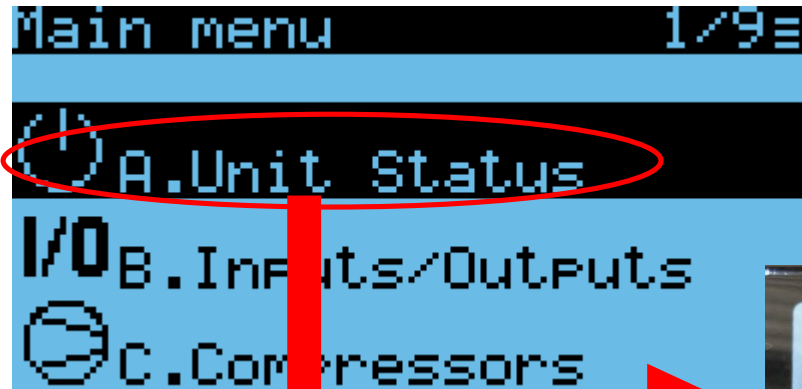



# Main Menu – B. Inputs/Outputs

- **Status:** to see status and change configuration of all enabled inputs and outputs. **The logic (NO/NC) can be changed. You'll see the status (what the controller is seeing at the input) change AND you can see if the function is Active or Not Active.**

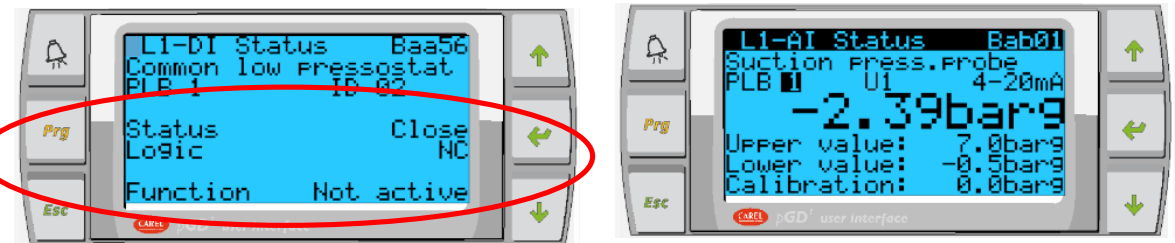

- **Manual management:** bypass *enabled* outputs, respecting alarms, safety times, and start procedures. **\*\*\*Only allowed if the controller is in the OFF mode.\*\*\* Includes vacuum function. Allows you to manually open HPV and Flash Gas Valve. Also helpful to verify wiring.**

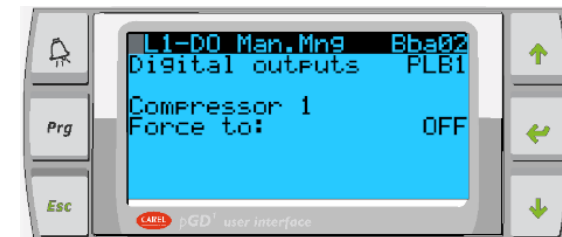

- **Test:** to bypass *any* output **without** timing, protection or safety function. **\*\*\*Only allowed if the controller is in the OFF mode. Mode has adjustable timeout.\*\*\***

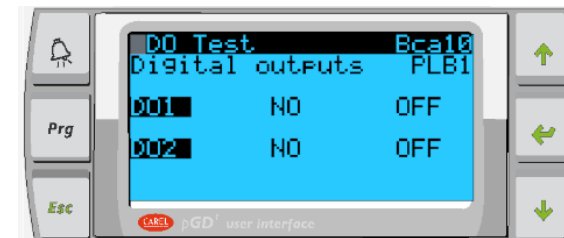

# Main Menu – C. Compressors

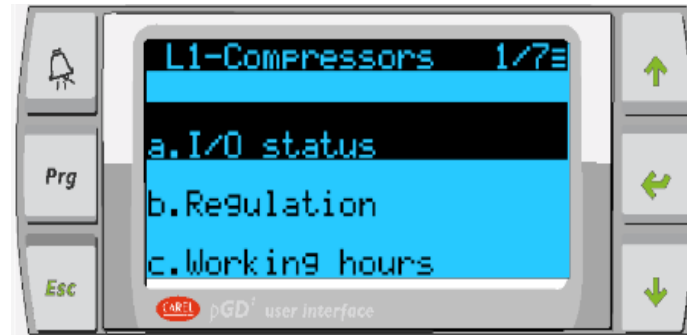

- **I/O status:** all I/O related to the compressors, check status and change settings.
- **Regulation:** regulation settings such as setpoint, differential, type of regulation, timings, etc.
- **Working hours:** to see number of hours the compressors are working or reset the counters.
- **Energy Saving:** Energy Saving Suite. All settings related to compressors energy saving functions.
- **Alarms:** all settings related to compressor alarms, both digital input and probes
- **Configuration:** all standard configuration parameters, timings, etc.
- **Advanced:** contain advanced parameters. Frequencies, non standard configuration, etc.

# Main Menu – D. Fans, E. Other Functions

## D. Fans:

- **I/O status:** all I/O related to the fans, check status, and change settings.
- **Regulation:** regulation settings such as setpoint, differential, type of regulation, timings, etc.
- **Driver EVD:** Not used.
- **Energy Saving:** All settings related to compressors energy saving functions.
- **Alarms:** all setting related to condenser alarms, both digital input and probes.
- **Configuration:** all standard configuration parameters, timings, etc.
- **Advanced:** contain all advanced parameters. Frequencies, non standard configuration, etc.



## E. Other Functions

- Oil
- Subcooling
- Economizer
- Liquid Injection
- Heat Reclaim
- Generic Functions
- ChillBooster
- **DSS**
- **Transcritical Settings**

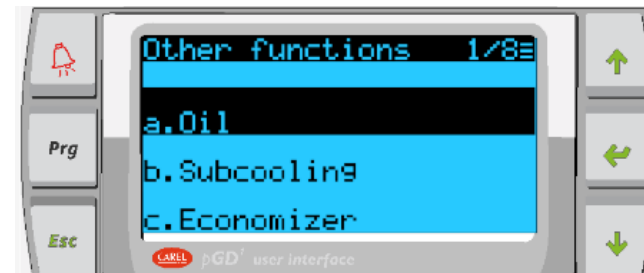

# pR300T More Menus

## **F. Settings**

Contains all the parameters for the main settings of the controller: passwords, language, supervisor parameters, etc.

## **G. Safety**

All settings for common alarms, prevent, etc.

## **H. Info**

Contains information about software version, firmware, BIOS and BOOT.

## **I. Setup**

Contains all the parameters to reset the default configuration or re-start from the start up. **\*\*\*Most of this section requires the unit to be switched OFF via the software switches, Mask Ac02**

First Power Up

# Wizard

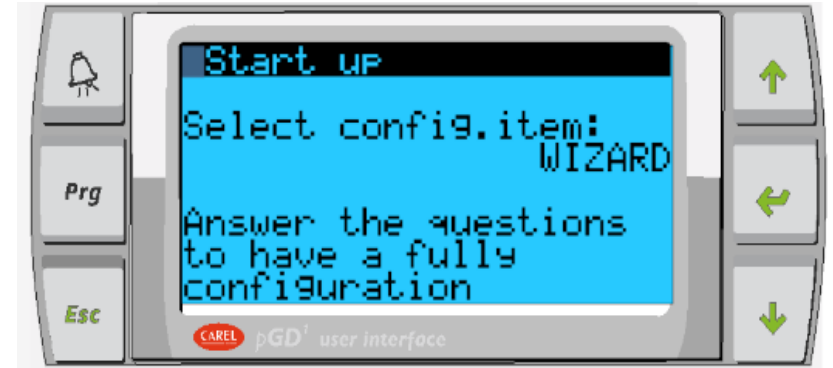
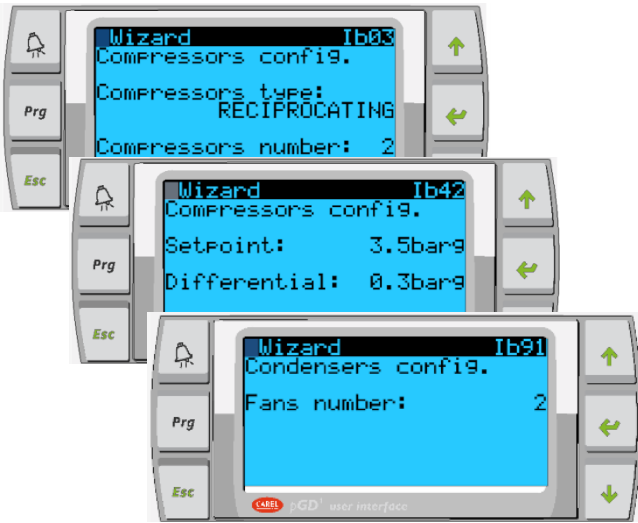

- Step-by-step guided procedure
- **After the Wizard is complete, the controller is ready for work!**

WARNING: if the boards do not have all the I/O needed for the selected configuration, wizard will signal error and users can decide if to continue or modify configuration.

```
Wizard End Ib4a  
WARNING: Problem(s)  
occurred during  
I/O auto-configuration  
[ENTER]continue anyway  
[ESC]return to begin.  
[DOWN]more information
```

**WATCH OUT!!!**  
**SYSTEM OF UNIT MEASUREMENT CANNOT BE CHANGED**  
**AFTER WIZARD! METRIC (SI) OR IMPERIAL (US)**

# Wizard Step by Step

```
Language Fb01
Language: ENGLISH
[ENTER] to change
[ESC] to skip
5
```

```
Start up
Select config.item:
WIZARD
Answer the questions
to have a fully
configuration
```

```
Wizard Ib01
Type of installation:
SUCTION & CONDENSER
Regulation Type:
BOOSTER TRANS.
```

```
Wizard Ib02
Measure units:
°F/psig
```

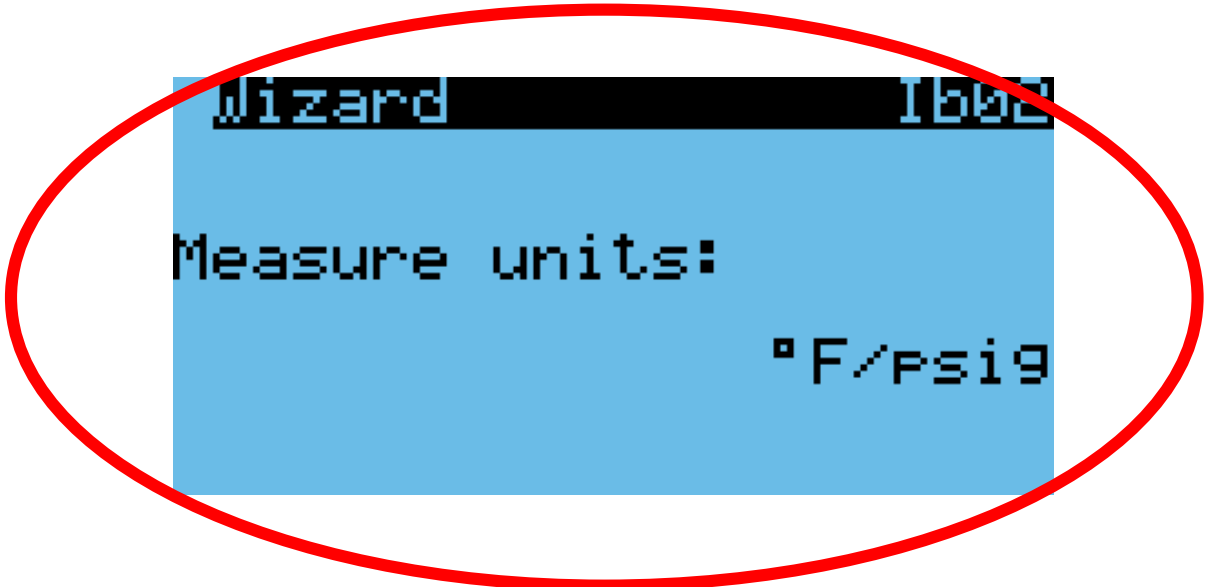

# After the Wizard...

By going to *main menu* -> *inputs/outputs* -> *status* -> you can configure all of the inputs and outputs.

```
L1-DI Status      Baa56
Common low Pressostat
PLB [1]          ID --
Status           Close
Logic            [NO]
Function        Not active
```

```
L2-AI Status      Bab05
Suction Press.Probe
PLB [1]          U2      0-5V
-39.43psig
Upper value: 185.0psig
Lower value: -14.5psig
Calibration: 0.0psig
```

```
DO Status         Bac02
Compressor 1
PLB [0]1
Line relay DO-- Off
Logic             [NO]
```

```
AO Status         Bad07
Fans inverter
PLB [1]          AO --
Status           0.0%
```

**Watch out! Some I/O can be accessed from multiple menus OR only from one menu!**



# Regulation & Rotation

# Regulation & Rotation

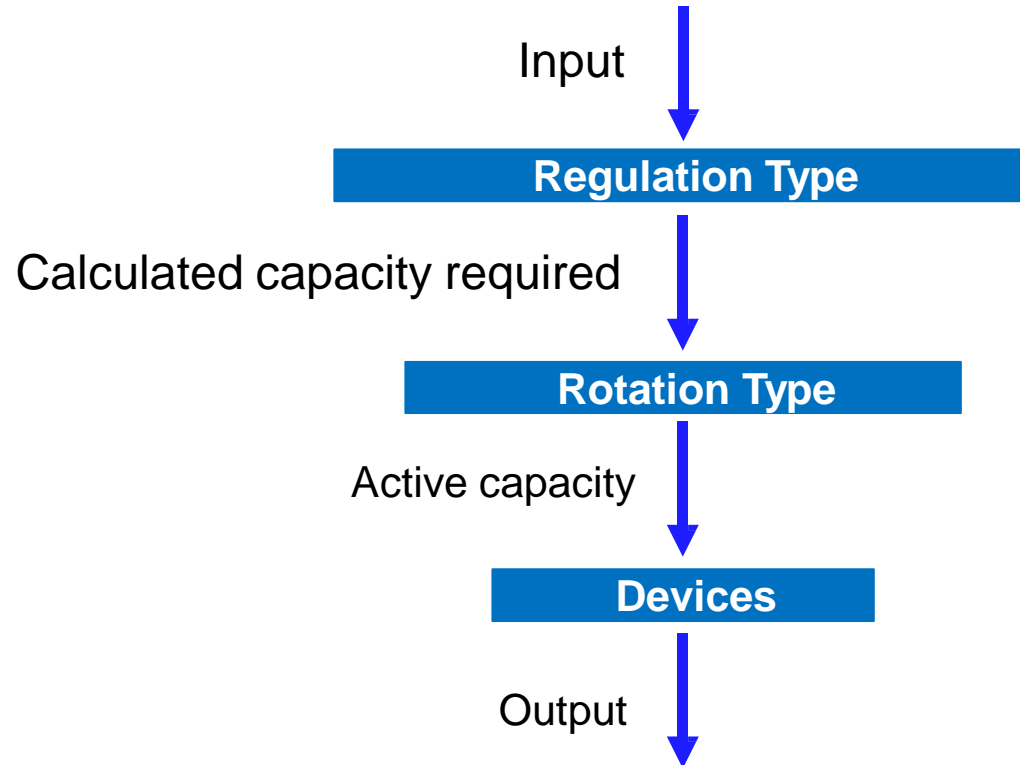

## Regulation Type

- Neutral zone, proportional band, proportional & integral band

## Rotation Type, Timings, etc.

- FIFO, LIFO, Running time, custom
- Variable speed comp is ALWAYS first on, last off.
- Modulating devices ramp down as stages increase, providing a full spectrum of system capacity.

## Devices Controlled

- Compressors, fans

# Regulation: Neutral Zone 1/3

## Neutral Zone:

Used for both compressors and fans

## A central zone in which:

- Compressors/fans are not activated or deactivated
- Central set point with differential on both sides
- Timings of starting and stopping
- **Variable speed devices ARE modulated within this zone**

# Regulation: Neutral Zone 2/3

The required capacity depends on:

- setpoint
- Differential - your parameter is NOT divided by 2!
- activation band
- deactivation band

Outside of these zones, the required capacity reaches the maximum (100%) or minimum (0%)

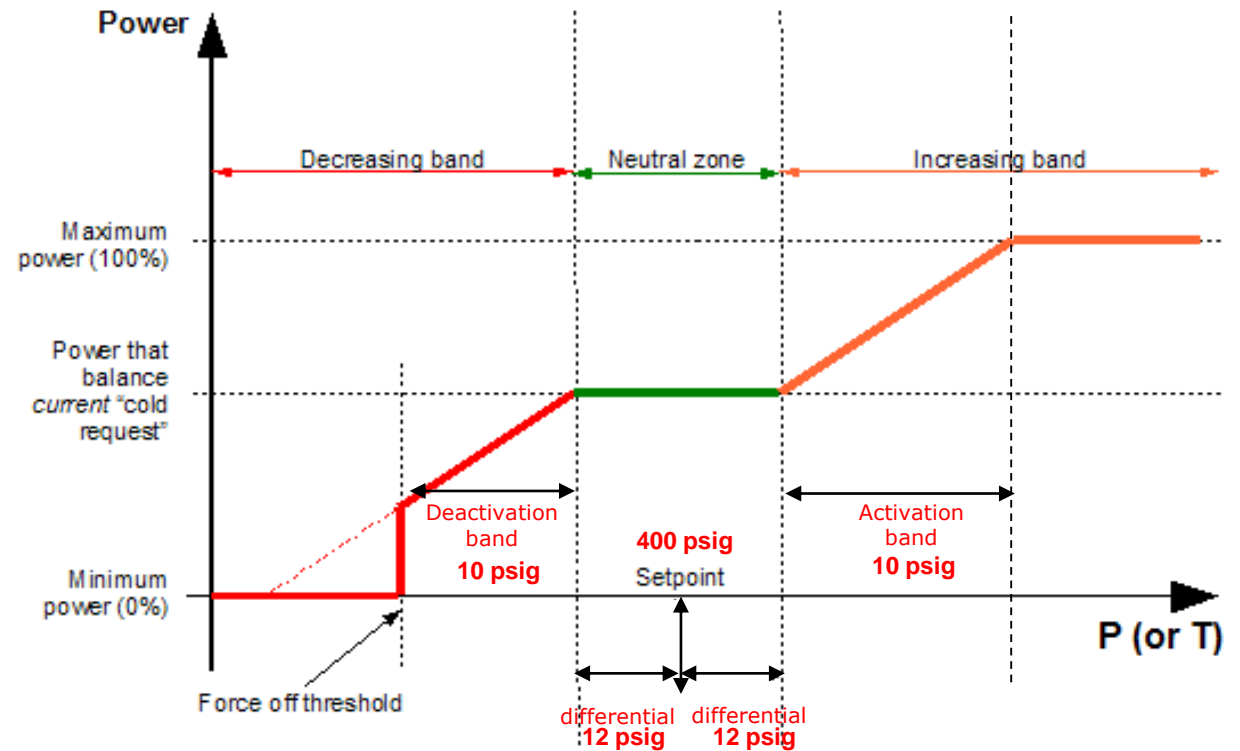

***Narrow bands = fast and reactive systems, possible swings***

***Wide bands = slow and stable systems***

# Regulation: Neutral Zone 3/3

Based on the current system operating point, the required CAPACITY the controller is calling for (remember, this is NOT the # of compressors) depends on TIMINGS. Since the controller is looking at the total capacity, the timings you enter are TOTALS, and therefore divided by the # of compressors you have.

## Activation Zone (“Power load...”)

- Minimum activation time from 0 to 100%
- Maximum activation time from 0 to 100%

## Deactivation Zone (Power unload...”)

- Minimum deactivation time from 100 to 0%
- Maximum deactivation time from 100 to 0%

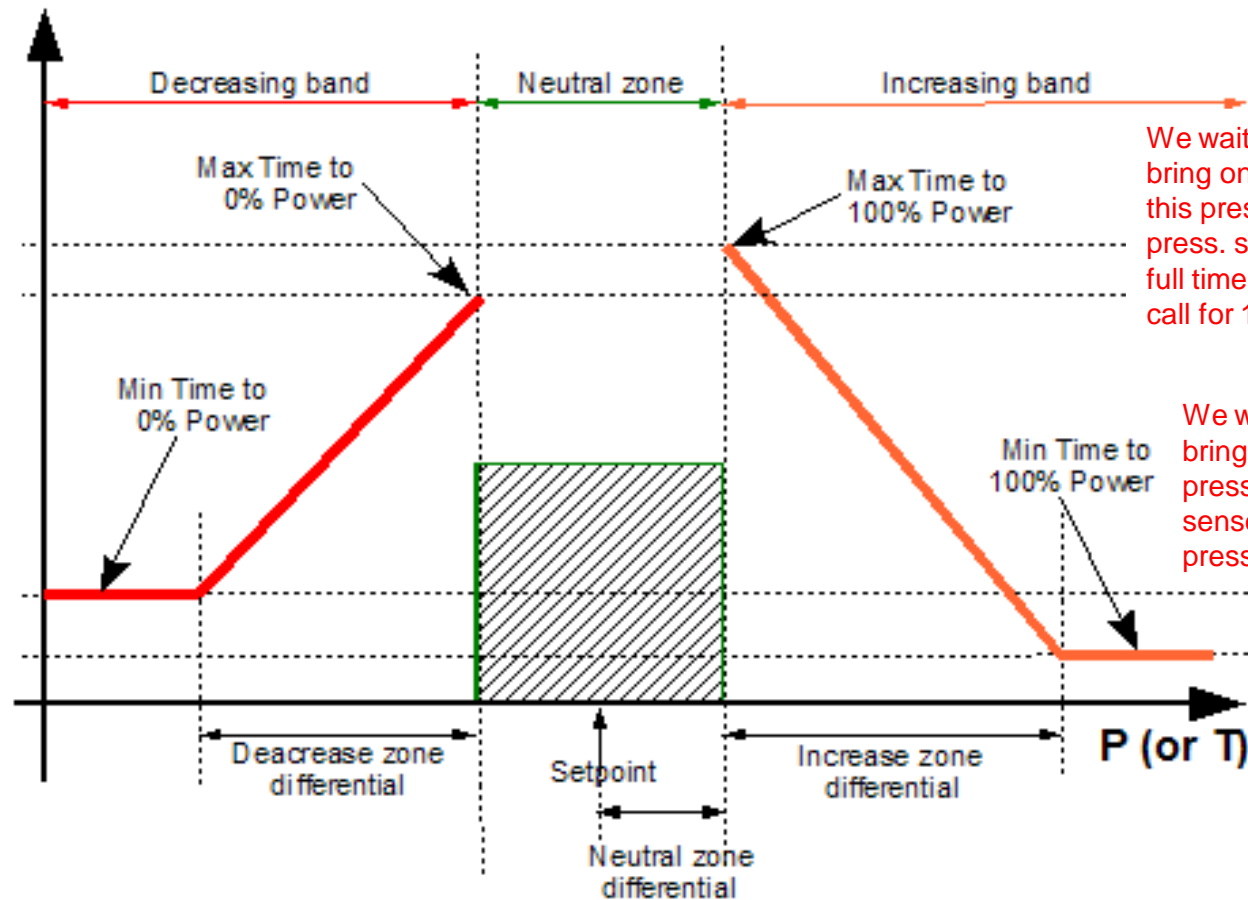

Based on the specific configuration of compressors or fans (number, sizes, etc.) the activation/deactivation times of the different compressors depend on how far the value is from the set point.

# Regulation: Prop.+ Integral Band

Required capacity depends on the proportional and integral (adjustable).

Parameters:

- Setpoint
- Differential (this won't be divided by 2!)
- Time (in seconds)

***High Differential (psig) = system slow and not reactive***

***Low Differential (psig) = system fast and reactive, possible instability***

***High Integral Time (seconds) = system slow to respond to instability***

***Low Integral Time (seconds) = system fast and reactive, possible instability***

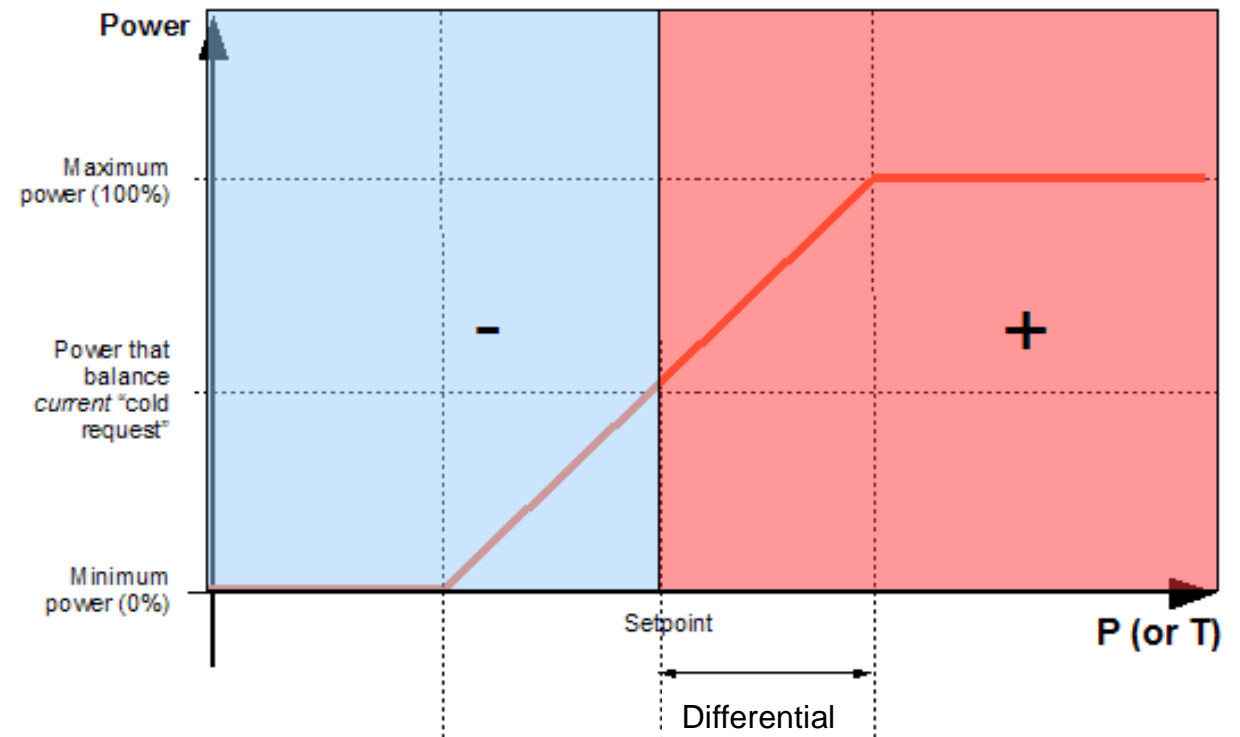

# Rotation

Part of the SW that reads the power capacity request from the regulation and tries to activate the right type or number of devices to make the active capacity as close as possible to the capacity request... **In other words, lets match what we have to what we need.**

## Uses:

- Rotation type. FIFO, LIFO, running time, custom
- number and type of device available
- actual status of devices
- timings
- alarms
- sequence of activation and deactivation

## Required capacity refers to:

- 0% = all available compressors off
- 50%= half of available compressors on
- 100% all available compressors on

# Rotation of Variable Capacity Compressors

The rotation manages the activation of the **speed modulating device** considering

- minimum activation (min frequency)
- maximum activation (max frequency)
- nominal capacity
- nominal frequency
- increase and decrease times

The management is the same in case of:

- inverter
- digital scroll

```
Comp.Advan.   Cag01
Inverter configuration
Minimum voltage:  0.0V
Maximum voltage: 10.0V
Nominal freq.:   50Hz
Nominal power:   10.0Kw
```

```
Comp.Advan.   Cag02
Inverter configuration
Rising time:     20s
Falling time:    10s
```

```
Comp.Config.  Caf16
Inverter configuration
Min.frequency:   30Hz
Max.frequency:   60Hz
```

Min/Max voltage should “match” Min/Max frequency. In other words, if you want 2.5V (25%) as your minimum voltage, then your minimum frequency should be 15Hz (25% of 60Hz).



# Rotation – An Example

Comp 1: 30-60kW = 8.5-17T (102-205MBtu)

Comp 2: 20kW = 5.7T (68MBtu)

Comp 3: 20kW = 5.7T (68MBtu)

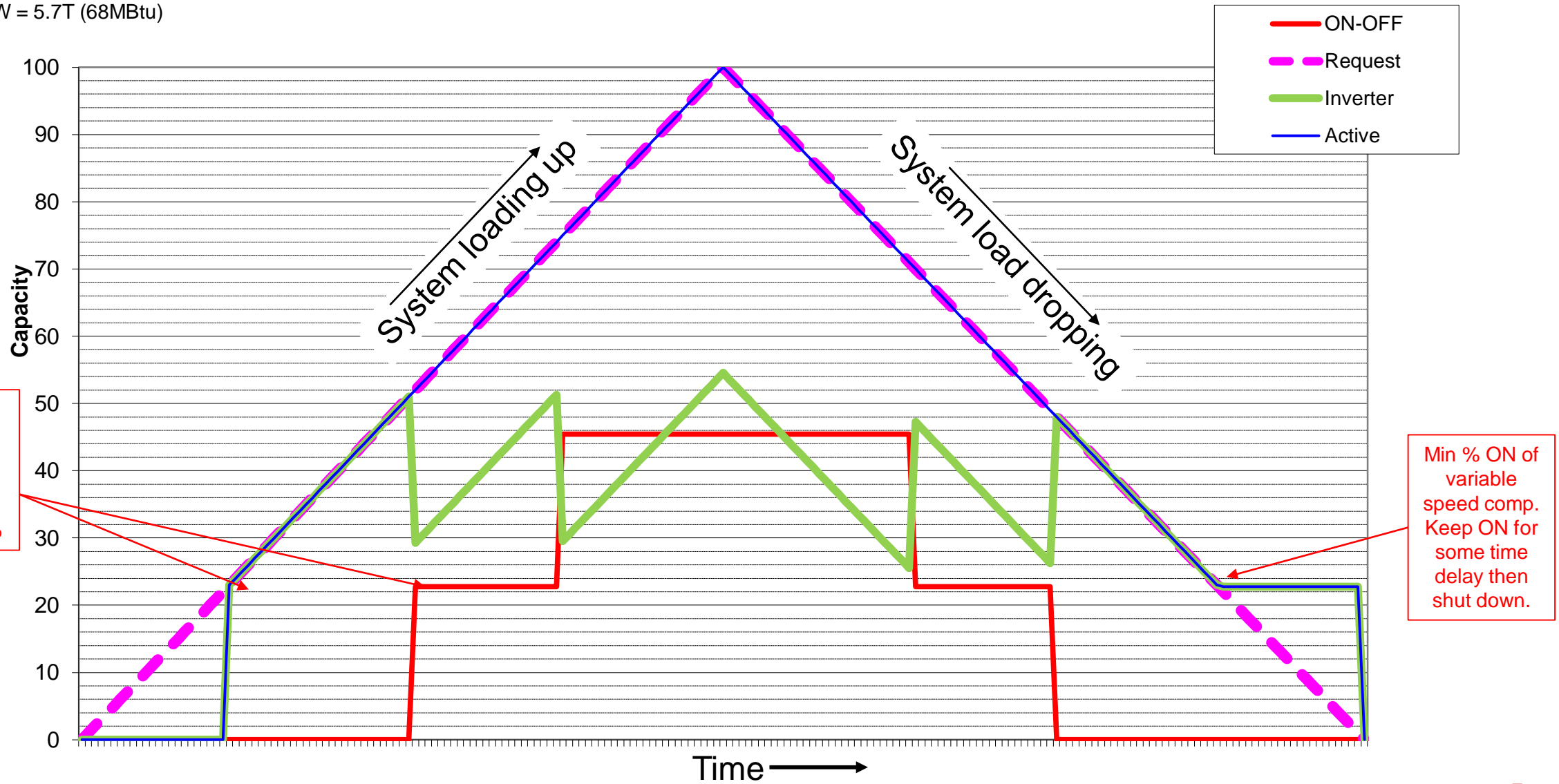

# Compressor Alarms

# Main Alarm Steps

		<i>Example of value for MT side</i>
HP Pressostat Switch	→	115 barg (define by OEM)
HP Gas Cooler Alarm (by probe)	→	110 barg
Prevent	→	107 barg
P100%	→	106 barg
Pmax		103 barg
HPV Setpoint	→	
Min HPV Setpoint	→	50 barg
Low GC pressure alarm	→	20 barg
Comp. regulation Setpoint	→	26 barg
Cut-OFF/Pump-down	→	22 barg
Low Suction Pressure Alarm	→	20 barg
LP Pressostat Switch	→	18 barg (defined by OEM)



The bookends in the setting of software thresholds are:

- HP Pressure Switch
- LP Pressure Switch

# Compressor Safety

- Compressors have individual alarms: Overload, Oil, H.P., L.P. and Generic.
- System Alarms: System HP, LP, Oil, Liquid Level, Inverter fault.
- Suction Superheat alarm: By strapping an NTC sensor to the compressor inlet, the pRack can monitor floodback. It can be set to turn the system off in the event of low superheat.
- H.P. Prevent feature: The pRack can be set to prevent the system from going off due to high discharge pressure.
  - At a preset pressure the controller will engage heat reclaim (if configured), then it will begin unloading the Rack to prevent shutdown. Additional measures also taken within programming dependent upon configuration.
- **Anti Liquid Return feature: if no compressor is operable, the anti liquid return relay remains disabled.**

# pR300T: Compressor Alarms

## Piston or scroll compressors:

- maximum 4 alarms (DI) per compressor
- Generic, HP, LP, overload/Klixon, oil
- the alarms can be grouped as desired on the same DI: 2 digital inputs
  - ID1 = HP+LP
  - ID2 = overload/Klixon + oil
- **What the heck does this mean? All you're doing is grouping the alarms for display purposes**

## Common features

- All alarms can have automatic or manual reset
- All alarms are enabled also if compressor is off
- All alarms have start up delay and activation delay
- Start-up delay is reset at every switch on of the compressor
- Settable priority of alarms: SERIOUS – WARNING, activation of different alarm relays
- Only two different alarms to supervisor SERIOUS – WARNING, description of alarms is conveyed by dedicated variable.

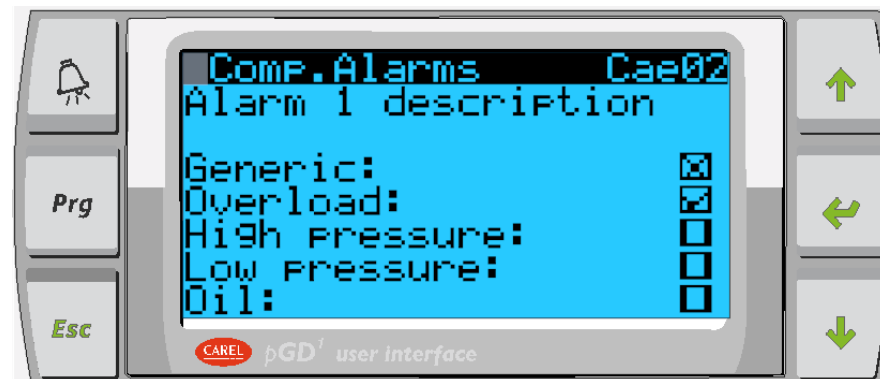

# pR300T: Compressor Alarms

```
L1-Comp.Alarms Cae01
Number of alarms
for each compressor:
1
```

- Up to 4 alarms by DI can be configured for each compressor

```
L1-Comp.Alarms Cae02
Alarm 1 description
Generic:
Overload:
High Pressure:
Low Pressure:
Oil:
```



**Watch out! Look closely...there are check marks and "X's"!!**

- For each alarm it is possible to associate the description

```
L1-Comp.Alarms Cae04
Alarm 1
Activ.delay: 0s
Start up delay: 0s
Reset: AUT.
Priority: SERIOUS
```

- Configure the delay, type of reset (auto or manual) and Alarm Digital Output (Serious or normal). Alarm code: from ALC90 to ALC99

# pR300T: Compressor Alarms

```
L1-Comp.Alarms Cae24
Suction high
Pressure
alarm:          ABSOLUTE
Threshold:      35.0barg
```

- High Suction pressure alarm by probe (threshold and type threshold: ABSOLUTE or RELATIVE)

```
L1-Comp.Alarms Cae25
Suction high
Pressure
alarm diff.     1.0barg
Alarm delay:    120s
```

- Alarm will be issued at pressure > 35 barg and it will be reset at 34 barg.
- **This alarm forces the compressors at max power**

```
L1-Comp.Alarms Cae41
High discharge
pressure alarm
Threshold:      110.0barg
Diff.:          5.0barg
Alarm delay:    0s
```

- High Discharge pressure Alarm by probe (threshold, differential and delay).
- This mask appear ONLY if a discharge pressure probe has been configured.
- **This alarm forces OFF the compressor.**

# pR300T: Compressor Alarms

```
L1-Comp.Alarms Cae42
Low discharge
pressure alarm

Threshold:    44.0barg
Diff:        5.0barg

Alarm delay:    0s
```

- Low Discharge pressure Alarm by probe
- This mask appear ONLY if a discharge pressure probe has been configured.
- **This alarm does not do any actions**

```
L1-Comp.Alarms Cae29
Low superheat alarm
Enable:      ONLY ALARM
Threshold:   3.0K
Alarm diff.: 1.0K
Switch off comp.: NO
Reset:      MANUAL
Alarm delay: 30s
```

- Low SH alarm: disabled, ONLY ALARM, or WARNING + ALARM
- **Alarm:** Low SH with Comps running (delay will be **Alarm delay**).
- **Warning:** Low SH with Comps running (delay will be **half of Alarm delay**)

```
L1-Comp.Alarms Cae40
Warning inverter

Switch-off comp.1: NO

Reset:      MANUAL

Alarm delay: 0s
```

- Warning Inverter Alarm



# Gas Cooler Control

# Gas Cooler Control

- Fan operation can be tied directly to compressor operation or as stand alone devices.
- Fans may be managed with LIFO, FIFO, Time, or custom rotation in the same way as the compressors.
- **Controlled by Gas Cooler Outlet temperature in current applications.**

<pre>G.Cooler.Reg. Dab01 Regulation by:                 TEMPERATURE Regulation type:                 PROPORTIONAL BAND</pre>	<pre>G.Cooler.Reg. Dab02 Setpoint limits Minimum:        5.0° C Maximum:       25.0° C</pre>
<pre>G.Cooler.Reg. Dab03 Setpoint:       25.0° C</pre>	When outlet at this temperature fans are running 100%

# Fan operation with modulating device

Fans can be controlled by a modulating device.

Parameters can be set on screens Dag02 and Dbg02

Minimum modulating output value 0 V, maximum value 10 V, or vice versa

Minimum modulating device capacity 0 %, maximum 100 %.

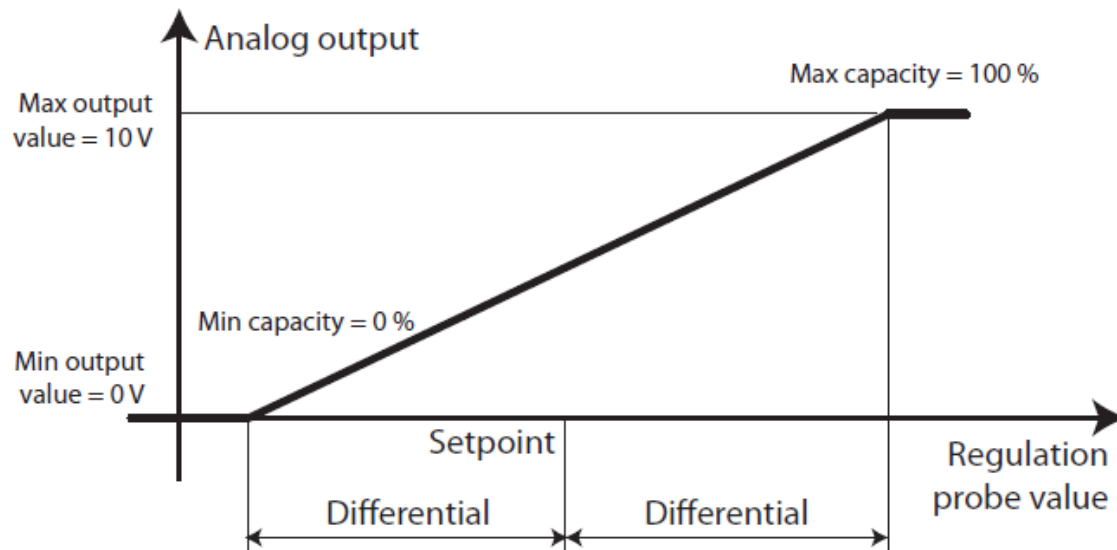

**Reversing Max/Min power refer. will change the output to a 10 – 0 Vdc signal**

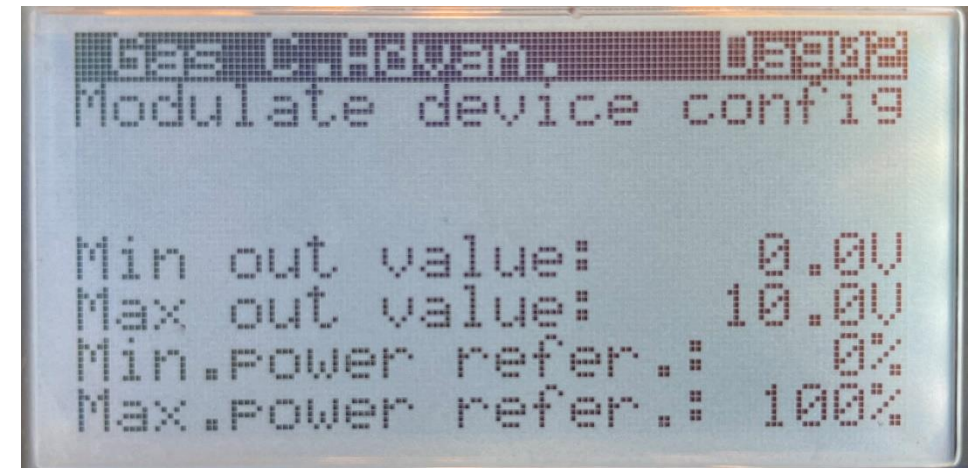

# High Pressure Prevention

- Controller does what it can to prevent high pressure switch from tripping

**Prevent** procedure to avoid high condensing pressure alarm

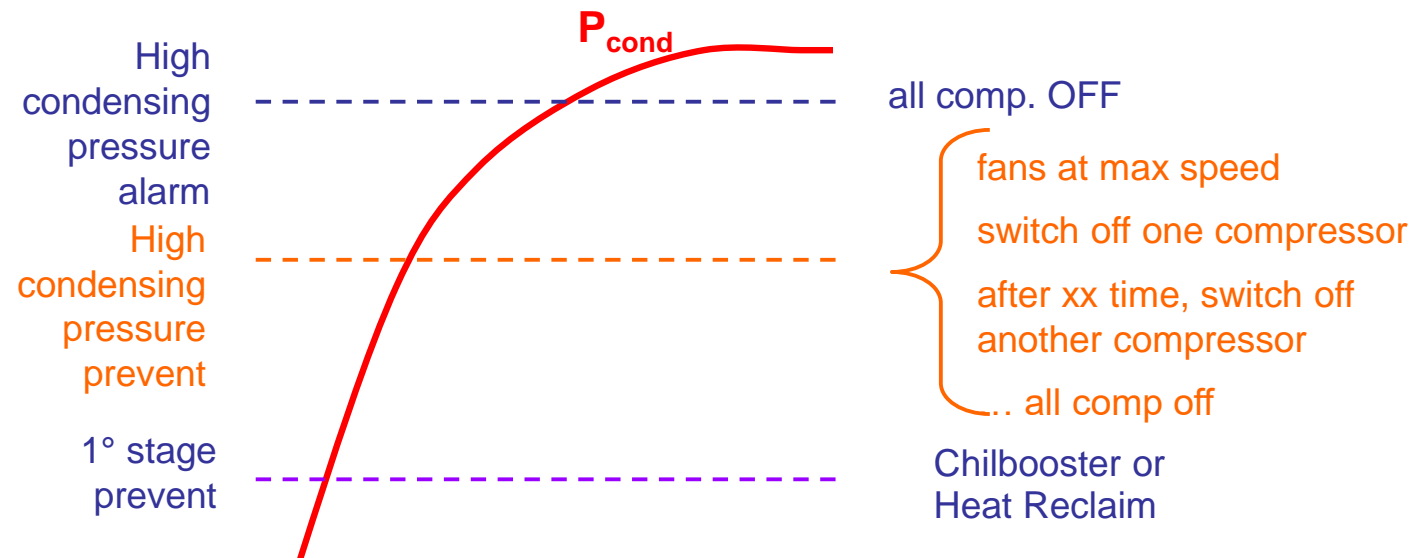

In case there are heat reclaim or chillbooster, they can be used as first stage of prevent.

# pR300T: Gas Cooler Alarms

```
Gas C.Alarms  Dae01
Gas cooler
Pressure
high alarm:  ABSOLUTE
Alarm delay:  60s
```

- High Gas Cooler pressure alarm by probe (threshold and type threshold: ABSOLUTE or RELATIVE)

```
Gas C.Alarms  Dae06
High gas cooler press.
alarm thr.:  110.0barg
Alarm diff.:  5.0barg
```

- **This alarm force the GC fans at max power and shut off the compressors**

```
Gas C.Alarms  Dae03
Gas cooler
Pressure
low alarm:  ABSOLUTE
Alarm delay:  30s
```

- Low Gas Cooler pressure Alarm by probe
- This mask appears ONLY if discharge press probe is configured.
- **This alarm does not do any actions**

```
Gas C.Alarms  Dae05
Common fan overload:
                YES
Delay:          30s
Reset:         MANUAL
```

- Fan Common Overload by DI
- YES: only one common overload available and NO action to fans in alarm state
- NO: can be configured an Overload DI for each Fan.
- The Fan1 Overload shuts off the fan output only if it is not common with other fans

# High Pressure Valve (HPV)

# How do we drive valves?

**pR300T CO<sub>2</sub>** can control HPV/RPRV (Flash Gas Bypass) valves via an EVD Evo driver, an onboard driver, or via a 0 -10Vdc signal.

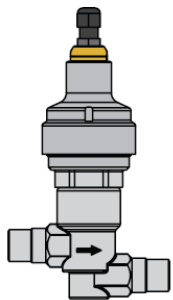

CCMT

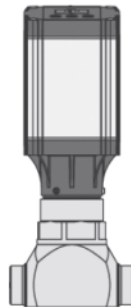

ICMTS



 **built-in driver**  
with Ultracap Tech.

0 – 10Vdc Flash Gas Bypass

0 – 10Vdc HPV

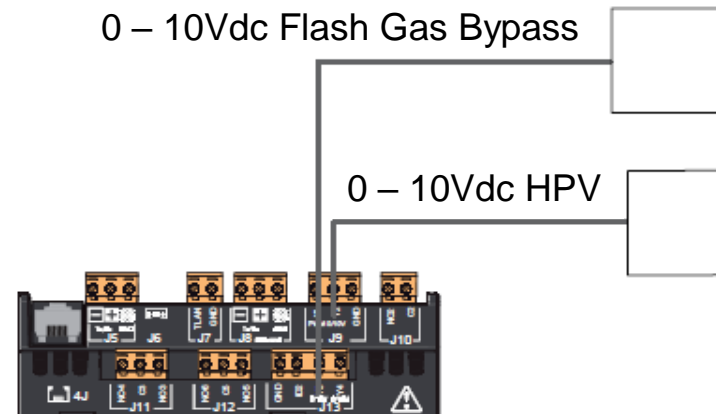

# Transcritical CO<sub>2</sub> cycle

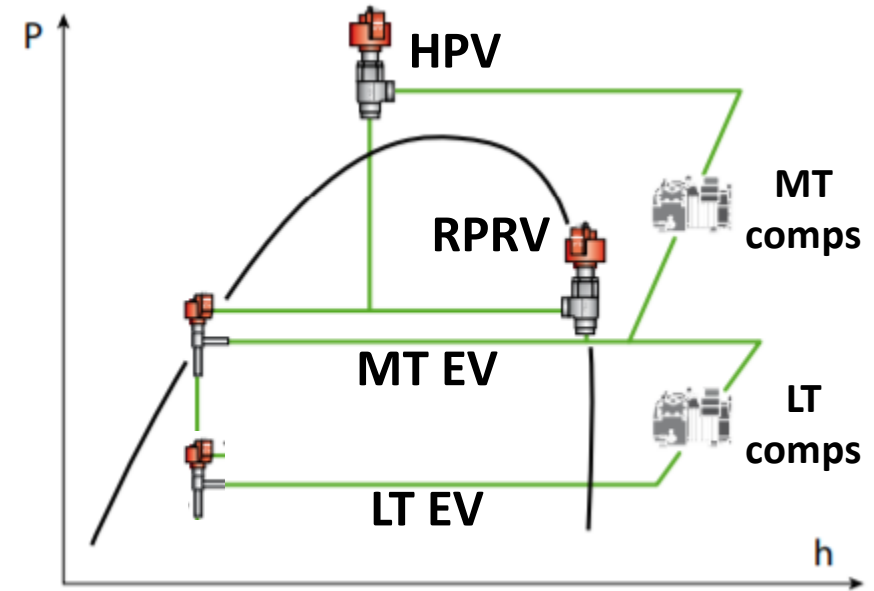
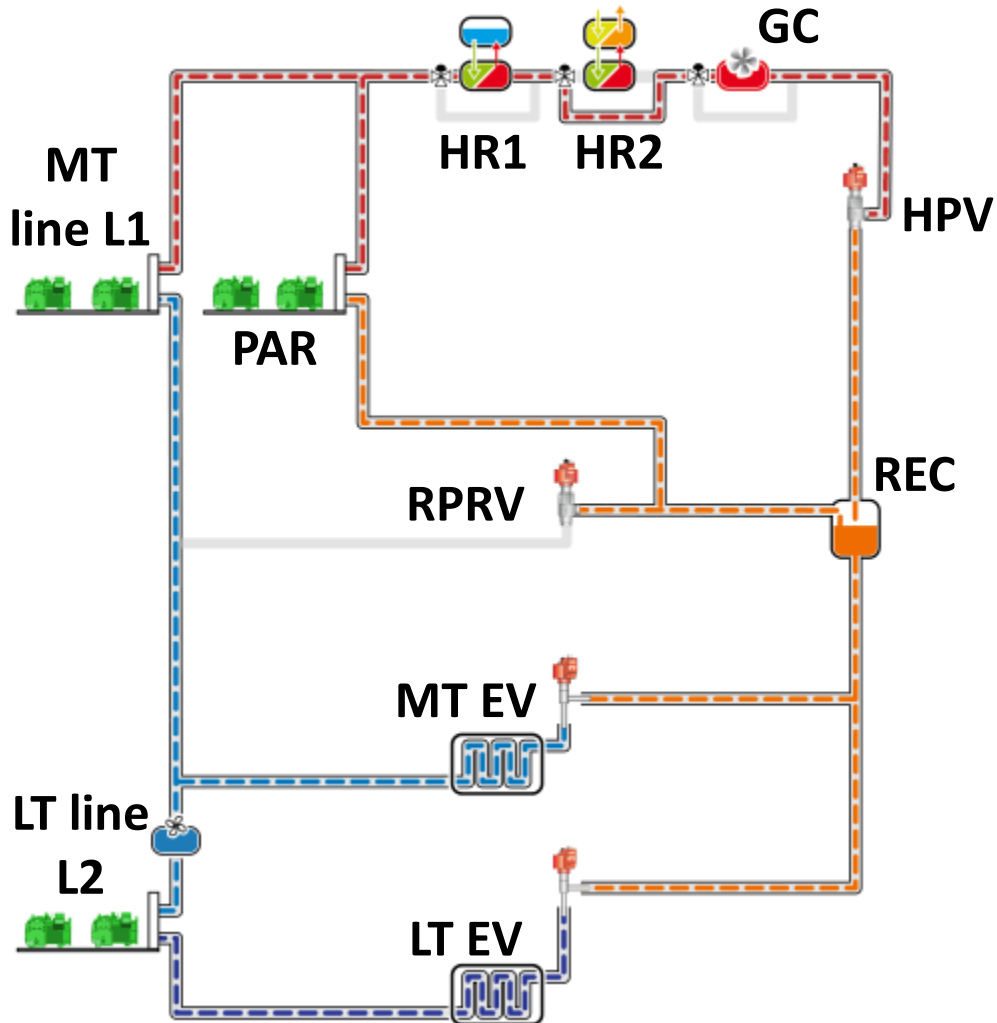

## CO<sub>2</sub> specific components

- **Gas cooler:** equivalent of condenser, so called because in transcritical conditions there is no condensation but gas cooling
- **High pressure valve (HPV):** controls gas cooler pressure
- **Receiver pressure regulation valve (RPRV):** also called flash gas valve, controls receiver pressure
- **Optional - Parallel compressor:** controls receiver pressure in behalf of the RPRV



# High Pressure Valve management

- HPV managed according to the zone identified based on Gas Cooler outlet temp and gas cooler pressure
- Minimum gas cooler pressure, less compressor work
- Adjustable limits, speed, standby, and backup positions of the HPV
- Alarms for troubleshooting and monitoring

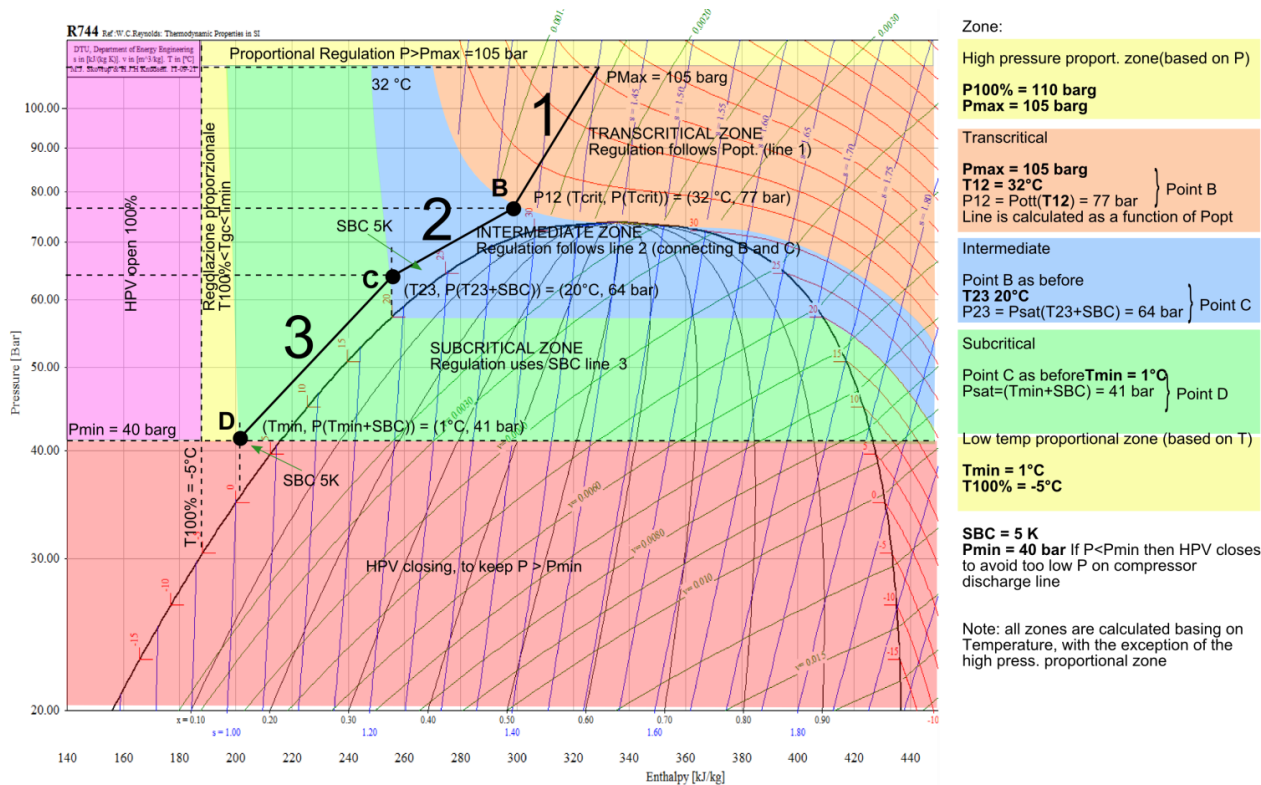
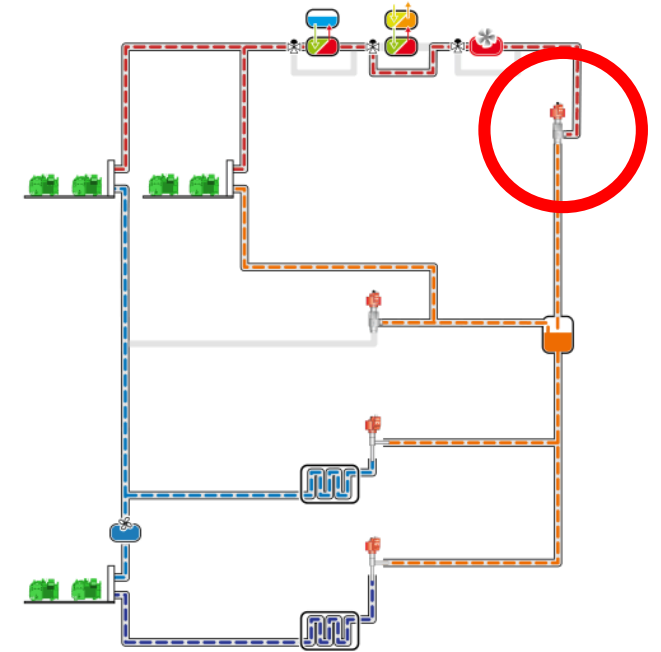

## 1. Transcritical Zone

Calculation of the optimal Gas Cooler pressure to maximize COP.  
PI regulation to keep HPV pressure optimal setpoint

## 2. Intermediate Zone

PI regulation for a smooth transcritical to subcritical transition

## 3. Subcritical Zone

PI regulation of the HPV valve to keep a subcooling setpoint

## Safety zone

Above a set pressure the HPV valve open proportionally to avoid pressure increase

# Transcritical Settings (HPV)

```
Trans.Settings Eib001
Enable HPV valve
management:      YES
Setpoint calculation
algorithm:       CUSTOM
```

- Enable/disable HPV management.
- Setpoint calculation is CUSTOM and cannot be modified.

```
Trans.Settings Eib002
Min.HPV opening Perc.
During ON:       0.0%
during OFF:     0.0%
```

## Minimum Opening %:

- **During ON:** while the UNIT is ON (by parameters, DI or supervisor)
- **During OFF:** while the UNIT is OFF (by parameters, DI or supervisor)

```
Trans.Settings Eib003
Max.HPV valve opening
percentage:     100.0%
Max.delta:     10.0%
```

- Max opening percentage that can be taken on by HPV valve during the regulation (while the UNIT is ON).
- **Max delta** Max allowed variation of the valve position in one shot.

# Transcritical Settings (HPV)

```
Trans.Settings Eib03
HPV value
Pre-pos.value: 50.0%
Pre-pos.time: 5s
```

- Prepositioning of HPV valve after that unit enters in ON status.
- HPV valve remains at a fixed position for the pre-positioning time.
- *This procedure is reactivated whenever the unit goes into OFF status or the HPV valve moves into the minimum position due to all compressors being turned off (optional).*

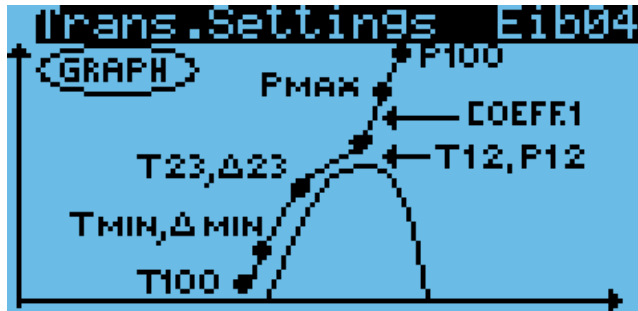

- Graph that summarize the different regulation zones of HPV valve.

```
Trans.Settings Eib05
Graph design
P100%: 109.0barg
Pmax: 104.0barg
Pcritic: 82.0barg
T12: 31.0°C
T23: 20.0°C
Tmin: 6.0°C
```

- Modify each regulation zone of HPV valve.

# Transcritical Settings (HPV)

```
Trans.Settings Eib06
Graph design
T100%:          -10.0°C
Delta:           3.0°C

Lines design
Coeff.1:         2.5
```

- “**Delta**” is the subcooling used by the system to calculate the setpoint in the subcritical zone.
- “**Coeff.1**” is the line design ratio. By decreasing the ratio, with the same Tgc\_out, the optimal HPV setpoint will decrease.

```
Trans.Settings Eib07
PI regulation

P1:              5%/barg
I1:              60s
```

- Proportional and Integral time used to control the HPV.
- Proportional identifies the HPV valve opening variation for every 1 barg change in the Gas Cooler pressure.

```
Trans.Settings Eib08

Enable HPV setpoint
filter:          NO

Number of samples: -
```

- Filter that can be enabled to avoid fluctuations in the Gas Cooler pressure. Could be used to correct any electromagnetic noises presented in the GC\_Out\_temperature.

# Transcritical Settings (HPV)

```
Trans.Settings Eib28
Maximum HPV safety
setpoint:      90.0barg
Minimum HPV
setpoint:      40.0barg
Enable low temperature
control:       NO
```

- **Max HPV safety setpoint:** max allowed value other functions try to increase the setpoint (protections of the receiver pressure by HPV). In normal operating conditions this can be up to Pmax (Fhb25).
- **Min HPV setpoint:** min value allowed in running mode.
- **Enable low temperature control** enable the Low temp proportional zone.

```
Trans.Settings Eib10
Safeties
Safety HPV valve
position:      50.0%
```

- Safety position of HPV in case of some fault (broken Gas Cooler outlet temp. probe or broken Gas Cooler pressure probe)

```
Trans.Settings Eib11
Safeties
Delta temp.
with gas cooler
probe error:   3.0°C
```

- Offset to add to the External Temperature reading in case of Gas Cooler temp. probe error.
- **Auto switch on ext. temp. must be enabled on mask Dag14.**

```
Gas C.Advan.   Dag14
Enable gas cooler
press.backup probe:
                                                         NO
Auto switch ext. temp.
if GC. probe fault:
                                                         YES
```

# Transcritical Settings (HPV)

```
Trans.Settings Eib12
Safeties
Enable HPV safeties
by receiver Press.:
                    YES
```

- Parameter to enable some actions in the HPV valve to prevent High and Low pressure conditions in the receiver (see masks Eib13 and Eib14)

```
Trans.Settings Eib13
Safeties
High receiver pressure
threshold:      60.0barg
Max receiver pressure:
                70.0barg
Incr.set.HPV:  10.0barg
```

- If the receiver pressure will rises above the threshold, a proportional offset will be added to the HPV setpoint in order to close the HPV. **For example: start at a 0 bar offset @60barg and scale up to a max 10 bar offset @70barg.**

```
Trans.Settings Eib14
Safeties
Low receiver pressure
threshold:      35.0barg
Min receiver pressure:
                29.0barg
Decr.set.HPV:  10.0barg
```

- If the receiver pressure falls below the threshold, a proportional offset will be subtracted to the HPV setpoint in order to open the HPV. **For example: start at a 0 bar offset @35barg and scale up to a max 10bar offset @29barg.**

```
Trans.Settings Eib15
Safeties
Force closing when
compressor OFF:  NO
Closing delay after
compressor OFF:  10s
```

- Parameter to **enable** closure of HPV when compressor is OFF. The HPV closing position will match the value set as min HPV position during OFF.
- **Delay** to close the HPV valve after the compressor switch OFF.

# Flash Gas Bypass Valve

(RPRV, Receiver Pressure Regulating Valve)

# Transcritical Settings (Flash Gas Bypass)

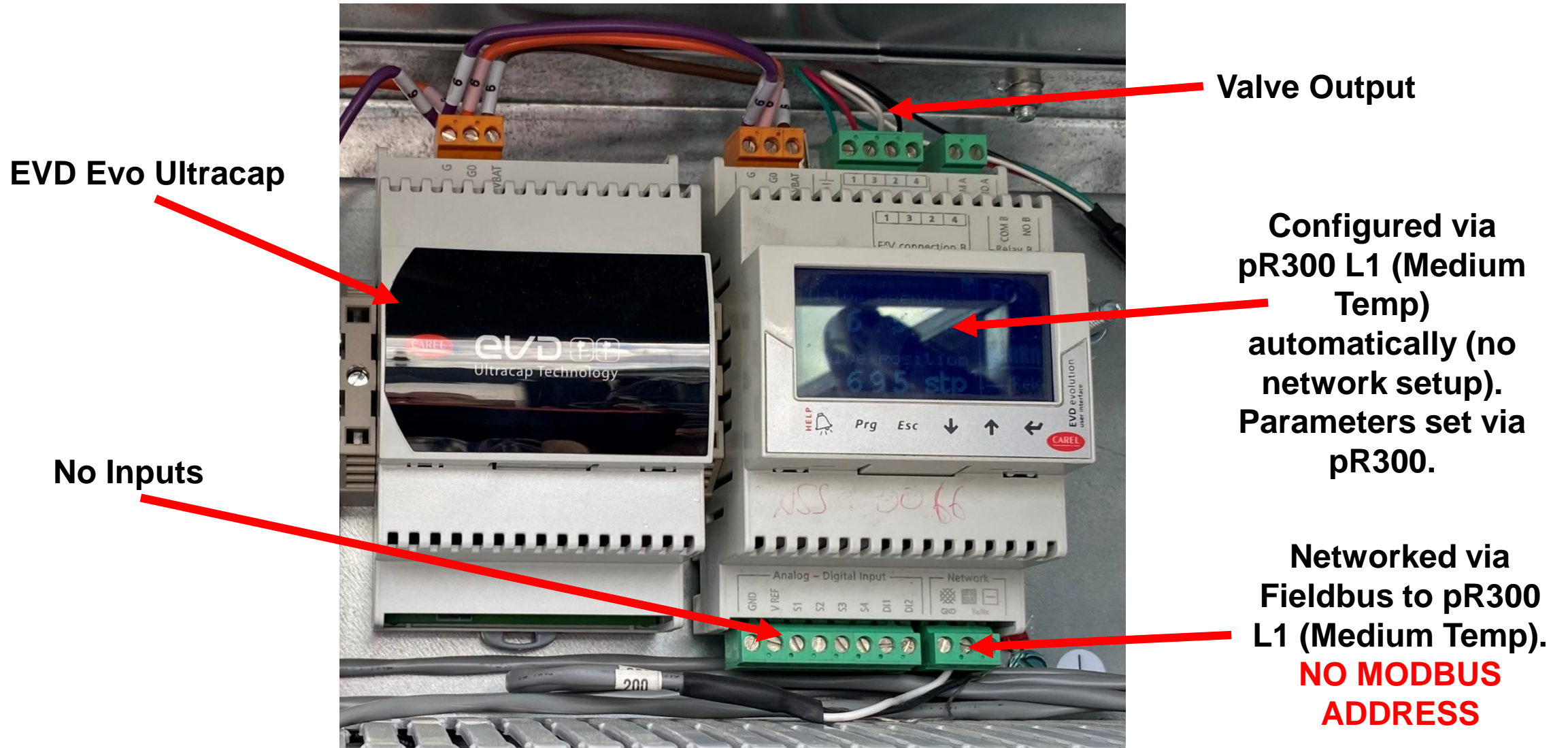



# Receiver Pressure Regulation Valve management

- **PI regulation** to maintain receiver pressure at settable setpoint
- **Settable limits**, speed and stand-by and backup positions of the valve
- **Debug** and monitoring alarms
- High and low receiver pressure **safety functions**
- High receiver pressure **alarm cut off compressors**
- Embedded algorithm with 0-10V output, **compatibility with all kind of valve in the market** using EVD EVO driven by 0-10V input
- **Backup/integration function of a secondary RPRV valve**

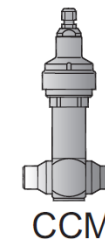
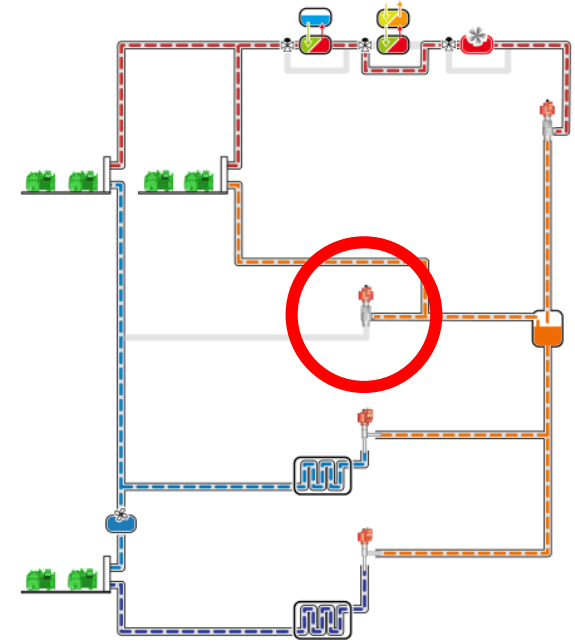

CCM



# Transcritical Settings (Flash Gas Bypass)

```
Trans.Settings Eib18
Enable RPRV valve
management:          YES
```

- Mask where it is possible to enable/disable the RPRV management.

```
Trans.Settings Eib19
Min.RPRV opening Perc.
during ON:           0.0%
During OFF:          0.0%
```

- Min. opening percentage that can be taken on by RPRV:  
During ON: while the UNIT is ON (by parameters, DI or supervisor)  
During OFF: while the UNIT is OFF (by parameters, DI or supervisor)

```
Trans.Settings Eib20
RPRV valve
Pre-pos.value:      50.0%
RPRV valve
Pre-pos.time:       5s
Start from prepos: NO
```

- Prepositioning of RPRV valve after that unit enters ON status. RPRV valve remains at a fixed position for the pre-positioning time.
- *This procedure is reactivated whenever the unit goes to the OFF status or the RPRV valve moves into the minimum position due to all of the compressors being turned off (optional).*

# Transcritical Settings (Flash Gas Bypass)

```
Trans.Settings E1b21
Maximum RPRV valve
opening Percentage: 100.0%
Max.delta: 10.0%
```

- Max opening percentage that can be taken on by RPRV valve during the regulation (while the UNIT is ON).
- Max allowed variation of the valve position in one shot.

```
Trans.Settings E1b22
Regulation
CO2 receiver Pressure
setpoint: 35.0barg
Prop.gain: 20%/barg
Int.time: 60s
```

- Receiver pressure setpoint (RPRV setpoint).
- Proportional coefficient and Integral time used for the RPRV. *Proportional coefficient identify the RPRV valve opening variation for every variation of 1barg in the receiver pressure.*

```
Trans.Settings E1b23
Safeties
Safety RPRV valve
Position: 50.0%
```

- Safety position of RPRV valve in case of a fault (Receiver pressure probe broken).

```
Trans.Settings E1b24
Safeties
Force closing when
compressor OFF: YES
Delay closing after
compressor OFF: 10s
```

- Enables the closure of RPRV valve when comp is OFF. *The RPRV closing position will match with the value set as min RPRV position during OFF.*
- Delay to close the RPRV valve after the compressor switch OFF.

# Transcritical Settings (Flash Gas Bypass)

```
Trans.Settings Eib25
High receiver
pressure alarm
Threshold:      45.0barg
Diff.:          5.0barg
Delay:          30s
Reset:          MANUAL
Switch off compr.: NO
```

- High receiver pressure alarm settings (threshold, differential, delay, reset).
- If “switch off compressor: NO” has been configured, no actions will be done in case of alarm.

```
Trans.Settings Eib31
RPRV Setp. comp. OFF

Receiver press.setp.
diff.:          10.0barg

Time:           60sec
```

- This mask will appear only if the “force closing of RPRV with comp. off” has been enabled (mask Eib24).
- RPRV valve will be closed only if **Receiver pressure < (setpoint+1/2 offset)** and it will stay closed until the pressure increases above **setpoint + offset**.
- As soon as the pressure reaches this value, this value becomes the new working setpoint and in 60 sec it will bring to the original value (setpoint).

Other functions

# pR300T: Double System Synchronization

- Optimization of system operation
  - To avoid simultaneous peaks on different lines (3 lines)
  - To synchronize the operation of two lines in booster systems:
1. if the low temperature line is active, then the medium temperature line must be active (forcing on compressors or pumping down compressors)
  2. if the medium temperature line cannot be active due to technical problems/faults, then the low temperature line must **not** be active

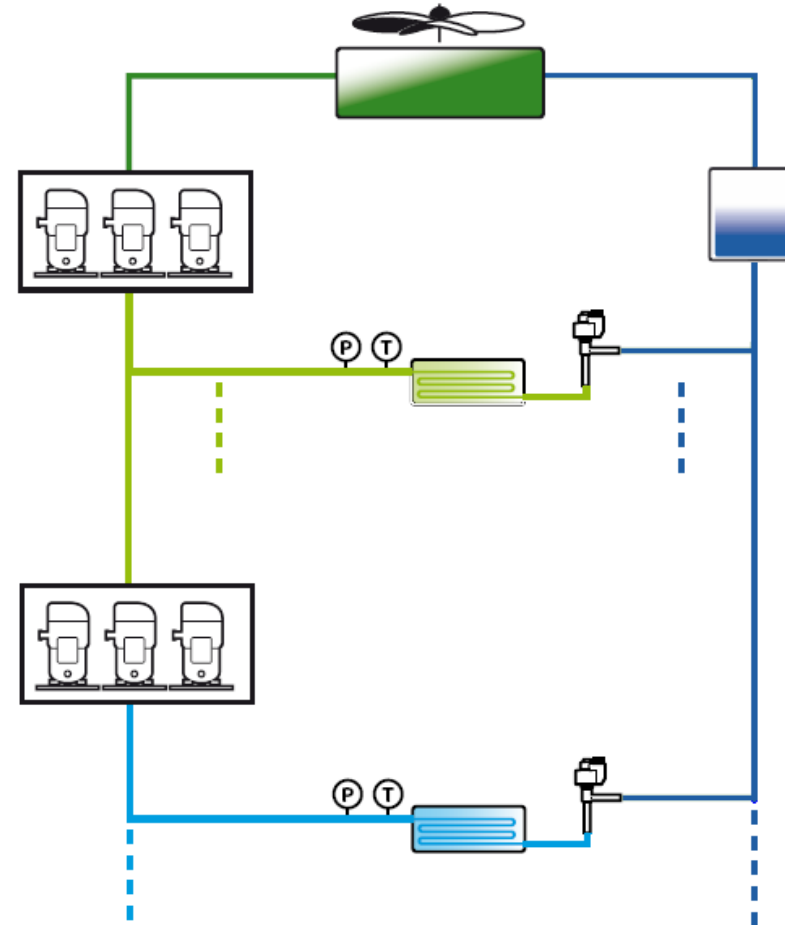

# Generic Functions

The generic functions available for each board are:

- **5 digital thermostats (ON/OFF) - DO**
- **2 modulating thermostats – AO**

**Regulation variables** can be analog inputs not used (generic probes) or internal system variables with specific threshold and differential.

**Enabling variables** can be digital inputs not used (generic DI) or internal system variables (mainly alarms).

```
Gen.Fun.Stages Efa06  
Gen.stage n.1 PLB1  
Regulation variable:  
PROBE A  
Mode: Gen.Fun.Stages Efa06  
Gen.stage n.1 PLB1  
Regulation variable:  
SUCTION.PRESS.(L2)  
Mode: DIRECT
```

```
Gen.Fun.Stages Efa07  
Gen.stage n.1 PLB1  
Enable:  
DIGITAL INPUT F  
Descr Gen.Fun.Stages Efa07  
Gen.stage n.1 PLB1  
Enable:  
AL.COND.PRESS.L(L1)  
Description: SKIP
```

# USB and RHEC Manager

*Retail High*

*Efficiency Controllers Manager*



# Connecting to pRack

RS485 Converter with telephone connector:  
**CVSTDUTLF0 to J10**

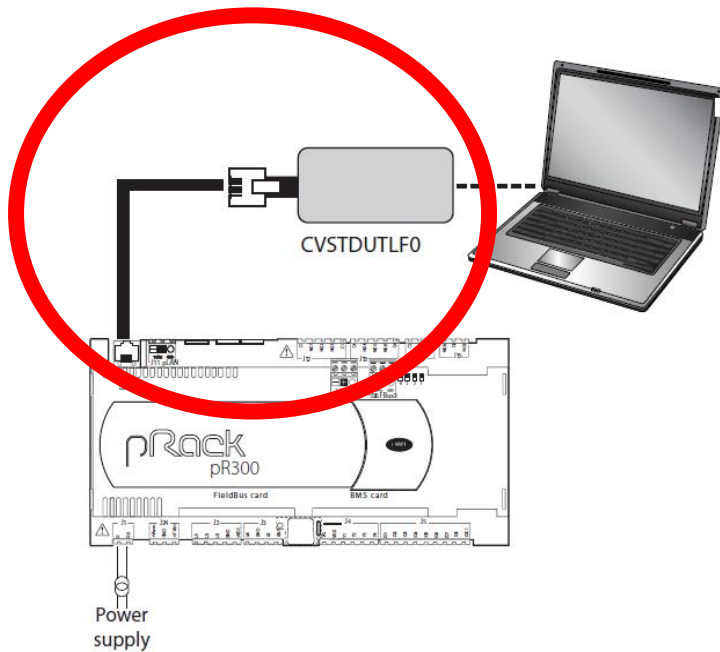

**USB-B to USB-A**  
cable to pRack

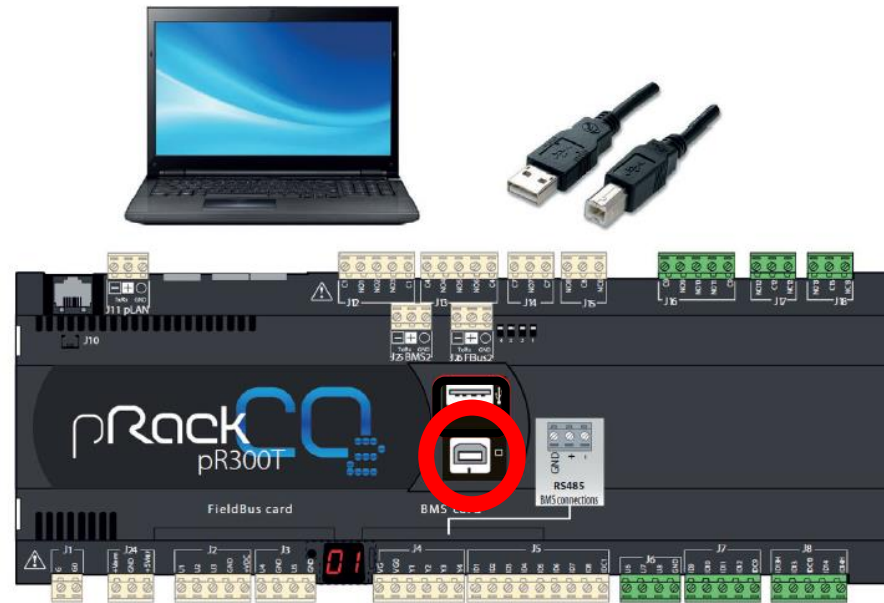

**USB drive to pRack**



# Using USB Drive – What Can You Do?

1. Download logs from controller.

2. Download/Upload the Application; AKA Software.

BKP00_01				
APPL_PCO.DWL	10/14/2001 6:25 PM	DWL File	3,328 KB	
FILE_DEV.DEV	10/14/2001 6:31 PM	DEV File	14 KB	

3. Download/Upload Parameter Settings (setpoints). This is also known as the .DEV file. Shown as “Non Volatile Memory” in controller.

DEV00_01				
FILE_DEV.DEV	11/8/2022 1:22 AM	DEV File	14 KB	

4. Download/Upload “pCO”. This is everything except logs and boot file.

CPY00_01				
APPL_PCO.DWL	11/8/2022 1:31 AM	DWL File	3,328 KB	
BIOS_PCO.BIN	11/8/2022 1:38 AM	BIN File	704 KB	
FILE_DEV.DEV	11/8/2022 1:40 AM	DEV File	14 KB	

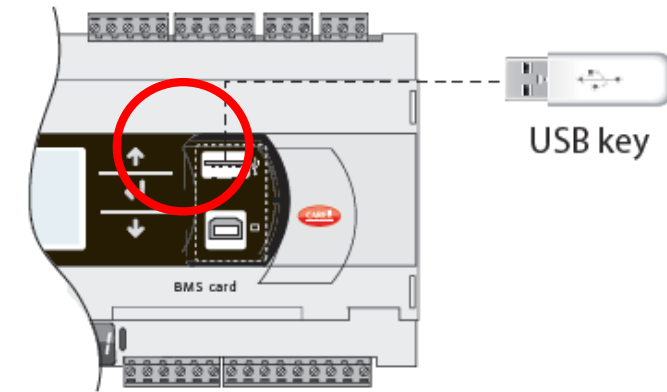

# Using USB Drive - RULES

- **File names**

In order to be recognised, the names of the directories and files on the pendrive must have no more than 8 characters; the controller makes no distinction between upper-case and lower-case characters. However, during DOWNLOAD the names of the directories created by the controller on the pendrive are always in upper-case.

- **Tested and long filenames WORK on new software! Keep directory names at 8 characters**

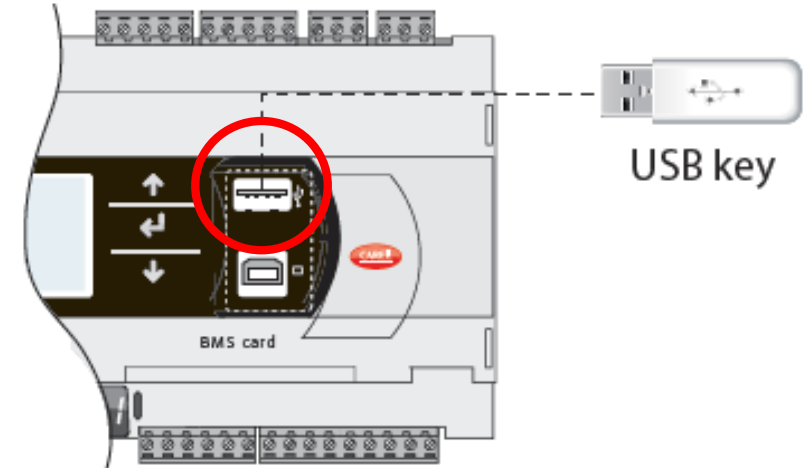

- **Always include software version in \*.dev file name**
- **If keeping backups from multiple job sites, think about how you want to name these folders**
- **ALWAYS MAKE SURE SOFTWARE VERSION (APPLICATION VERSION) AND \*.DEV FILE VERSION MATCH**

# LOOK OUT!!!

**\*\*\*If downloading from a multi-pRack setup, you MUST switch the controller off via keyboard and disconnect the pLAN connection at one end\*\*\***

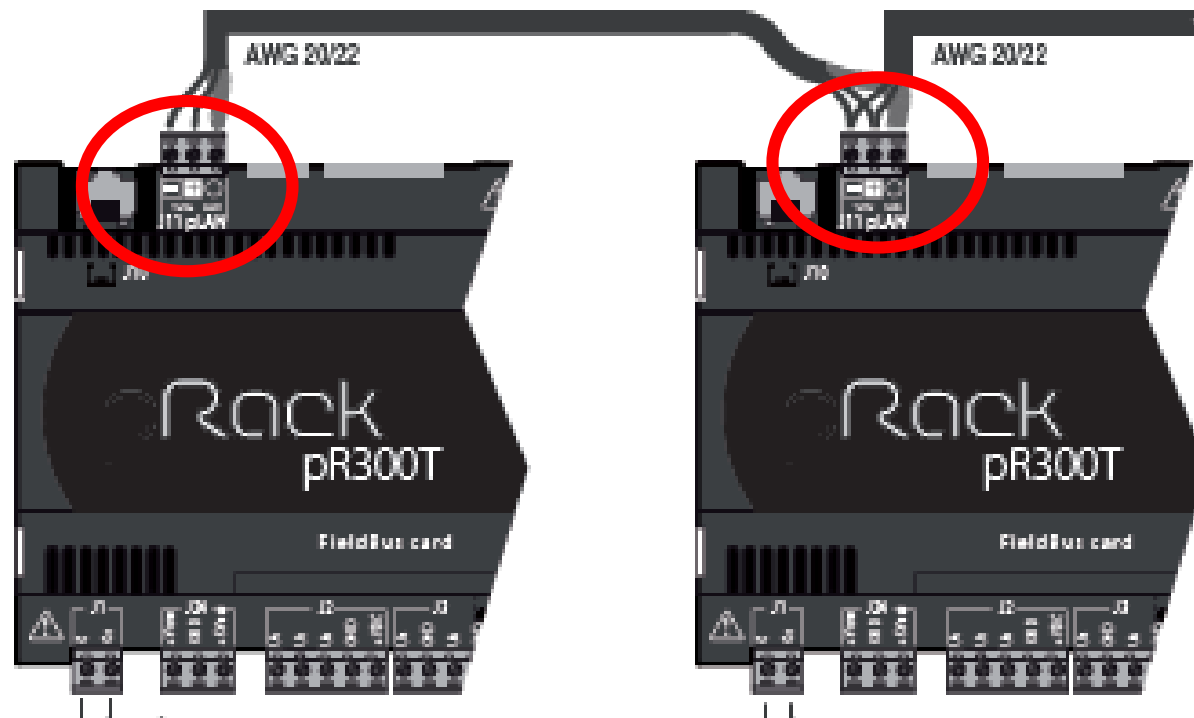

# LOOK OUT!!!



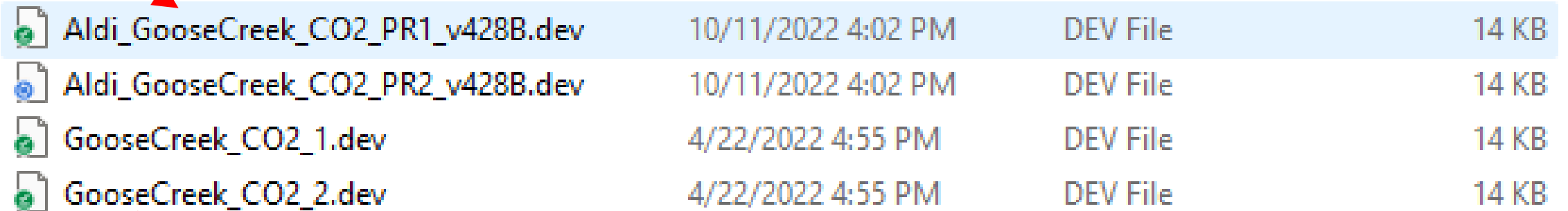

**File names....ALWAYS INCLUDE SOFTWARE VERSION!!**

This can be found in the rack controller or from the rack manufacturer

**YES!! Customer, Site, Refrigerant, Rack ID, and Software Version**



A screenshot of a file list with four entries. The first entry is highlighted in light blue. Two red arrows point to the file names: one from the 'YES!!' text above and one from the 'NOPE!!' text below.

 Aldi_GooseCreek_CO2_PR1_v428B.dev	10/11/2022 4:02 PM	DEV File	14 KB
 Aldi_GooseCreek_CO2_PR2_v428B.dev	10/11/2022 4:02 PM	DEV File	14 KB
 GooseCreek_CO2_1.dev	4/22/2022 4:55 PM	DEV File	14 KB
 GooseCreek_CO2_2.dev	4/22/2022 4:55 PM	DEV File	14 KB

**NOPE!! Not specific enough!**

# LOOK OUT!!!

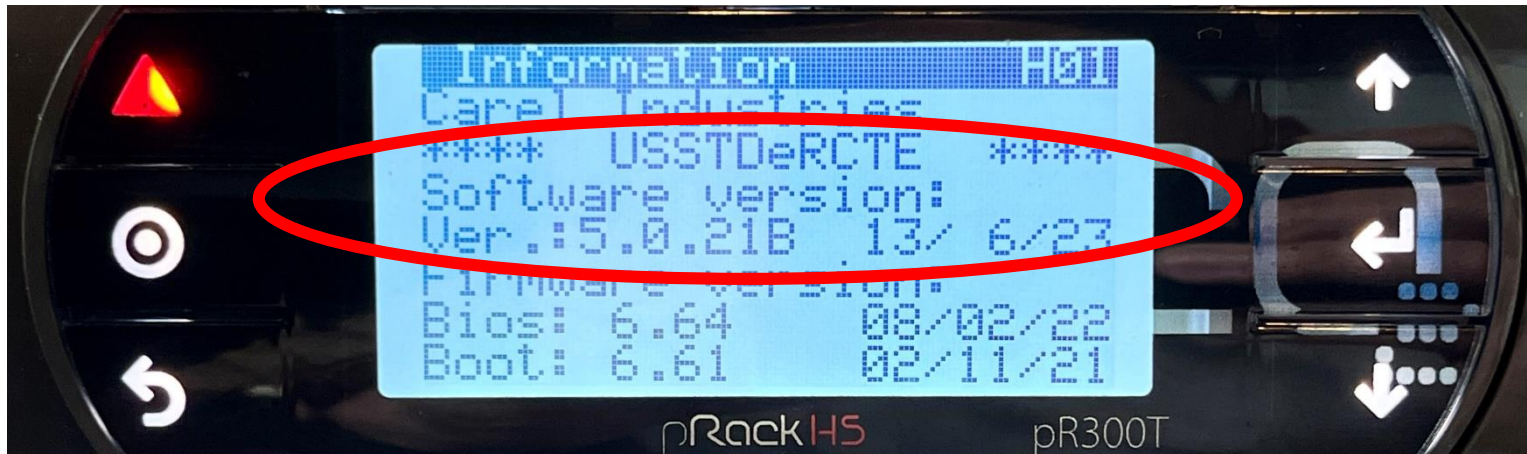

**Software  
Versions!**

# Using USB Drive

**1. Connect the USB drive to the pRack**

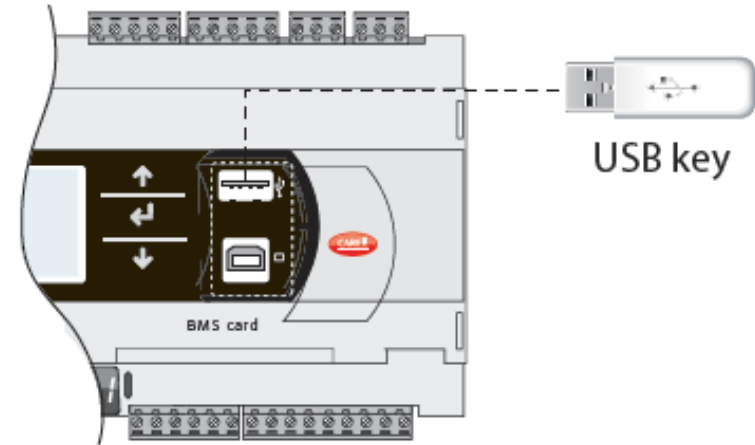

**2. Press and hold the “Alarm” and “Enter” buttons together for about 3 seconds. The system option menu will display. Use the down arrow button to scroll to “Flash/USB Memory”. Press Enter.**

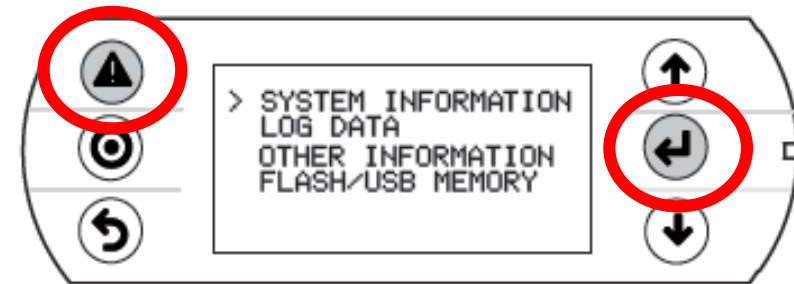

# Using USB Drive – Download – pCO to pen

## 1. Select Download

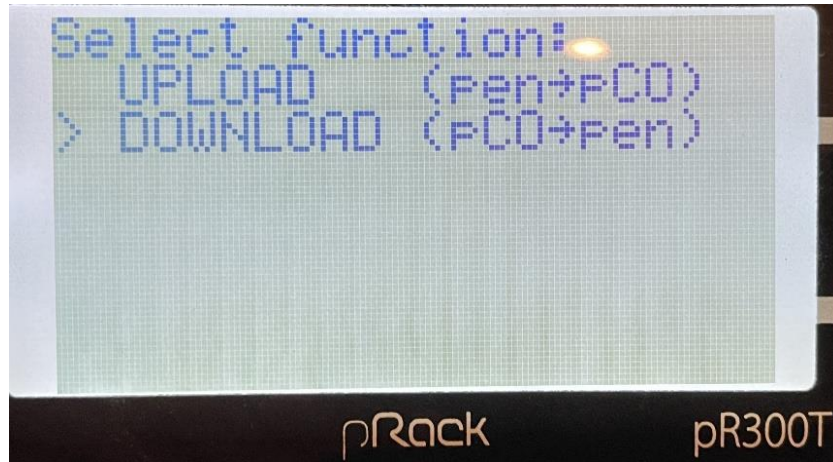

## 2. Select Download type:

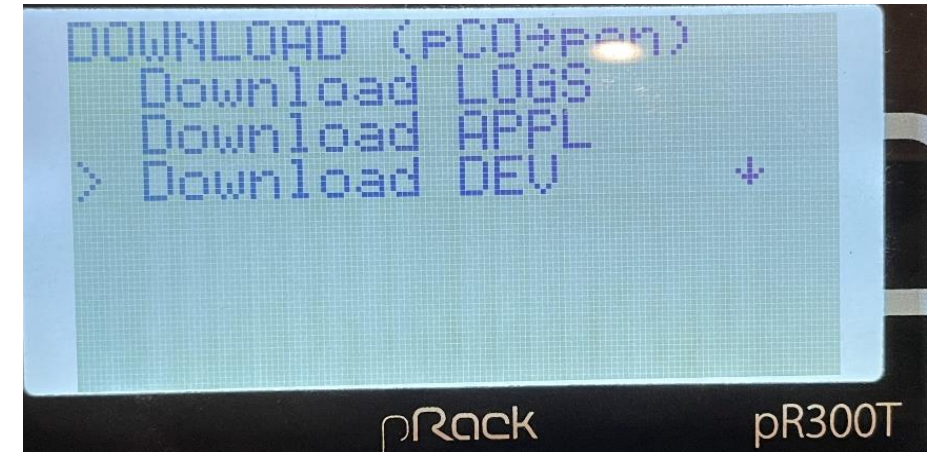

## 3. Follow screen directions





# Using USB Drive – Upload – pen to pCO

## 1. Select USB Pen Drive



## 2. Select Upload (pen -> pCO)



## 3. Select MANUAL mode



## 4. Scroll through help screen

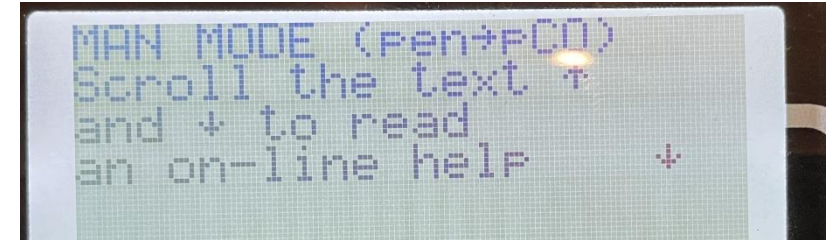

## 5. Select file or folder you want to upload by pressing enter. A "★" will appear next to the file you select. Press the PRG ("target") button



## 6. Wait and unit will reboot



# Using USB Drive - Errors

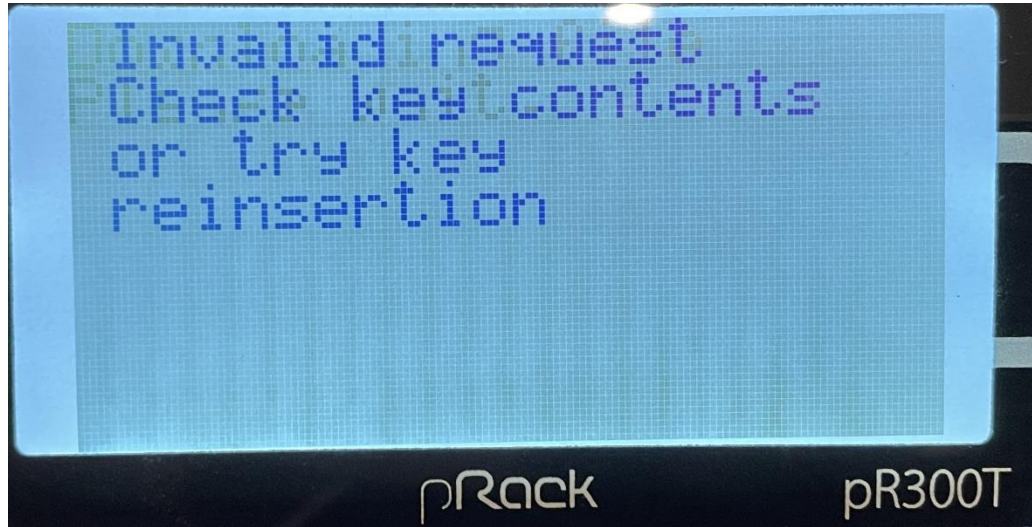

**Try another USB drive**

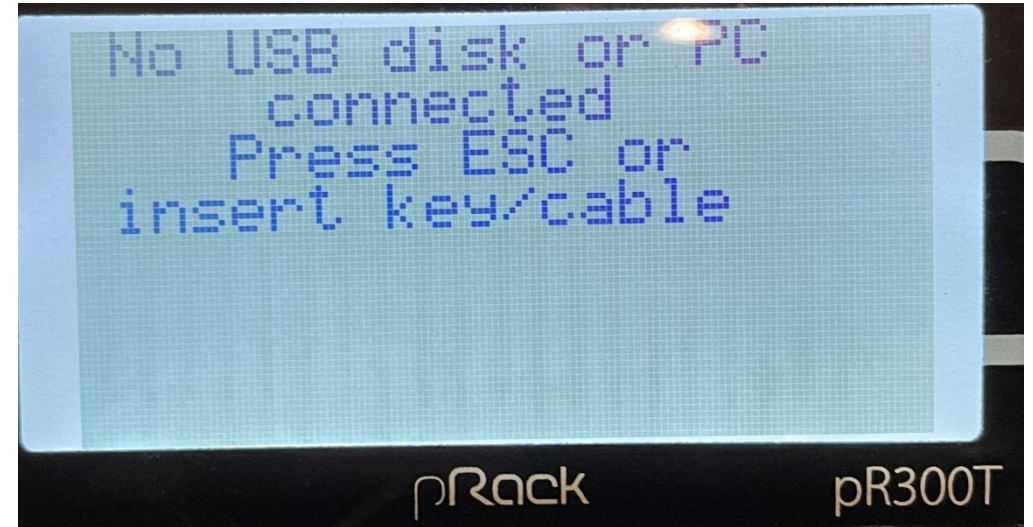

**USB drive not connected,  
reinsert, or try another USB drive**

**Other errors may mean you're trying to load a parameter file  
written for a different software version**

# Troubleshooting

# Troubleshooting

## Unstable Gas Cooler pressure

EFFECT	POSSIBLE CAUSE	SOLUTION
<b>Unstable Gas Cooler pressure</b>	Wrong configuration of HPV PID (proportional too high and integral time too low)	<ul style="list-style-type: none"><li>• Check and adjust the HPV PID (decrease the proportional and increase the integral time)</li></ul>
	Ineffective filter on the reading of ToutGC probe	<ul style="list-style-type: none"><li>• Check and adjust the filter of ToutGC</li></ul>
	Unstable HPV set point	<ul style="list-style-type: none"><li>• Check that the calculation of HPV set point is stable; otherwise keep it stable keeping stable the Gas Cooler fans</li></ul>
	Wrong placement of Gas Cooler probe	<ul style="list-style-type: none"><li>• Check that gas cooler probe has been placed in the right position (not affected by external conditions)</li></ul>

# Troubleshooting

## The Gas Cooler pressure does not reach setpoint

EFFECT	POSSIBLE CAUSE	SOLUTION
<b>The Gas Cooler pressure does not reach the set point</b>	The type of valve set is incorrect	<ul style="list-style-type: none"> <li>• Check and correct the type of valve parameter</li> </ul>
	The HPV valve is connected incorrectly (rotates in reverse)	<ul style="list-style-type: none"> <li>• Check the movement of the valve by placing it in manual control and closing or opening it completely. If the movement is reversed, check the electrical connections</li> </ul>
	Stator broken or connected incorrectly	<ul style="list-style-type: none"> <li>• (for Carel ExV only) Disconnect the stator from the valve and the cable and measure the resistance of the windings using an ordinary tester. The resistance of both should be around 36 ohms. Otherwise replace the stator.</li> <li>• Finally, check the electrical connections of the cable to the driver/ controller</li> </ul>
	Wrong configuration of PID parameter Leakage from HPV valve when it is closed	<ul style="list-style-type: none"> <li>• Check and adjust the PID parameters in order to increase the speed of the valve</li> <li>• Check that there is no transit of refrigerant through the valve when it is closed. If there is a leakage replace the valve</li> </ul>

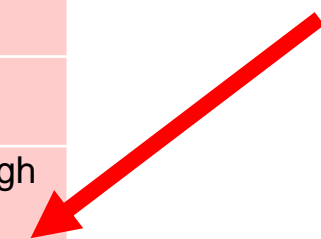
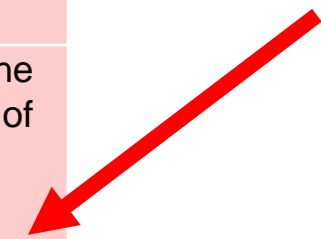

# Troubleshooting

## High CO2 Receiver pressure (1/2)

EFFECT	PROBLEM/ SCENARIO	POSSIBLE CAUSE	SOLUTION
<b>High CO2 receiver pressure (too far from the set point)</b>	According to the pRack info the RPRV valve is working properly	The type of valve set is incorrect	<ul style="list-style-type: none"> <li>Check and correct the type of valve parameter</li> </ul>
		The RPRV valve is connected incorrectly (rotates in reverse)	<ul style="list-style-type: none"> <li>Check the movement of the valve by placing it in manual control and closing or opening it completely. If the movement is reversed, check the electrical connections</li> </ul>
		Stator broken or connected incorrectly	<ul style="list-style-type: none"> <li>(for Carel ExV only) Disconnect the stator from the valve and the cable and measure the resistance of the windings using an ordinary tester. The resistance of both should be around 36 ohms. Otherwise replace the stator.</li> <li>Finally, check the electrical connections of the cable to the driver.</li> </ul>
		Driver and RPRV valve are not synchronized (the valve opening shown from the driver does not match with the real position of the valve)	<ul style="list-style-type: none"> <li>Switch off and switch on the pRack or stop and then start again the pRack regulation</li> </ul>
		Wrong sizing of the RPRV valve	<ul style="list-style-type: none"> <li>Check the RPRV valve selection</li> </ul>

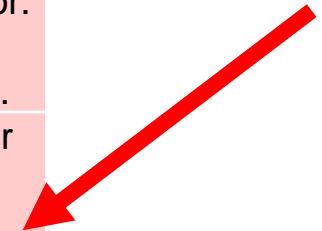

# Troubleshooting

## High CO2 Receiver pressure (2/2)

EFFECT	PROBLEM/ SCENARIO	POSSIBLE CAUSE	SOLUTION
<b>High CO2 receiver pressure (too far from the set point)</b>	According to the pRack info the RPRV valve opening is too low or it is always closed	Wrong configuration of PI parameter	<ul style="list-style-type: none"><li>• Check and adjust the PI parameters in order to increase the speed of the valve</li></ul>
		Receiver safety procedure not configured	<ul style="list-style-type: none"><li>• Check and configure the receiver safety procedure</li></ul>
		Set Point HPV too low	<ul style="list-style-type: none"><li>• Check and adjust the configuration of HPV valve in order to increase the HPV set point</li></ul>

# Troubleshooting

## Low CO2 Receiver pressure (1/2)

EFFECT	PROBLEM/ SCENARIO	POSSIBLE CAUSE	SOLUTION
<b>Low CO2 receiver pressure (too far from the set point)</b>	According to the pRack info the RPRV valve is working properly	The type of valve set is incorrect	<ul style="list-style-type: none"> <li>Check and correct the type of valve parameter</li> </ul>
		The RPRV valve is connected incorrectly (rotates in reverse)	<ul style="list-style-type: none"> <li>Check the movement of the valve by placing it in manual control and closing or opening it completely. If the movement is reversed, check the electrical connections</li> </ul>
		Stator broken or connected incorrectly	<ul style="list-style-type: none"> <li>(for Carel ExV only) Disconnect the stator from the valve and the cable and measure the resistance of the windings using an ordinary tester. The resistance of both should be around 36 ohms. Otherwise replace the stator.</li> <li>Finally, check the electrical connections of the cable to the driver.</li> </ul>
		Drive and RPRV valve are not synchronized (the valve opening shown from the driver does not match with the real position of the valve)	<ul style="list-style-type: none"> <li>Switch off and switch on the pRack or stop and then start again the pRack regulation</li> </ul>
		Wrong sizing of the RPRV valve	<ul style="list-style-type: none"> <li>Check the RPRV valve selection</li> </ul>
		Leakage from RPRV valve when it is closed	<ul style="list-style-type: none"> <li>Check that there is no transit of refrigerant through the valve when it is closed. If there is a leakage replace the valve</li> </ul>



# Troubleshooting

## Low CO2 Receiver pressure (2/2)

EFFECT	PROBLEM/ SCENARIO	POSSIBLE CAUSE	SOLUTION
<b>Low CO2 receiver pressure (too far from the set point)</b>	According to the pRack info the RPRV valve opening is too High	Wrong configuration of PI parameter	<ul style="list-style-type: none"> <li>Check and adjust the PI parameters in order to increase the speed of the valve</li> </ul>
		Receiver safety procedure not configured	<ul style="list-style-type: none"> <li>Check and configure the receiver safety procedure</li> </ul>
		Set Point HPV too High	<ul style="list-style-type: none"> <li>Check and adjust the configuration of HPV valve in order to reduce the HPV working set point</li> <li>If it happens during the commissioning, it is possible to decrease temporarily the P<sub>critic</sub> of transcritical zone or increase the min opening HPV during on</li> </ul>
		Insufficient refrigerant	<ul style="list-style-type: none"> <li>Check that there is enough refrigerant inside the circuit; otherwise charge the circuit</li> </ul>

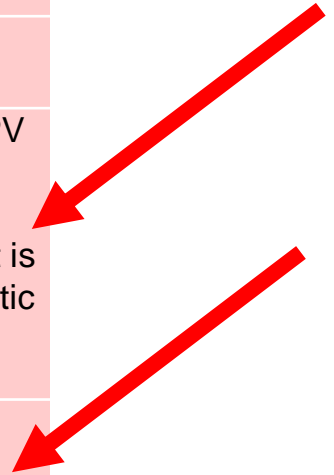

Reference

# Regulation Proportional + Integral

*kp: proportional gain → is inversely proportional to the Regulation Differential*

$$\text{Pressure} \\ k_p = \frac{100}{2 \cdot \text{Diff}} \left[ \frac{\%}{\text{barg}} \right]$$

$$\text{Temperature} \\ k_p = \frac{100}{2 \cdot \text{Diff}} \left[ \frac{\%}{^\circ\text{C}} \right]$$

Depending on the regulation variable, **kp** is the request percentage variation for every variation of **1 barg** or **°C**

## For example:

- **Diff = 1 barg**

*For a pressure change of 1 barg, a power request change of **50%** for proportional factor*

**Low Differential → system fast and reactive, possible instability**

- **Diff = 10 barg**

*For a pressure change of 1 barg, a power request change of **5%** for proportional factor*

**High Differential → system slow and not very reactive**

# Regulation Proportional + Integral

**Ti: integral time:** the time of integration needed to bring back the regulation variable to the setpoint

For example:

Setpoint = 1 barg

Actual Pressure = 2 barg

$$\text{Integral\_action} = \frac{k_p \cdot (\text{SetP} - \text{Actual pressure})}{T_i} \left[ \frac{\%}{\text{sec}} \right]$$

## Case 1:

- Diff = 5 barg → Kp = 10%
- Ti = 10 sec → Power request will increase **1% every second until setpoint is reached**

## Case 2:

- Diff = 5 barg → Kp = 10%
- Ti = 40 sec → Power request will increase **0.25% every second until setpoint is reached**

**high Ti → system slow to reply to system instability**

**low Differential → system fast and reactive, possible instability**

# pR300T: Line 1 – Optimal pressure

## Transcritical zone: line 1

$$T_{GC} > T_{12}$$

Optimal pressure is calculated as a function of ToutGC.

- Manual config: point B pressure and line slope (Coeff.1) are set manually

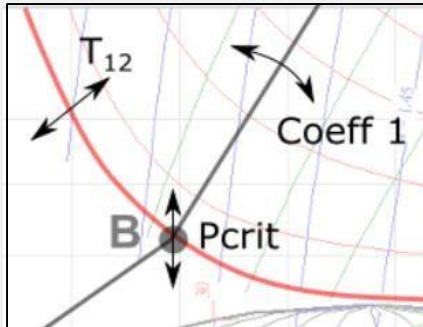

$$P_{line1} : coeff1 * (T_{gc} - T_{12}) + P_{critic}$$

Default settings are:

- coeff1=2.5
- T12=31°C
- Pcritic=82 barg

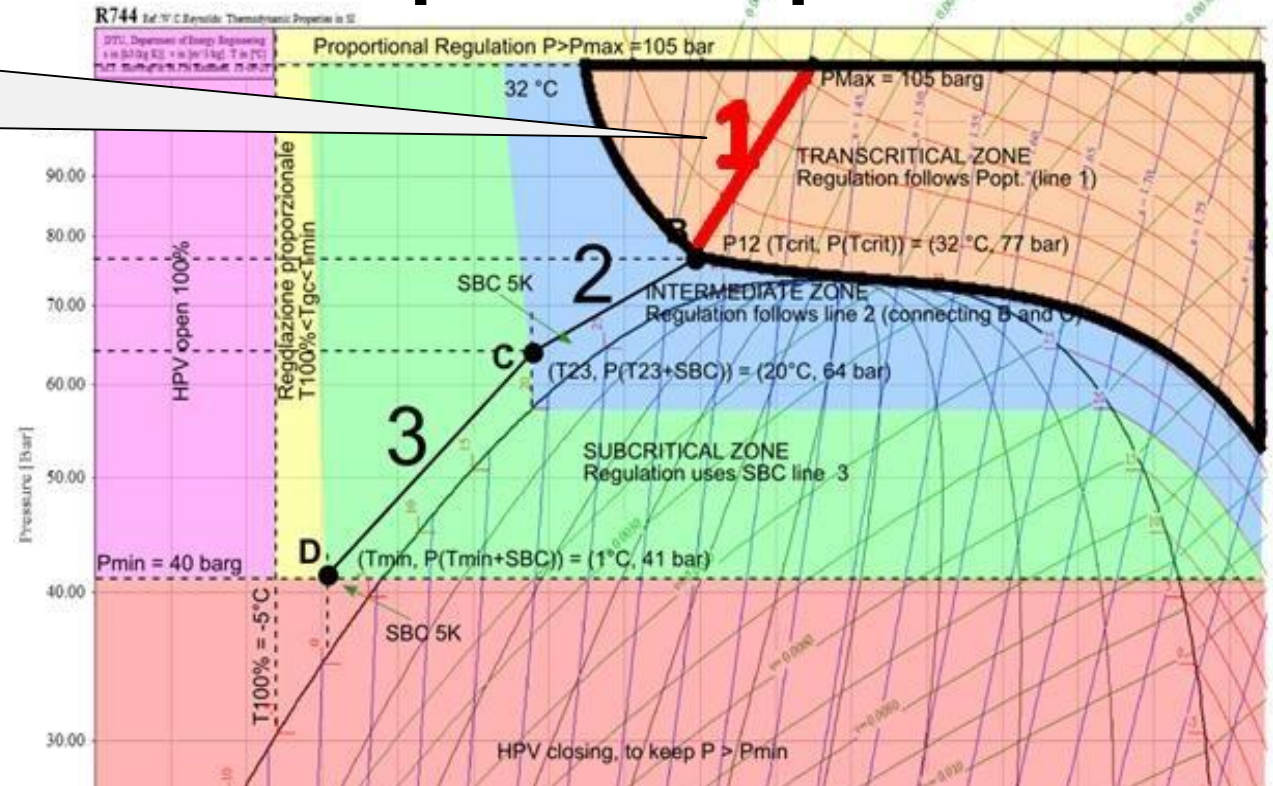

```

Trans.Settings E1b05
Graph design
P100%: 109.0barg
Pmax: 104.0barg
Pcritic: 82.0barg
T12: 31.0°C
T23: 20.0°C
Tmin: 6.0°C
    
```

```

Trans.Settings E1b06
Graph design
T100%: -10.0°C
Delta: 3.0°C
Lines design
Coeff.1: 2.5
    
```



# pR300T: Line 3 - Subcritical

## Subcritical zone: line 3

$$T_{outGC} < T_{23}$$

Optimal pressure is calculated to follow the saturation curve with a user defined delta (SBC)

$$P_{line3} : P_{sat}(T_x + \delta)$$

Default settings are:

- Below  $T_{23} = 20^{\circ}\text{C}$
- Delta =  $3,0^{\circ}\text{C}$
- Above  $T_{min} = 6,0$

## Lower proportional zone:

$$T_{100\%} < T_{GC} < T_{min}$$

The valve is opened with a proportional regulation. The valve will not reduce opening until  $T_{GC} > T_{min}$

```

Trans.Settings Eib05
Graph designn
P100%: 109.0barg
Pmax: 104.0barg
Pcritic: 82.0barg
T12: 32.0°C
T23: 20.0°C
Tmin: 6.0°C
    
```

```

Trans.Settings Eib06
Graph designn
T100%: -10.0°C
Delta: 3.0°C
Lines designn
Coeff.1: 2.5
    
```

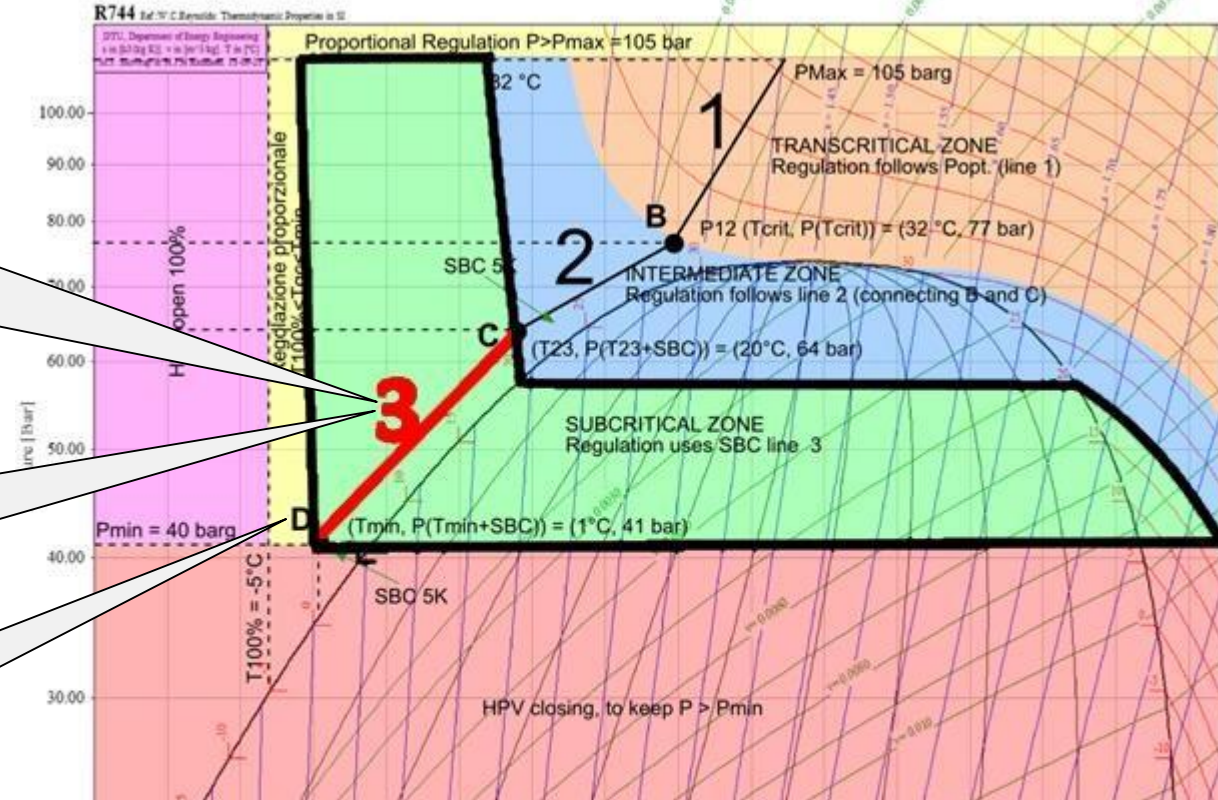

# pR300T: Line 2 - Intermediate

## Upper proportional zone:

$P_{max} < P_{GC} < P_{100\%}$   
 The valve is opened with a proportional regulation. When  $HP = P_{100\%}$ , the valve will be fully opened.  
 The valve will not reduce opening until  $HP < P_{max}$

## Intermediate zone: line 2

$T_{23} \leq T_{GC} \leq T_{12}$   
 Optimal P is calculated on a line connecting point B and C

$$P_{line2} : [(P_{sat}(T_{23} + \delta) - P_{critic}) / (T_{23} - T_{12})] * (T_x - T_{12}) + P_{critic}$$
 Default settings are:

- $T_{23} = 20^{\circ}C$
- $T_{12} = 31^{\circ}C$
- $\Delta = 3,0^{\circ}C$

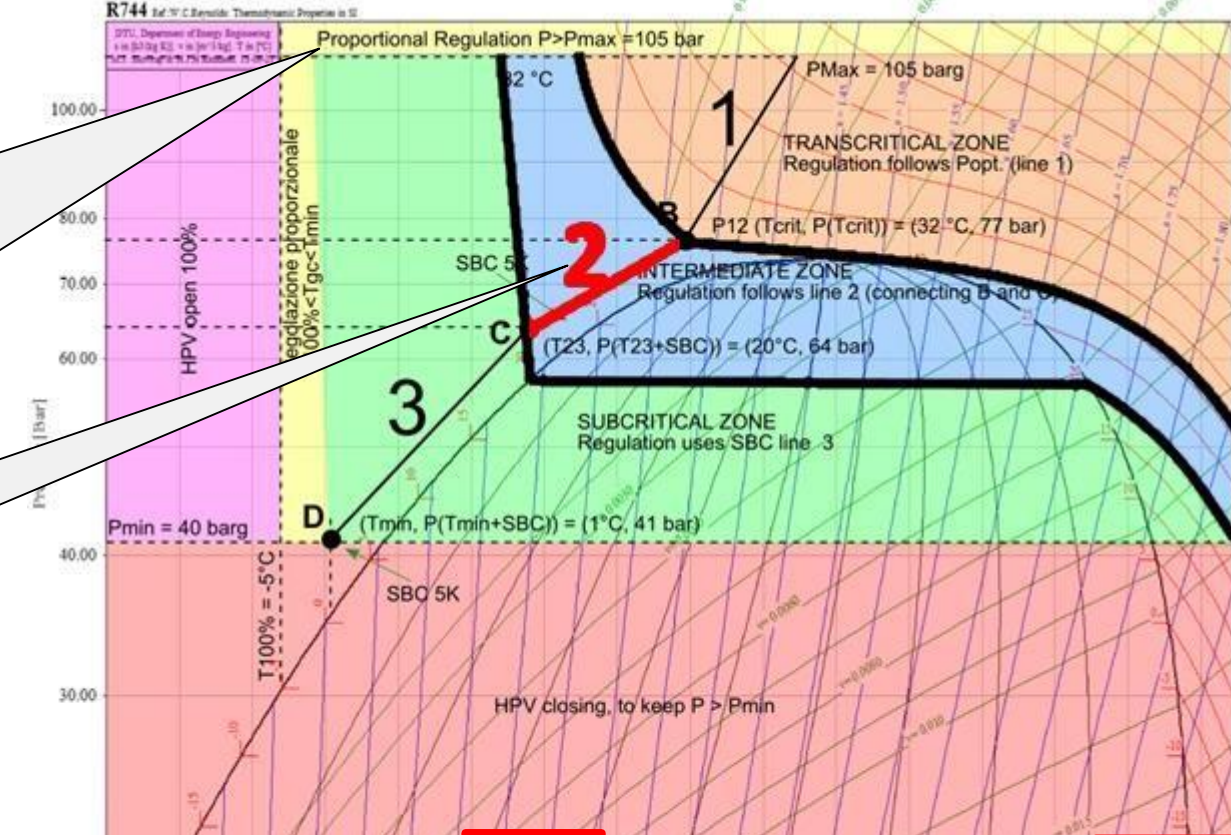

```

Trans.Settings Eib05
Graph designn
P100%: 109.0barg
Pmax: 104.0barg
Pcritic: 82.0barg
T12: 31.0°C
T23: 20.0°C
Tmin: 6.0°C
  
```

```

Trans.Settings Eib06
Graph designn
T100%: -10.0°C
Delta: 3.0°C
Lines designn
Coeff.1: 2.5
  
```





Visit

[natref.carel.com](http://natref.carel.com)



# Share Your Feedback!



**To receive an electronic training certificate:**

1. Scan or visit [nasrc.org/session-surveys](https://nasrc.org/session-surveys)
2. Provide your name and email at the end of the survey

***Please Note:** You will not receive a certificate unless you share your name on the survey form.*

## Introduction to CAREL CO2 Rack Control

**Chris Butler**  
**CAREL**